



Mounted Bearings, HubFlex™ Couplings, Farm Products and Shaft Mount Reducers

A Regal Brand

REGAL

What's Inside...

Section N

DuraLine®
Mounted Bearings

Over 300 NEW items

*A competitive alternative
without sacrificing reliability*



Section M

IndustriaLine™
Mounted Bearings

Over 200 NEW items

*Premium performance
for rigorous applications*



Section O

CleanLine™ Plus
and CleanLine™ UltraPlus™

50 NEW items

*Ultimate pharmaceutical, food,
meat processing and
washdown solutions*



Section P

NEW

ModuLine™
Spherical Roller
Bearings

*A modular design
mounted bearing to
handle the loads of
demanding applications*



Section Q

HubFlex™
Flexible Shaft
Couplings

NEW

*Easy installation,
low maintenance,
minimal downtime*



Section R

Farm Products
and Accessories

*Hubs, shafts, couplings,
PTO adapters and more,
for applications on the
farm and beyond*



Section G

PowerTorque® Shaft
Mount Reducers

*Rock solid dependability for
the toughest applications in
the industry*



At The Heart Of What Drives Your World...

Since 1892, HUB CITY has a reputation for producing tough, dependable driveline components for industry and agriculture worldwide. As a world-class manufacturer, HUB CITY provides the technology, expertise and support to perfectly integrate our products into your application. Whether your application requires a standard, modified standard or custom product, HUB CITY will always be at the heart of what drives your world.



A multi-pallet machining center machines precisely and efficiently.

Leading Edge Engineering Team Brings You:

- Application engineers that provide advanced product designs and support to meet your exact requirements
- Advanced product design for diverse applications
- Custom designed prototypes for evaluation and testing
- Support from inception to completion of the product design through manufacturing

State-of-the-Art Manufacturing with Capabilities Including:

- Extensive computer numerically controlled (CNC) machines for milling, turning, drilling, boring, threading, grinding, hobbing and gear cutting of barstock, forgings and castings
- Equipment supported by Direct Numerical Control (DNC), Computer-Aided Design and Manufacturing (CAD/CAM), and computer-based systems for Enterprise Resource Planning (ERP)
- Microprocessor-controlled heat treating that carburizes and hardens, through-hardens, induction hardens, or tempers and anneals a variety of materials



State-of-the-art testing equipment and comprehensive product testing ensures quality.

World-Class Quality is Assured By:

- Design simplicity and structural integrity
- Comprehensive systems, procedures and work instructions in accordance with ISO-9000 standards
- State-of-the-art testing equipment and laboratory

Dedicated Customer Service Means Support From:

- Two manufacturing facilities in South Dakota
- Eight Assembly/Distribution Centers conveniently located throughout North America
- Skilled customer service professionals committed to excellence in providing product information and prompt order processing



Hub City is proud to announce enhanced performance and improved lead times as a result of ongoing implementation of Lean Six Sigma Initiatives.



Many of our most sought after products are now available in 3 days or less!

Hub City

Standard Products

Worms, Bevels, Parallels and Shaft Mount Reducers

Most items available in 3 days or less!



- Worm Gear Drives
Over 250 Standard Models
- Spartan Aluminum Drives
Modular Design Flexibility
- Bevel Gear Drives
Universal Mounting
- PowerTorque™
Ten Competitively Sized Models
- Parallel Shaft Drives
Hydraulic, Electric or Shaft Input

- Ratios 5/1 to 216,000/1
0.183 thru 100 HP
- Ratios 5/1 to 2,220/1
0.183 thru 7.5 HP
- Ratios 1/1 to 7.33/1
0.016 thru 1,250 HP
- Ratios 9/1, 15/1 and 25/1
0.25 thru 200 HP
- Ratios 1/1 to 70/1
2 thru 530 HP

High Efficiency



Most items available in 3 - 5 days!

- HERA™ - High Efficiency Right Angle
Worm Gear Drive Replacement
- Helical Inline Drives
Competitively Sized and Rated
- Helical Bevel Drives
High Capacity Gearing
- Helical Worm Drives
Universal Mounting Dimensions
- Compact Helical Parallel
Four Popular Models

- Ratios 7.8/1 to 58.92/1
0.74 thru 27.3 HP
- Ratios 2.25/1 to 3,334/1
0.14 thru 125 HP
- Ratios 6.5/1 to 3,413/1
0.25 thru 130 HP
- Ratios 6/1 to 3,460/1
0.25 thru 23 HP
- Ratios 3.42/1 to 3,377/1
0.25 thru 20 HP

Cleanline™, Hub³ and Washdown

Most items available in 5 to 7 days!



- Hub³ Stainless Steel Worm Gear Drives, Bevel Gear Drives, Helical Inline and Helical Bevel
Smooth Exterior Surfaces
High Pressure Seals
316 SS Housing & Shafts

- Ratios 1/1 to 138/1
0.25 thru 50 HP

- CleanLine Plus™ Composite and CleanLine UltraPlus™ Stainless Steel Mounted Bearings
Smooth Exterior Surfaces
Corrosion Resistant Materials

- Pillow Block & Flange
Bore Sizes to 1-15/16"

Mounted Bearings



Most items available in 3 days or less!

- IndustriaLine™ Mounted Bearing
Ball Bearing Pillow Blocks, Flange Blocks & Take-Up Units
Setscrew & Eccentric Locking
- DuraLine™ Mounted Bearings
Popular Sizes of Ball Bearing Pillow Blocks & Flange Blocks
Economical Durability
- ModuLine™ Spherical Roller
Modular Design mounted bearing handles demanding load applications

- Bore Sizes Range
1/2" thru 3-1/2"

- Bore Sizes Range
1/2" thru 3-1/2"

- Bore Sizes Range
1-7/16" thru 4-15/16"

Motors, Farm Products and Accessories



- Electric Motors
Single or Three Phase

- Sizes Range
1/4 thru 30 HP

- Farm Products & Accessories
Couplings, PTO Adapters
Splined Shafts

- Capacity Range
thru 125 HP

Hub City Custom Products

HUB CITY provides technically advanced products to meet your custom application. Our engineering team offers complete support from design and prototypes to the manufactured unit.

HUB CITY Custom Products Are Unlimited:

Outdoor Power Equipment

- Used to power hand-held outdoor equipment such as: rubber paddle brooms, nylon bristle brushes & cultivator attachments

Food Processing Machinery

- Powers beverage and bottling equipment
- Drives fruit and vegetable processors
- Used in meat and poultry processing plants
- Operates vibratory conveyors for the confectionary and baking industries

Military Applications

- Used in military rocket launchers. It raises and lowers the canister, which contains the rockets, positioning them for firing.
- 1:1 spiral bevel gearing & 1.53:1 spiral bevel gearing
- Special paint & corrosion protection applied to all exposed surfaces

Boom Rotation Drives

- Used for rotating the main boom in small utility and electrical maintenance vehicles
- Spur gear mates with internal or external gear teeth, which are part of the main rotation bearing
- Manufactured in several sizes and output flange configurations

Packaging Equipment

- Suitable for production equipment and food processing
- Increases production in packaging machinery: shrink wrap & snack bagging applications, which crimp, seal and cut snack bags
- Manufactured with planetary gearing

Spraying Equipment

- Operates spray pumps in recreational and commercial vehicles. The spray pumps are run by the low speed output shaft, and the double extended high speed input shaft transmits power to the vehicle differential.
- Utilizes our standard Model 180, 5:1, gear design in a special housing

Monorail Drive

- Used in monorail and bottling conveyor application
- Ratios: 19.63:1 to 78.52:1
- Manufactured with or without disengage mechanisms

Utility Truck Applications

- Used for operating air compressors, pumps, generators, etc.
- Manufactured in sizes specific to application

Concrete Grinding and Finishing Equipment

- Powers the finishing tools for creating desired surface texture



Hub City

Table of Contents

	Product	Description	Size Range	Section
	IndustriaLine™ Mounted Bearings	<ul style="list-style-type: none"> • Ball Bearing Pillow Blocks, Flange Blocks & Take-Up Units • Narrow & Wide Inner Race 	Shaft Diameters 1/2" thru 3-12"	M
	DuraLine® Mounted Bearings	<ul style="list-style-type: none"> • Ball Bearing Pillow Blocks and Flange Blocks • Setscrew & Eccentric Locking • Narrow & Wide Inner Race 	Shaft Diameters 1/2" thru 3-12	N
	CleanLine™ Washdown Pharmaceutical and Food Processing Solutions	<ul style="list-style-type: none"> • CleanLine UltraPlus Stainless Steel Mounted Bearings • CleanLine Plus Thermoplastic Composite Bearings 	Shaft Diameters 1/2" thru 1-15/16"	O
	ModuLine™ Spherical Roller Bearings	<ul style="list-style-type: none"> • Spherical Roller Pillow Blocks & Flange Blocks • Cast Steel Housings 	Shaft Diameters 1-7/16" thru 4-15/16"	P
	Hub Flex™ Flexible Shaft Couplings	<ul style="list-style-type: none"> • Hubs, Inserts & Covers • Easy Installation • Carbon Steel & Stainless Steel Hubs & Covers • Urethane Inserts in 5 types for various applications 	Shaft Diameters 1/2" thru 4"	Q
	Farm Products and Accessories	<ul style="list-style-type: none"> • Over-Running Couplers • Splined Couplings • Splined Shafts • P.T.O. Drives & Adaptors 	Up to 125 HP	R
	PowerTorque™ Shaft Mount Reducers	<ul style="list-style-type: none"> • Precision Hardened and Ground Gearing • Ductile Iron Housing • Screw Conveyor Adaptors • Competitive Interchangeability 	9:1 thru 25:1 Ratios .25 thru 200HP	G
Warnings and Cautions Lubrication and Installation Instructions General Engineering				S
Terms and Conditions Model Index				T

Hub City IndustriaLine™ Bearing Units

Mounted Bearing Features Index	M-1
Features Index.....	M-4
Engineering and Selection — Ball Bearing Units	M-6
NEW - HVAC Air Handling Bearings.....	M-8
100 Series Pillow Blocks.....	M-10
100 Series Flange Blocks	M-11
100 & 200 Series Load Ratings	M-14
200 Series Pillow Blocks.....	M-15
200 Series Flange Blocks	M-23
200 Series Flange Brackets & Flange Cartridges....	M-27
200 Series Take Up Units.....	M-28
Take-Up Frames — Ball Bearing Units	M-32
Ball Bearing Inserts	M-35
350 Series Load Ratings	M-37
350 Series Bearings	M-38
Interchange Comparisons — Ball Bearing Units.....	M-42

Over 200 NEW items in this section!

**For Stainless Steel
& Thermoplastic
Composite Bearings,
See Section O**

DOWNLOAD AVAILABLE CAD MODELS AT: WWW.HUBCITYINC.COM
Certified prints are available upon request

EMAIL: hubsales@regalbeloit.com • www.hubcityinc.com



Hub City IndustriaLine™ Bearing Units

Hub City offers a wide range of products in the IndustriaLine™ mounted ball bearing product line. These include pillow blocks, 2, 3 and 4 hole flange blocks, 4 hole piloted flange cartridges, and wide slot and narrow slot take-up units. Ball bearing units are available with

setscrew locking or eccentric locking collar, with narrow inner race or wide inner race, with normal duty or medium duty bearings. Housings are available in gray cast iron or Hub-Alloy®. Refer to Features Index for description of specific units.

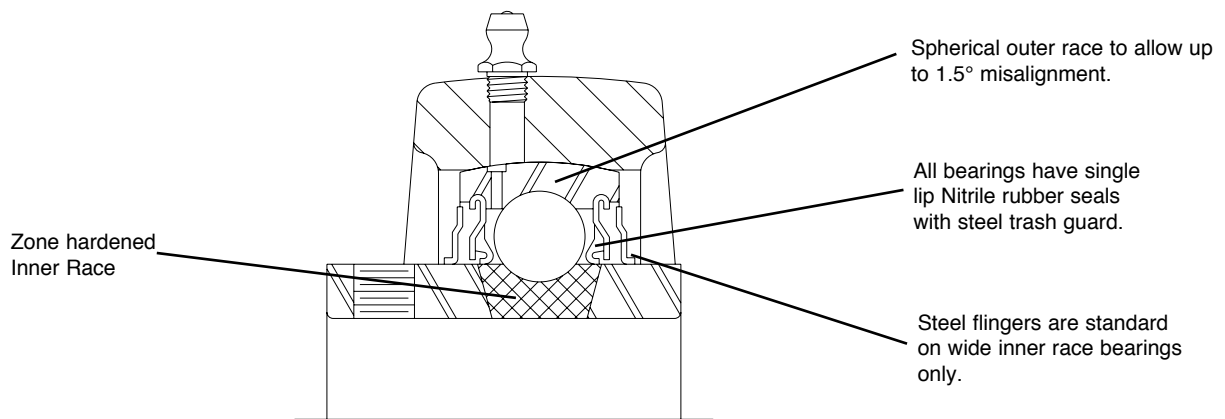
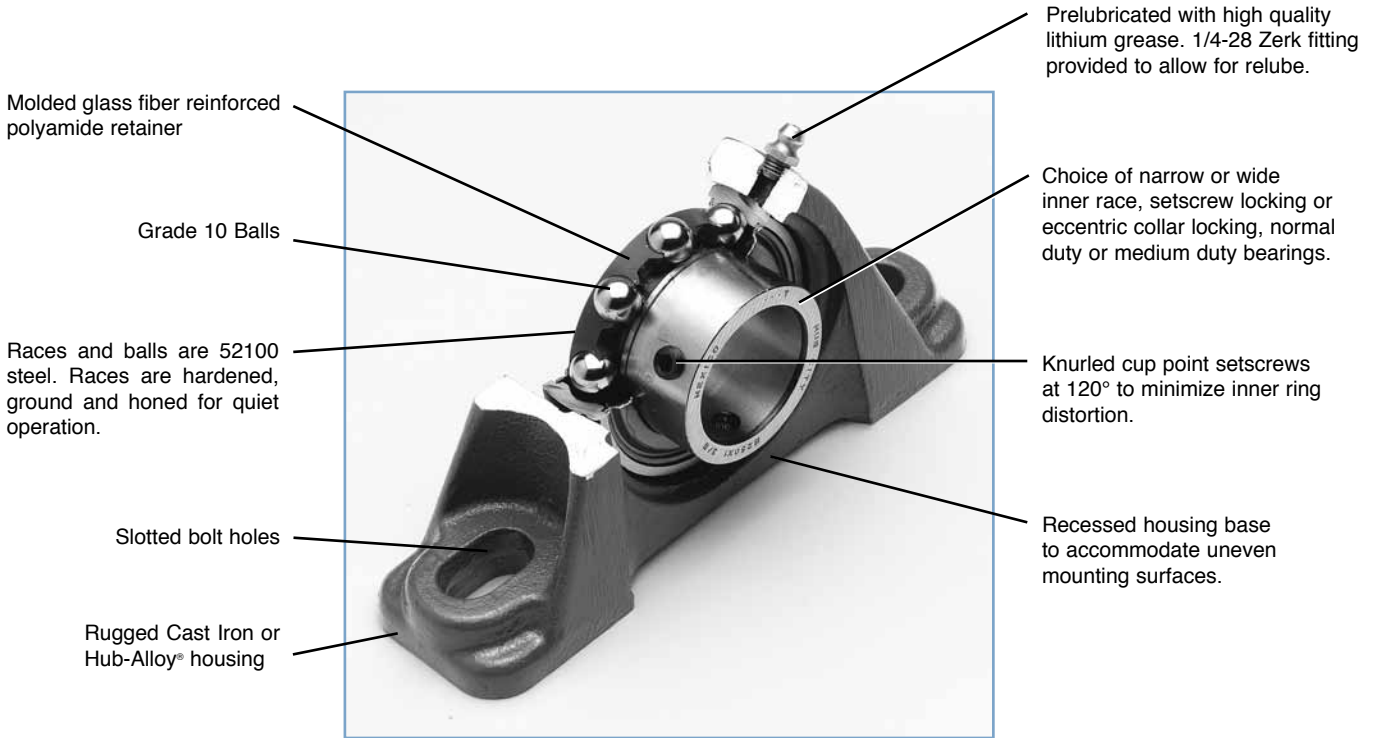

Typical Cross Section

(Continued on next page)

DOWNLOAD AVAILABLE CAD MODELS AT: WWW.HUBCITYINC.COM

Certified prints are available upon request

CALL: (605) 225-0360 • FAX: (605) 225-0567

Hub City IndustriaLine™ Bearing Units

Features

Bearings

Bearings have spherical outer races to accommodate up to 1.5° misalignment. Races and balls are made of SAE 52100 vacuum degassed bearing quality steel. Ball retainers are made of molded, glass fiber reinforced polyamide. Races are hardened, ground and honed for quiet operation, and Grade 10 balls are used. Inner races are zone hardened in the ball raceway and seal contact areas. The setscrew end is unhardened to prevent cracking at the setscrew threads. Setscrews are located at 120° to minimize inner ring distortion, and have knurled cup point to resist loosening under vibration. Seals have a nitrile rubber lip bonded to a steel trash

guard.. The positive contact, low friction seal rides on the precision ground surface of the inner race. Wide inner race bearings also have steel flingers that rotate with the inner race to provide extra protection. All ball bearings are prelubricated with high quality lithium grease. Hub City bearings have an operating temperature range of -25° F to 225° F.

Housing

Housings for Hub City bearing units are precision machined from rugged cast iron or high strength Hub-Alloy® castings.

Hub-Alloy® is a cast ferrous material this is manufactured in a carefully controlled process to produce properties exceeding the specifications listed below. Hub-Alloy® can be used to replace malleable iron or ductile iron. It is recommended for severe applications where the stronger material is required to withstand heavy loads imposed on the housing. Hub-Alloy® has tensile strength properties in the range 50-65,000 psi, yield strength in the range 32-45,000 psi, and elongation in the range 10-12%. Specific properties of particular housings vary according to the configuration of the housing.

Cast iron housings meet or exceed the requirements of SAE G3000 gray iron. Typical tensile strength is 30,000 psi.

Special Modifications

Hub City can furnish modified or special units to suit customer requirements. Typical modifications include:

- Housing modifications
- Special grease types
- Dust caps
- Auxiliary anti-rotation devices
- Custom bearing units with special housings and/or bearings

Modified or special units may be subject to increased lead time and minimum production order quantities.

Hub City IndustrialLine™ Bearing Units

Features Index



Ball Bearing Pillow Blocks

SERIES	RATING TABLES	OUTLINE DIMENSIONS	SHAFT LOCKING	BEARING LUBRICATION	BACKING HEIGHT	HOUSING MATERIAL	SIZE RANGE	INTERCHANGE REFERENCE
PB120	Page M-14	Page M-10	Eccentric Collar	Relube	High	HUB-ALLOY®	1/2 - 1-7/16	Page M-42
PB150	Page M-14	Page M-10	Setscrew	Relube	High	HUB-ALLOY®	1/2 - 1-7/16	Page M-42
PB220	Page M-14	Page M-15	Eccentric Collar	Relube	Low	Cast Iron	1/2 - 2-7/16	Page M-43
PB221	Page M-14	Page M-15	Eccentric Collar	Relube	High	Cast Iron	1/2 - 2-7/16	Page M-43
PB220W	Page M-14	Page M-16	Eccentric Collar	Relube	Low	Cast Iron	3/4 - 2-7/16	Page M-43
PB221W	Page M-14	Page M-16	Eccentric Collar	Relube	High	Cast Iron	3/4 - 2-7/16	Page M-43
PB220HW	Page M-14	Page M-17	Eccentric Collar	Relube	Low	HUB-ALLOY®	3/4 - 2-7/16	Page M-43
PB221HW	Page M-14	Page M-17	Eccentric Collar	Relube	High	HUB-ALLOY®	3/4 - 2-7/16	Page M-43
PB250	Page M-14	Page M-18	Setscrew	Relube	Low	Cast Iron	1/2 - 2-15/16	Page M-43
PB251	Page M-14	Page M-18	Setscrew	Relube	High	Cast Iron	1/2 - 2-15/16	Page M-43
PB250W	Page M-14	Page M-19	Setscrew	Relube	Low	Cast Iron	5/8 - 2-7/16	Page M-43
PB251W	Page M-14	Page M-19	Setscrew	Relube	High	Cast Iron	5/8 - 2-7/16	Page M-43
PB250HW	Page M-14	Page M-20	Setscrew	Relube	Low	HUB-ALLOY®	5/8 - 2-7/16	Page M-43
PB251HW	Page M-14	Page M-20	Setscrew	Relube	High	HUB-ALLOY®	5/8 - 2-7/16	Page M-43
PB281WAH	Page M-14	Page M-8	Concentric	Relube	High	Cast Iron	3/4 - 2-7/16	
TPB220	Page M-14	Page M-21	EccLock	Relube	Tapped Base	Cast Iron	1/2 - 2-3/16	Page M-42
TPB220W	Page M-14	Page M-21	EccLock	Relube	Tapped Base	Cast Iron	5/8 - 2-3/16	Page M-42
TPB250	Page M-14	Page M-22	Setscrew	Relube	Tapped Base	Cast Iron	1/2 - 2-3/16	Page M-42
TPB250W	Page M-14	Page M-22	Setscrew	Relube	Tapped Base	Cast Iron	5/8 - 2-3/16	Page M-42
PB350	Page M-37	Page M-38	Setscrew	Relube	High	Cast Iron	1 - 3-1/2	Page M-45
PB350H	Page M-37	Page M-39	Setscrew	Relube	High	HUB-ALLOY®	1 - 3-1/2	Page M-45

DOWNLOAD AVAILABLE CAD MODELS AT: WWW.HUBCITYINC.COM

Certified prints are available upon request

CALL: (605) 225-0360 • FAX: (605) 225-0567

Hub City IndustrialLine™ Bearing Units

Features Index



Ball Bearing Flange Blocks & Flange Cartridges

SERIES	RATING TABLES	OUTLINE DIMENSIONS	SHAFT LOCKING	BEARING LUBRICATION	FLANGE STYLE	HOUSING MATERIAL	SHAFT SIZE RANGE	INTERCHANGE REFERENCE
FB110	Page M-14	Page M-11	Setscrew	Non-Relube	2-Hole	HUB-ALLOY®	1/2 - 1-7/16	Page M-42
FB120	Page M-14	Page M-12	Eccentric Collar	Relube	3-Hole	HUB-ALLOY®	1/2 - 1-7/16	Page M-42
FB130	Page M-14	Page M-12	Eccentric Collar	Relube	2-Hole	HUB-ALLOY®	1/2 - 1-7/16	Page M-42
FB150	Page M-14	Page M-13	Setscrew	Relube	3-Hole	HUB-ALLOY®	1/2 - 1-7/16	Page M-42
FB 160	Page M-14	Page M-13	Setscrew	Relube	2-Hole	HUB-ALLOY®	1/2 - 1-7/16	Page M-42
FB220	Page M-14	Page M-23	Eccentric Collar	Relube	4-Hole	Cast Iron	1/2 - 2-7/16	Page M-44
FB220HW	Page M-14	Page M-24	Eccentric Collar	Relube	4-Hole	HUB-ALLOY®	3/4 - 2-7/16	Page M-44
FB230	Page M-14	Page M-23	Eccentric Collar	Relube	2-Hole	Cast Iron	1/2 - 2-3/16	Page M-44
FB230HW	Page M-14	Page M-24	Eccentric Collar	Relube	2-Hole	HUB-ALLOY®	3/4 - 2-7/16	Page M-44
FB250	Page M-14	Page M-25	Setscrew	Relube	4-Hole	Cast Iron	1/2 - 2-15/16	Page M-44
FB250HW	Page M-14	Page M-26	Setscrew	Relube	4-Hole	HUB-ALLOY®	5/8 - 2-7/16	Page M-44
FB260	Page M-14	Page M-25	Setscrew	Relube	2-Hole	Cast Iron	1/2 - 2-3/16	Page M-44
FB260HW	Page M-14	Page M-26	Setscrew	Relube	2-Hole	HUB-ALLOY®	5/8 - 2-7/16	Page M-44
FB280HWAH	Page M-14	Page M-8	Concentric	Relube	4-Hole	HUB-ALLOY®	3/4 - 2-7/16	-
FB290HWAH	Page M-14	Page M-9	Concentric	Relube	2-Hole	HUB-ALLOY®	3/4 - 2-7/16	-
FC250	Page M-14	Page M-27	Setscrew	Relube	4-Hole Piloted	Cast Iron	1/2 - 2-7/16	-
FR250W	Page M-14	Page M-27	Setscrew	Relube	3-Hole Bracket	Cast Iron	3/4 - 2s	-
FB350	Page M-37	Page M-38	Setscrew	Relube	4-Hole	Cast Iron	1 - 3-1/2	Page M-46
FB350H	Page M-37	Page M-39	Setscrew	Relube	4-Hole	HUB-ALLOY®	1 - 3-1/2	Page M-46
FC350	Page M-37	Page M-40	Setscrew	Relube	4-Hole Piloted	Cast Iron	1-1/4 - 3-1/2	Page M-46

IndustrialLine™ Bearings



Ball Bearing Take-Up Units

SERIES	RATING TABLES	OUTLINE DIMENSIONS	SHAFT LOCKING	BEARING LUBRICATION	SLOT WIDTH	HOUSING MATERIAL	SHAFT SIZE RANGE	INTERCHANGE REFERENCE
TU220	Page M-14	Page M-28	Eccentric Collar	Relube	Standard	Cast Iron	1/2 - 2-7/16	Page M-45
TU220W	Page M-14	Page M-29	Eccentric Collar	Relube	Standard	Cast Iron	3/4 - 2-7/16	Page M-45
TU250	Page M-14	Page M-28	Setscrew	Relube	Standard	Cast Iron	1/2 - 2-7/16	Page M-45
TU250W	Page M-14	Page M-29	Setscrew	Relube	Standard	Cast Iron	5/8 - 2-7/16	Page M-45
WSTU220	Page M-14	Page M-30	Eccentric Collar	Relube	Wide Slot	Cast Iron	3/4 - 2-7/16	Page M-45
WSTU250	Page M-14	Page M-30	Setscrew	Relube	Wide Slot	Cast Iron	3/4 - 2-7/16	Page M-45
WSTU220W	Page M-14	Page M-31	Eccentric Collar	Relube	Wide Slot	Cast Iron	1-7/16 - 3	Page M-45
WSTU250W	Page M-14	Page M-31	Setscrew	Relube	Wide Slot	Cast Iron	1-7/16 - 3	Page M-45
TU350	Page M-37	Page M-40	Setscrew	Relube	Standard	Cast Iron	1-7/16 - 3	-
WSTU350	Page M-37	Page M-41	Setscrew	Relube	Wide Slot	Cast Iron	1-7/16 - 3	-

DOWNLOAD AVAILABLE CAD MODELS AT: WWW.HUBCITYINC.COM

* WIDE SLOT UNITS AVAILABLE ON MADE-TO-ORDER BASIS.

Certified prints are available upon request

EMAIL: hubsales@regalbeloit.com • www.hubcityinc.com



Hub City IndustriaLine™ Bearing Units

Engineering and Selection Information

Maximum Speed

Maximum speed limits listed for the ball bearing products described in this catalog should be used as a guide and considered along with other factors affecting bearing operation. Load characteristics, bearing lubrication, and temperature factors all influence bearing operation. It is possible that cataloged speed limits may be exceeded after a complete application analysis is completed by factory engineers.

Bearing Life

Bearing life is commonly referred to in terms of the number of hours of operation at a given speed, that 90% of the bearings in a lot can equal or exceed before the onset of fatigue failure. This is called the L-10 life of a bearing.

The ball bearing unit load ratings published in this catalog are based upon AFBMA Standard Section 9, Load Ratings and Fatigue Life Ratings for Ball Bearings and are the steady radial loads at which the bearings will endure at various speeds for 500 hours L-10 life, or 2,500 hours average life (average life is considered to be 5 times L-10 life).

Bearing Loads

Radial loads and thrust force in combination are the principal load components of bearing applied loads. Hub City ball bearing unit ratings are based upon the radial load capacity of the bearing. For applications where bearings are required to absorb thrust forces in addition to normal radial loads, the following considerations must be made concerning the magnitude of the thrust force.

1. When thrust loads are less than 1/2 of the radial load – the equivalent load should be considered the same as the radial load and the selection made based upon the applied radial load.
2. When thrust loads are equal to or greater than 1/2 of the radial load – the equivalent load is determined by adding the radial and thrust loads together. The bearing selection is based upon using this total load as the equivalent applied radial load.

If thrust loads are equal to or exceed the radial loads, consult the factory.

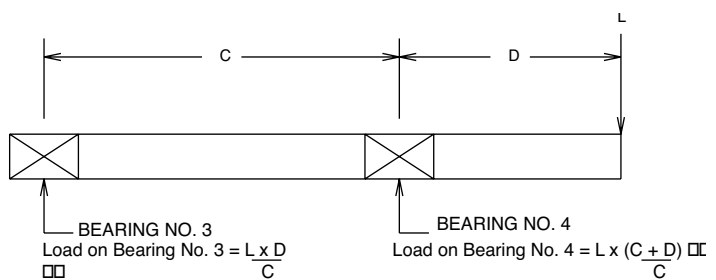
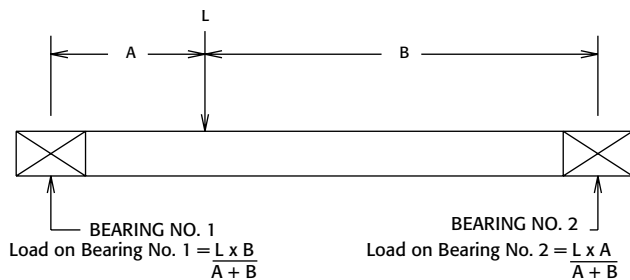

WHEN COMBINATION FORCES OR UNBALANCED LOADS ARE PRESENT, BEARING REACTION LOAD CALCULATIONS SHOULD BE REVIEWED WITH FACTORY ENGINEERING.

L = APPLIED EQUIVALENT LOAD

DOWNLOAD AVAILABLE CAD MODELS AT: WWW.HUBCITYINC.COM

Certified prints are available upon request

CALL: (605) 225-0360 • FAX: (605) 225-0567

Bearing Selection

Selection of the proper Hub City bearing unit for a determined speed and load can be made by referring to the load rating tables. Proper selection is made by finding a bearing having the desired bore size which has a load rating equal to or greater than the radial or equivalent radial load required for the application.

Engineering Data

Bearing reaction loads are caused by forces acting on the shaft supported by the bearings. These forces are a result of the weight of the shafting and components mounted on the shafting, bending loads due to belt or chain pull, gear reaction loads, and off center or unbalanced loads. These loads must be combined into a single resultant load of known magnitude and direction for each bearing.

Whether the load is applied between bearings on a shaft supported by two bearings or outboard of one of the bearings is important to proper bearing selection. The magnitude and direction of the load for either case may be calculated by taking moments about the other bearing.

Selection Example 1:

Radial Load Service Life Expectancy Selection

Select a mounted bearing pillow block unit to meet the following application requirements:

- a. Shaft diameter of 1 inch
- b. Shaft speed is 1500 RPM.
- c. Radial load requirement is 850 Lbs.
- d. Life requirement is 1000 hours L-10
(5000 hours average life)

Step 1.

From the rating tables on pages M-14 and M-37, locate the one inch shaft diameter line and follow that line to the right to the 1500 RPM column. Note that the radial load capacity for 100 Series bearings and 200 Series bearings (ratings, page M-14) is 890 pounds. The radial load capacity for 350 Series bearings (ratings, page M-37) is 1230 pounds.

Hub City IndustriaLine™ Bearing Units

Engineering and Selection Information

Selection Example 1:

Radial Load Service Life Expectancy Selection (cont.)

Step 2.

The published radial load capacities are based on an L-10 life of 500 hours and must be modified to suit the application requirement of 1000 hours L-10 life by using the proper multiplier from the chart below each rating table. Calculate the equivalent radial load capacity for 1000 hours L-10 life expectancy as follows:

For 100 or 200 Series Units

890 Lbs. radial capacity
x .794 1000 hours L-10 life factor
707 Lbs. radial capacity for 1000 hours L-10 life

For 350 Series: Units

1230 Lbs. radical capacity
x .794 1000 hours L-10 life factor
977 Lbs. radical capacity for 1000 hours L-10 life

Step 3.

The application radial load requirement of 850 pounds is greater than the radial load capacity for 1000 hours L-10 life for the 100 or 200 Series bearing units. The radial load capacity of the 350 Series bearing unit is 977 pounds and is greater than the application requirement of 650 pounds. A 350 Series bearing unit is the proper selection.

Since a mounted bearing pillow block is required, a 350 Series pillow block with 1 inch bore should be specified.

Selection Example 2:

Combination Radial and Thrust Load Requirement

Select a Hub City mounted bearing flange block to meet the following conditions:

- Shaft diameter is 1-3/16.
- A combination load is applied consisting of:
Radial load 400 pounds
Thrust load is 250 pounds
- Shaft speed is 500 RPM
- The L-10 life requirement is 500 hours (2500 hours average life)

Step 1.

From the load rating tables, M-14 and M-37, locate the 1-3/16 inch shaft size line and follow this line to the right to the 500 RPM column. The radial load capacity for 100 Series (page M-14) and 200 Series (page M-14) bearing units is 1780 pounds.

The radial load capacity for 350 Series (page M-37) bearing units is 2330 pounds.

Step 2.

Since the application L-10 life requirement of 500 hours is what the catalog rating charts are based on there's no need to apply further modifying factors.

Step 3.

Because the applied thrust load of 250 pounds is more than half of the applied radial load of 400 pounds, these loads must be added together to obtain the equivalent radial load requirement.

Equivalent Radial Load = 400 Lbs. + 250 Lbs. = 650 Lbs.

Step 4.

The equivalent radial load requirement of 650 pounds is less than the catalog radial load capacity for 100 Series, 200 Series, or 350 Series bearing units.

The application requirement is for a flange block unit. A choice must be made as to whether a 2-bolt, 3-bolt, or 4-bolt flange is desired.

The proper selection can then be made based on the preference for housing material (gray iron, or HUB-ALLOY®) and type of shaft locking preference (setscrew or eccentric collar locking) and whether a non-relube or relube type bearing is required.

For Lubrication and Mounting Instructions, Refer to section S

DOWNLOAD AVAILABLE CAD MODELS AT: WWW.HUBCITYINC.COM

Certified prints are available upon request

EMAIL: hubsales@regalbeloit.com • www.hubcityinc.com



Hub City IndustrialLine™ Bearing Units

HVAC Cast Iron Pillow Blocks



Series PB281WAH HVAC Bearing Units - for High Shaft Heights

- Squeeze lock collar for concentric 360 degree locking
- HVAC quality bearing insert with grade 10 balls
- Superfinished raceways
- Anti-rotation pins
- Air handling fit in housing
- Precision bored cast iron housing
- Wide inner race
- Nitrile rubber seals with steel flingers
- Prelubricated at factory with premium grease
- Noise tested

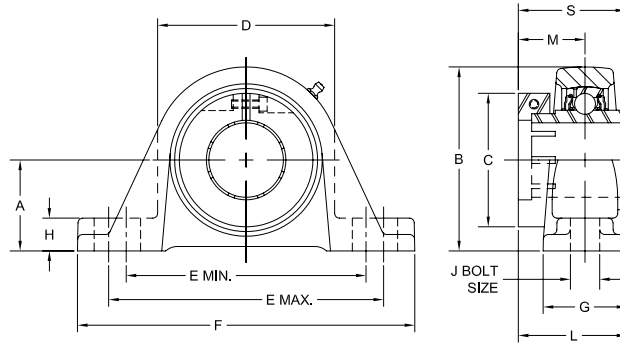

SHAFT SIZE	DIMENSIONS													WT. LBS.
	A	B	C	D	E		F	G	H	J	L	M	S	
					MIN.	MAX.								
3/4	1.938	2.563	1.756	2.250	3.250	4.125	5.125	1.375	0.563	0.375	1.563	0.870	1.370	2.0
1	1.438	2.750	1.937	2.500	3.500	4.500	5.500	1.500	0.625	0.375	1.719	0.950	1.510	2.5
1-3/16, 1-1/4S	1.688	3.250	2.185	3.000	4.250	5.125	6.375	1.750	0.750	0.500	1.875	1.030	1.650	3.1
1-1/4, 1-7/16	1.875	2.688	2.575	3.438	4.688	5.500	6.750	1.875	0.688	0.500	2.125	1.180	1.870	4.2
1-1/2	2, 2.188*	4.000	2.693	3.875	5.125	5.938	7.125	1.875	0.813	0.500	2.438	1.360	2.110	4.9
1-11/16, 1-3/4	2.188	4.250	2.933	4.125	5.375	6.125	7.375	2.000	0.813	0.500	2.438	1.370	2.120	5.5
1-15/16	2.250	4.500	3.386	4.313	5.813	6.750	8.375	2.000	0.813	0.625	2.656	1.520	2.270	6.5
2, 2-3/16	2.500	5.000	3.504	4.750	6.438	7.375	9.000	2.250	0.938	0.625	2.781	1.560	2.430	8.8
2-7/16	2.750	5.563	4.055	5.250	6.750	8.125	9.625	2.500	1.188	0.625	3.281	1.850	2.850	11.5

Part Numbers are specified by "PB281WAH" and Bore Size. Example: PB281WAH x 3/4.
For Load Ratings, see page M-14.

HVAC HubAlloy™ Four-Hole Flange Blocks

Series FB280HWAH HVAC Bearing Units

- Squeeze lock collar for concentric 360 degree locking
- HVAC quality bearing insert with grade 10 balls
- Superfinished raceways
- Anti-rotation pins
- Air handling fit in housing
- Precision bored Huballoy™ housing
- Higher strength and greater impact resistance
- Nitrile rubber seals with steel flingers
- Prelubricated at factory with premium grease
- Wide inner race
- Noise tested

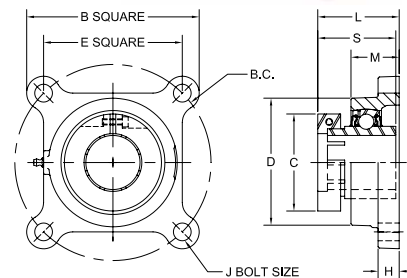

SHAFT SIZE	DIMENSIONS										WT. LBS.
	B	B.C.	C	D	E	H	J	L	M	S	
3/4	3.313	3.531	1.756	2.313	2.500	0.438	0.375	1.625	1.125	1.370	0.9
1	3.688	3.891	1.937	2.625	2.750	0.563	0.438	1.719	1.188	1.510	1.5
1-3/16, 1-1/4S	4.188	4.594	2.185	3.000	3.250	0.625	0.438	1.688	1.188	1.650	2.2
1-1/4, 1-7/16	4.688	5.125	2.575	3.500	3.625	0.656	0.500	2.000	1.250	1.870	2.8
1-1/2	5.063	5.656	2.693	3.875	4.000	0.688	0.500	2.313	1.438	2.110	3.7
1-11/16, 1-3/4	5.250	5.828	2.933	4.125	4.125	0.688	0.500	2.313	1.438	2.120	4.1
1-15/16	5.500	6.188	3.386	4.375	1.375	0.719	0.500	2.625	1.594	2.270	4.6
2, 2-3/16	6.375	7.250	3.504	4.750	5.125	0.719	0.625	2.781	1.781	2.430	6.2
2-7/16	6.875	7.938	4.055	5.313	5.625	0.813	0.625	3.188	1.938	2.850	8.5

Part Numbers are specified by "FB280HWAH" and Bore Size. Example: FB280HWAH x 3/4.
For Load Ratings, see page M-14.

DOWNLOAD AVAILABLE CAD MODELS AT: WWW.HUBCITYINC.COM

Certified prints are available upon request

CALL: (605) 225-0360 • FAX: (605) 225-0567



Hub City IndustrialLine™ Bearing Units

HVAC HubAlloy™ Two-Hole Flange Blocks

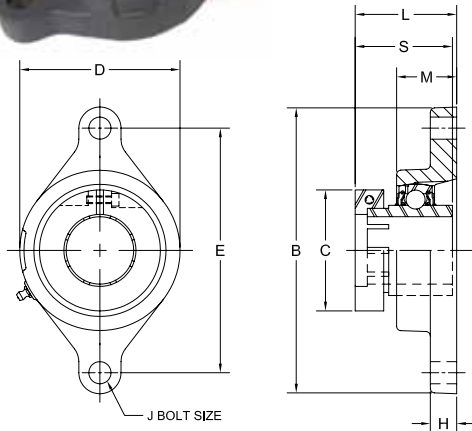

Series FB290HWAH HVAC Bearing Units

- Squeeze lock collar for concentric 360 degree locking
- HVAC quality bearing insert with grade 10 balls
- Superfinished raceways
- Anti-rotation pins
- Air handling fit in housing
- Precision bored Huballoy™ housing
- Higher strength and greater impact resistance
- Nitrile rubber seals with steel flingers
- Prelubricated at factory with premium grease
- Wide inner race
- Noise tested

SHAFT SIZE	DIMENSIONS									WT. LBS.
	B	C	D	E	H	J	L	M	S	
3/4	4.344	1.756	2.313	3.531	0.438	0.375	1.625	1.125	1.370	0.8
1	4.828	1.937	2.625	3.891	0.563	0.438	1.719	1.188	1.510	1.2
1-3/16, 1-1/4S	5.531	2.185	3.000	4.594	0.563	0.438	1.688	1.188	1.650	1.8
1-1/4, 1-7/16	6.188	2.575	3.500	5.125	0.563	0.500	2.000	1.250	1.870	2.4
1-1/2	6.719	2.693	3.875	5.656	0.563	0.500	2.313	1.438	2.110	3.1
1-11/16, 1-3/4	6.953	2.933	4.125	5.828	0.563	0.500	2.313	1.438	2.120	3.6
1-15/16	7.313	3.386	4.375	6.188	0.625	0.500	2.625	1.594	2.270	4.0
2, 2-3/16	8.500	3.504	4.750	7.250	0.781	0.625	2.781	1.781	2.430	5.2
2-7/16	9.688	4.055	5.313	7.938	0.813	0.750	3.188	1.938	2.850	7.7

Part Numbers are specified by "FB290HWAH" and Bore Size. Example: FB290HWAH x 3/4.
For Load Ratings, see page M-14.

HVAC Bearing Inserts

Series B280WAH

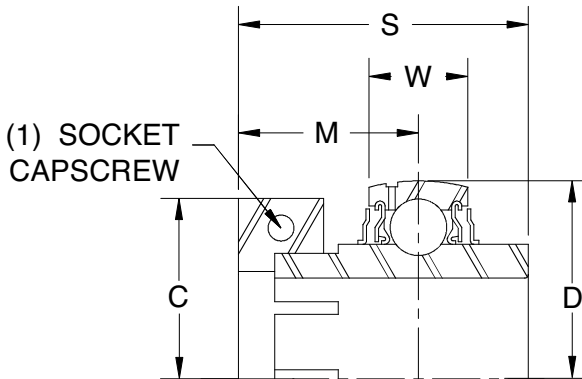

SHAFT SIZE	DIMENSIONS					SOCKET CAPSCREW	WT. LBS.
	C	D	M	S	W		
3/4	1.7560	1.8504	0.8700	1.3700	0.5910	8-32x5/8 UNF	0.3
1	1.9370	2.0472	0.9470	1.5100	0.5910	8-32x5/8 UNF	0.5
1-3/16, 1-1/4S	2.1850	2.4409	1.2040	1.6500	0.7090	8-32x5/8 UNF	0.7
1-1/4, 1-7/16	2.5750	2.8346	1.1810	1.8700	0.7480	10-24x3/4 UNC	1.0
1-1/2	2.6930	3.1496	1.6200	2.1100	0.8660	10-24x3/4 UNC	1.3
1-11/16, 1-3/4	2.9330	3.3465	1.3720	2.1200	0.8660	10-24x3/4 UNC	1.6
1-15/16	3.3860	3.5433	1.5220	2.2700	0.8660	1/4-20x1 UNC	1.6
2, 2-3/16	3.5040	3.9370	1.5560	2.4300	0.9840	1/4-20x1 UNC	2.5
2-7/16	4.0550	4.3307	1.8500	2.8500	1.0630	5/16-18x1 UNC	3.8

DOWNLOAD AVAILABLE CAD MODELS AT: WWW.HUBCITYINC.COM

Certified prints are available upon request

EMAIL: hubsales@regalbeloit.com • www.hubcityinc.com



Hub City IndustrialLine™ Bearing Units

Hub-Alloy® Pillow Blocks

Series PB120

- Relube type. Prelubricated at factory
- Eccentric lock collar
- Self-aligning replaceable bearing
- Nitrile rubber seals with steel trash guard
- Precision bored high strength HUB ALLOY® housing

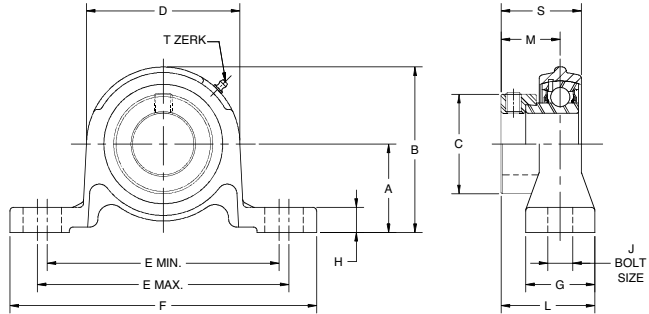

SHAFT SIZE	DIMENSIONS													WT. LBS.
	A	B	C	D	E		F	G	H	J	L	M	S	
					MIN.	MAX.								
1/2, 5/8	1.1870	2.1600	1.1010	2.1300	3.2200	3.6300	4.5000	0.9800	0.2800	0.4300	1.3600	0.8700	1.1260	0.6
3/4	1.3120	2.4400	1.2730	2.4000	3.5900	4.0300	4.9200	1.0600	0.3100	0.4300	1.4600	0.9250	1.2200	0.8
7/8, 1	1.4370	2.7200	1.4600	2.5600	3.7500	4.1200	5.1200	1.1400	0.3500	0.4100	1.5000	0.9250	1.2200	0.9
1-1/8, 1-3/16, 1-1/4s	1.6870	3.1900	1.7100	3.0000	4.4700	4.9700	6.1400	1.3000	0.3900	0.5500	1.7000	1.0510	1.4060	1.3
1-1/4, 1-3/8, 1-7/16	1.8750	3.5800	2.1480	3.4300	4.7500	5.2500	6.5000	1.3800	0.3900	0.5500	1.8500	1.1570	1.5310	1.9

Part Numbers are specified by "PB120" and Bore Size; Example: PB120 x 1-1/8.
For replacement inserts use B220 Bearing Inserts, see page M-35.
T-Zerk: 1/4-28 Taper

For Load Ratings, see page M-14.

Series PB150

- Relube type. Prelubricated at factory
- Setscrew locking
- Self-aligning replaceable bearing
- Nitrile rubber seals with steel trash guard
- Precision bored high strength HUB ALLOY® housing

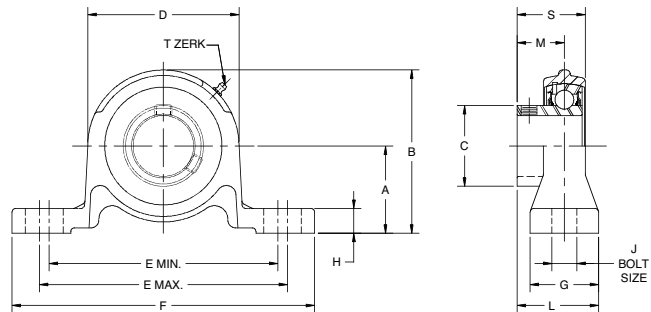

SHAFT SIZE	DIMENSIONS													WT. LBS.
	A	B	C	D	E		F	G	H	J	L	M	S	
					MIN.	MAX.								
1/2, 5/8	1.1875	2.1563	0.9530	1.9375	3.2188	3.6563	4.4375	1.0000	.3438	.3750	1.1250	0.6300	0.8860	0.6
3/4	1.3125	2.4375	1.1100	2.2500	3.5313	3.9688	4.7500	1.0625	.3438	.3750	1.2500	0.7200	1.0040	0.8
7/8, 15/16, 1	1.4375	2.6875	1.3280	2.5000	3.7188	4.1563	5.0000	1.1250	.4063	.3750	1.3125	0.7680	1.0710	1.0
1-1/8, 1-3/16, 1-1/4S	1.6875	3.1563	1.5630	2.9375	2.4375	5.0000	5.9375	1.3125	.4063	.5000	1.5156	0.8660	1.2200	1.4
1-1/4, 1-3/8, 1-7/16	1.8750	3.5625	1.8150	3.3750	4.7188	5.2813	6.2500	1.3750	.4375	.5000	1.6875	1.0040	1.3780	2.0

Part Numbers are specified by "PB150" and Bore Size; Example: PB150 x 1-1/8.
For Load Ratings, see page M-14.
For replacement inserts use B250 Bearing Inserts, see page M-35.
T-Zerk: 1/4-28 Taper

DOWNLOAD AVAILABLE CAD MODELS AT: WWW.HUBCITYINC.COM

Certified prints are available upon request

CALL: (605) 225-0360 • FAX: (605) 225-0567

Hub City IndustrialLine™ Bearing Units

Hub-Alloy® Flange Blocks

IndustrialLine™ Bearings

M

FB110 Two-Hole Flange Block

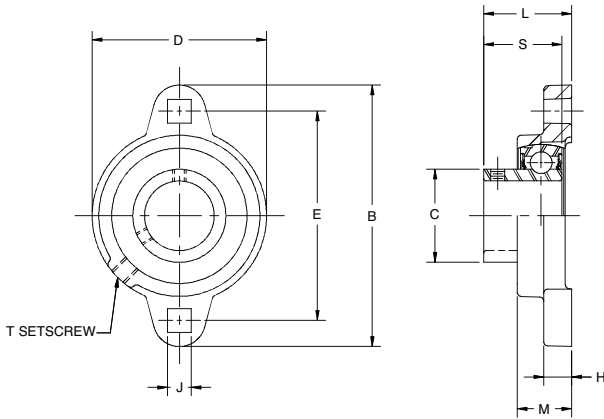

- Non-relube type. Prelubricated at factory
- Setscrew locking
- Self-aligning replaceable bearing
- Nitrile rubber seals with steel trash guard
- Precision bored high strength HUB-ALLOY® housing

SHAFT SIZE	DIMENSIONS									WT. LBS.
	B	C	D	E	H	J	L	M	S	
1/2, 5/8	3.1900	0.9530	2.2000	2.5000	0.3800	0.2800	1.0200	0.7100	0.8860	0.6
3/4	3.5400	1.1100	2.4000	2.8150	0.4300	0.3400	1.1600	0.7900	1.0040	0.8
7/8, 1	3.7400	1.3280	2.5200	2.9920	0.4300	0.3400	1.2080	0.7900	1.0710	0.8
1-1/8, 1-3/16, 1-1/4s	4.4500	1.5630	2.9900	3.5600	0.4700	0.4100	1.3790	0.8900	1.2200	1.1
1-1/4, 1-3/8, 1-7/16	4.8000	1.8150	3.5000	3.9370	0.5100	0.4100	1.5580	0.9400	1.3780	1.5

Part Numbers are specified by "FB110" and Bore Size; Example: FB110 x 1/2.

For Load Ratings, see page M-14. For Comparison Charts, see page M-36.

For replacement inserts use B250 Bearing Inserts, see page M-35.

Hub City IndustrialLine™ Bearing Units

Hub-Alloy® Flange Blocks

Series FB120, FB130

FB120 Three-Hole Flange Block

- Relube type. Prelubricated at factory
- Eccentric locking collar
- Self-aligning replaceable bearing
- Nitrile rubber seals with steel trash guard
- Precision bored high strength HUB-ALLOY® housing

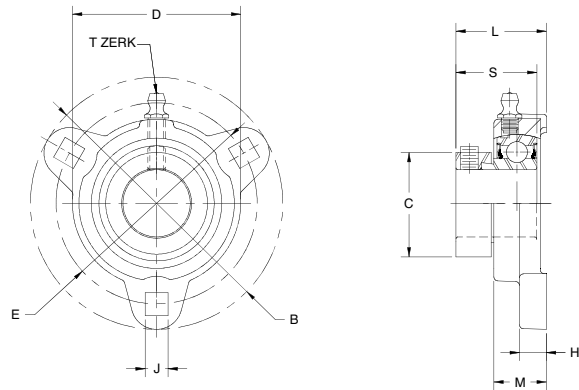

SHAFT SIZE	DIMENSIONS									WT. LBS.
	B	C	D	E	H	J	L	M	S	
1/2, 5/8	3.1900	1.1010	2.0500	2.5000	0.3900	0.2800	1.2800	0.6900	1.1260	0.6
3/4	3.5600	1.2730	2.4400	2.8110	0.3900	0.3400	1.3500	0.7800	1.2200	0.8
7/8, 1	3.7500	1.4600	2.8300	3.0000	0.4700	0.3400	1.3300	0.7800	1.2200	0.8
1-1/8, 1-3/16, 1-1/4s	4.4400	1.7100	3.3100	3.5630	0.4700	0.4100	1.5600	0.8700	1.4060	1.1
1-1/4, 1-3/8, 1-7/16	4.8000	2.1480	3.4600	3.9370	0.5300	0.4100	1.7300	0.9400	1.5310	1.7

Part Numbers are specified by "FB120" and Bore Size; Example: FB120 x 3/4.
 For Load Ratings, see page M-14. For Comparison Charts, see page M-42.
 For replacement inserts use B220 Bearing Inserts, see page M-35.
 T-Zerk: 1/4-28 Taper

FB130 Two-Hole Flange Block

- Relube type. Prelubricated at factory
- Eccentric locking collar
- Self-aligning replaceable bearing
- Nitrile rubber seals with steel trash guard
- Precision bored high strength HUB-ALLOY® housing

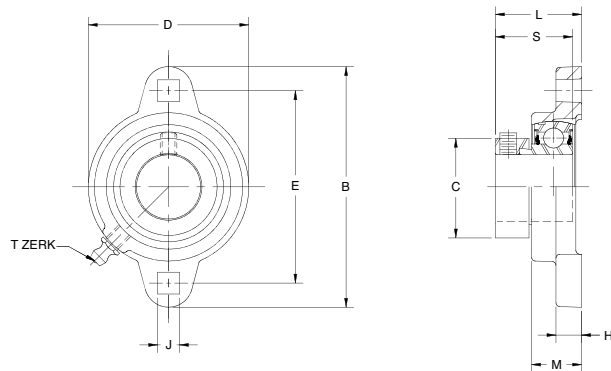

SHAFT SIZE	DIMENSIONS									WT. LBS.
	B	C	D	E	H	J	L	M	S	
1/2, 5/8	3.1900	1.1010	2.2000	2.5000	0.3800	0.2800	1.2600	0.7100	1.1260	0.6
3/4	3.5400	1.2730	2.4000	2.8150	0.4300	0.3400	1.3800	0.7900	1.2200	0.8
7/8, 1	3.7400	1.4600	2.5200	2.9920	0.4300	0.3400	1.3600	0.7900	1.2200	0.8
1-1/8, 1-3/16, 1-1/4s	4.4500	1.7100	2.9900	3.5600	0.4700	0.4100	1.5600	0.8900	1.4060	1.1
1-1/4, 1-3/8, 1-7/16	4.8000	2.1480	3.5000	3.9370	0.5100	0.4100	1.7100	0.9400	1.5310	1.5

Part Numbers are specified by "FB130" and Bore Size; Example: FB130 x 3/4.
 For Load Ratings, see page M-14. For Comparison Charts, see page M-42.
 For replacement inserts use B250 Bearing Inserts, see page M-35.
 T-Zerk: 1/4-28 Taper

⚠ DIMENSIONS SHOWN ARE FOR REFERENCE ONLY.

DOWNLOAD AVAILABLE CAD MODELS AT: WWW.HUBCITYINC.COM

Certified prints are available upon request

CALL: (605) 225-0360 • FAX: (605) 225-0567

Hub City IndustrialLine™ Bearing Units

Hub-Alloy® Flange Blocks

Series FB150, FB160

FB150 Three-Hole Flange Block

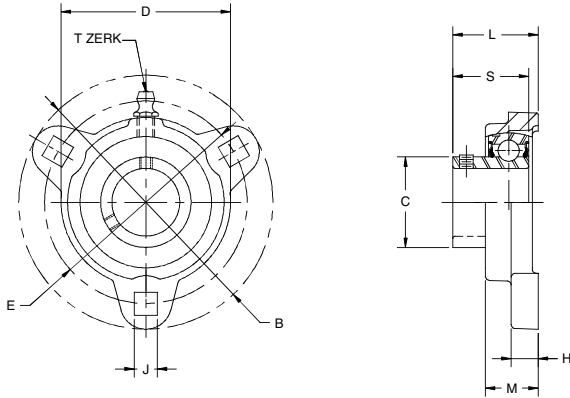

- Relube type. Prelubricated at factory
- Setscrew locking
- Self-aligning replaceable bearing
- Nitrile rubber seals with steel trash guard
- Precision bored high strength HUB-ALLOY® housing

SHAFT SIZE	DIMENSIONS									WT. LBS.
	B	C	D	E	H	J‡	L	M	S	
1/2, 5/8	3.1900	0.9530	2.0500	2.5000	0.3900	0.2800	1.0400	0.6900	0.8860	0.6
3/4	3.5600	1.1100	2.4400	2.8110	0.3900	0.3400	1.1600	0.7800	1.0040	0.8
7/8, 1	3.7500	1.3280	2.8300	3.0000	0.4700	0.3400	1.1780	0.7800	1.0710	0.8
1-1/8, 1-3/16, 1-1/4s	4.4400	1.5630	3.3100	3.5630	0.4700	0.4100	1.3790	0.8700	1.2200	1.1
1-1/4, 1-3/8, 1-7/16	4.8000	1.8150	3.4600	3.9370	0.5300	0.4100	1.5680	0.9400	1.3780	1.7

Part Numbers are specified by "FB150" and Bore Size; Example: FB150 x 3/4.

‡ Holes are cast, some variation may be expected.

For Load Ratings, see page M-14. For Comparison Charts, see page M-42.

For replacement inserts use B250 Bearing Inserts, see page M-35.

T-Zerk: 1/4-28 Taper

IndustrialLine™ Bearings



FB160 Three-Hole Flange Block

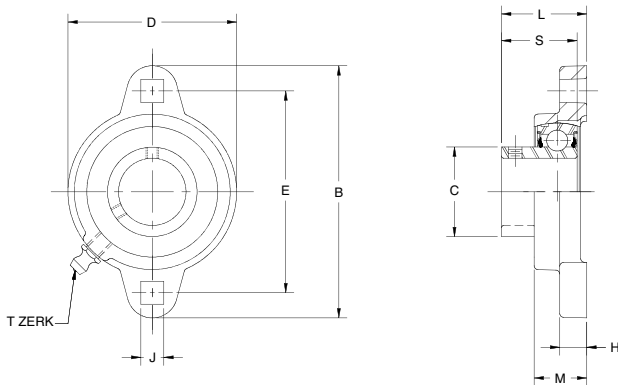

- Relube type. Prelubricated at factory
- Setscrew locking
- Self-aligning replaceable bearing
- Nitrile rubber seals with steel trash guard
- Precision bored high strength HUB-ALLOY® housing

SHAFT SIZE	DIMENSIONS									WT. LBS.
	B	C	D	E	H	J‡	L	M	S	
1/2, 5/8	3.1900	0.9530	2.2000	2.5000	0.3800	0.2800	1.0200	0.7100	0.8860	0.6
3/4	3.5400	1.1100	2.4000	2.8150	0.4300	0.3400	1.1600	0.7900	1.0040	0.8
7/8, 1	3.7400	1.3280	2.5200	2.9920	0.4300	0.3400	1.2080	0.7900	1.0710	0.8
1-1/8, 1-3/16, 1-1/4s	4.4500	1.5630	2.9900	3.5600	0.4700	0.4100	1.3790	0.8900	1.2200	1.1
1-1/4, 1-3/8, 1-7/16	4.8000	1.8150	3.5000	3.9370	0.5100	0.4100	1.5580	0.9400	1.3780	1.5

Part Numbers are specified by "FB160" and Bore Size; Example: FB160 x 3/4.

‡ Holes are cast, some variation may be expected.

For Load Ratings, see page M-14. For Comparison Charts, see page M-42.

For replacement inserts use B250 Bearing Inserts, see page M-35.

T-Zerk: 1/4-28 Taper

DOWNLOAD AVAILABLE CAD MODELS AT: WWW.HUBCITYINC.COM

Certified prints are available upon request

† DIMENSIONS SHOWN ARE FOR REFERENCE ONLY.

EMAIL: hubsales@regalbeloit.com • www.hubcityinc.com



Hub City IndustrialLine™ Bearing Units

Series 100, 200 - Ratings

SHAFT SIZE (INCHES)	BEARING RADIAL LOAD CAPACITY IN POUNDS BASED ON L-10 LIFE OF 500 HOURS AND STEADY LOAD CONDITIONS (2500 HOURS AVERAGE LIFE)							
	BEARING SPEED – REVOLUTIONS PER MINUTE (RPM)							
	100	500	1,000	1,500	2,000	2,500	3,000	3,500
1/2, 5/8	1,490	870	690	600	550	510	480	460
3/4	1,980	1,160	920	800	730	680	640	610
7/8, 15/16, 1	2,180	1,280	1,010	890	800	750	700	670
1-1/8, 1-3/16, 1-1/4S	3,040	1,780	1,410	1,230	1,120	1,040	980	930
1-1/4, 1-3/8, 1-7/16	3,980	2,330	1,850	1,610	1,470	1,360	1,280	—
1-1/2	4,790	2,800	2,220	1,940	1,760	1,640	1,540	—
1-5/8, 1-11/16, 1-3/4	5,180	3,030	2,400	2,100	1,910	1,770	—	—
1-15/16, 2S	5,480	3,200	2,540	2,220	2,020	1,870	—	—
2, 2-3/16	6,800	3,980	3,160	2,760	2,510	—	—	—
2-1/4, 2-7/16	8,250	4,830	3,830	3,350	3,040	—	—	—
2-15/16	9,710	5,680	4,510	3,940	—	—	—	—

For ultimate life, snug fit or light press on shaft should be used.
Recommended Operating Temperature Range: -25° to +225°F.

Maximum Recommended Speeds:*

- 1-7/16 and smaller — 3,500 R.P.M.
- 1-1/2 – 1-3/4 — 3,000 R.P.M.
- 1-7/8 – 2-7/16 — 2,500 R.P.M.
- 2-15/16 — 1,800 R.P.M.

For Applications not covered in the table above, consult the factory.

TO MODIFY THE ABOVE RATINGS FOR OTHER L-10 LIFE REQUIREMENTS OR FOR SHOCK LOADS MULTIPLY THE ABOVE RATINGS BY THE FACTOR FROM THIS CHART														
MODIFICATION FACTORS FOR L-10 SERVICE LIFE AND LOAD CONDITIONS:														
LOAD CONDITIONS	L-10 LIFE (HOURS)													
	500	700	1,000	1,500	2,000	3,000	4,000	5,000	7,000	10,000	15,000	20,000	30,000	50,000
Steady Load	1.00	.894	.794	.694	.630	.550	.500	.464	.415	.368	.322	.292	.255	.215
Light Shock	.90	.804	.715	.624	.567	.495	.450	.418	.373	.331	.290	.263	.230	.194
Moderate Shock	.70	.626	.556	.485	.441	.385	.350	.325	.290	.258	.225	.205	.179	.151

† DIMENSIONS SHOWN ARE FOR REFERENCE ONLY.

DOWNLOAD AVAILABLE CAD MODELS AT: WWW.HUBCITYINC.COM

Certified prints are available upon request

CALL: (605) 225-0360 • FAX: (605) 225-0567



Hub City IndustrialLine™ Bearing Units

Cast Iron Pillow Blocks

Series PB220, PB221

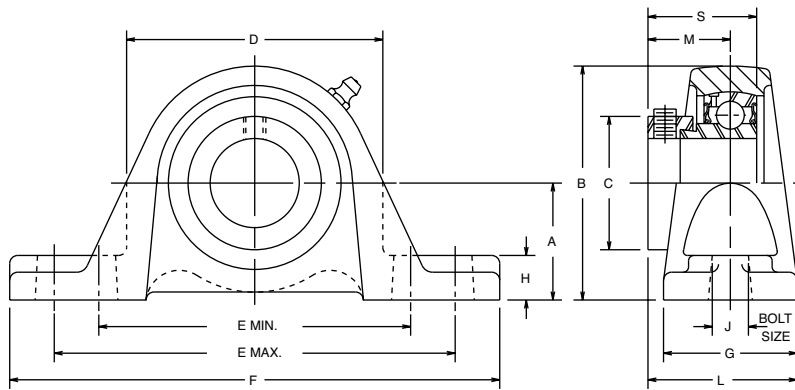

- Relube type. Prelubricated at factory
- Eccentric locking collar
- Self-aligning replaceable bearing
- Nitrile rubber seals with steel trash guard
- Precision bored Cast Iron housing

NOTE: BEARINGS WITH ECCENTRIC LOCKING COLLARS ARE NOT RECOMMENDED FOR USE IN REVERSING APPLICATIONS.

PB220 Series – For Low Shaft Heights

SHAFT SIZE	DIMENSIONS													WT. LBS.
	A	B	C	D	E		F	G	H	J	L	M	S	
					MIN.	MAX.								
1/2, 5/8	1.0625	2.1250	1.1010	1.9375	3.0000	3.9375	4.8750	1.2500	0.5000	0.3750	1.5469	0.9150	1.1260	1.1
3/4	1.2500	2.5000	1.2730	2.2500	3.2500	4.1250	5.1250	1.3750	0.5000	0.3750	1.6094	0.9250	1.2200	1.8
1	1.3125	2.6250	1.4600	2.5000	3.5000	4.5000	5.5000	1.5000	0.5000	0.3750	1.6719	0.9250	1.2200	2.3
1-1/8, 1-3/16, 1-1/4S	1.5625	3.1250	1.7100	3.0000	4.2500	5.1250	6.3750	1.7500	0.6250	0.5000	1.9219	1.0510	1.4060	2.8
1-1/4, 1-3/8, 1-7/16	1.8125	3.6250	2.1480	3.4375	4.6875	5.5000	6.7500	1.8750	0.6250	0.5000	2.0938	1.1570	1.5310	3.7
1-1/2	1.9375	3.9375	2.3350	3.8750	5.1250	5.9375	7.1250	1.8750	0.7500	0.5000	2.2031	1.2680	1.7200	4.2
1-11/16, 1-3/4	2.0625	4.1875	2.4830	4.1250	5.3750	6.2500	7.3750	2.0000	0.7500	0.5000	2.2813	1.2870	1.7200	4.8
1-15/16	2.1875	4.4375	2.7330	4.3125	5.8125	6.7500	8.3750	2.0000	0.7500	0.6250	2.2813	1.2870	1.7200	5.9
2, 2-3/16	2.4375	4.9375	2.9830	4.7500	6.4375	7.3750	9.0000	2.2500	0.8750	0.6250	2.5625	1.4390	1.9060	8.3
2-7/16	2.6875	5.5000	3.2960	5.2500	6.7500	8.1250	9.6250	2.5000	1.1250	0.6250	2.8125	1.5590	2.0910	10.9

Part Numbers are specified by "PB220" and Bore Size; Example: PB220 x 1-7/16.
 For Load Ratings, see page M-14. For Comparison Charts, see page M-43.
 For replacement inserts use B220 Bearing Inserts, see page M-35.
 T-Zerk: 1/4-28 Taper

PB221 Series – For High Shaft Heights

SHAFT SIZE	DIMENSIONS													WT. LBS.
	A	B	C	D	E		F	G	H	J	L	M	S	
					MIN.	MAX.								
1/2, 5/8	1.1875	2.2500	1.1010	1.9375	3.0000	3.9375	4.8750	1.2500	0.6250	0.3750	1.5469	0.9150	1.1260	1.2
3/4	1.3125	2.5625	1.2730	2.2500	3.2500	4.1250	5.1250	1.3750	0.5625	0.3750	1.6094	0.9250	1.2200	1.9
1	1.4375	2.7500	1.4600	2.5000	3.5000	4.5000	5.5000	1.5000	0.6250	0.3750	1.6719	0.9250	1.2200	2.4
1-1/8, 1-3/16, 1-1/4S	1.6875	3.2500	1.7100	3.0000	4.2500	5.1250	6.3750	1.7500	0.7500	0.5000	1.9219	1.0510	1.4060	2.9
1-1/4, 1-3/8, 1-7/16	1.8750	3.6875	2.1480	3.4375	4.6875	5.5000	6.7500	1.8750	0.6875	0.5000	2.0938	1.1570	1.5310	4.1
1-1/2	2.0000	4.0000	2.3350	3.8750	5.1250	5.9375	7.1250	1.8750	0.8125	0.5000	2.2031	1.2680	1.7200	4.3
1-11/16, 1-3/4	2.1250	4.2500	2.4830	4.1250	5.3750	6.2500	7.3750	2.0000	0.8125	0.5000	2.2813	1.2870	1.7200	4.9
1-15/16	2.2500	4.5000	2.7330	4.3125	5.8125	6.7500	8.3750	2.0000	0.8125	0.6250	2.2813	1.2870	1.7200	6.1
2, 2-3/16	2.5000	5.0000	2.9830	4.7500	6.4375	7.3750	9.0000	2.2500	0.9375	0.6250	2.5625	1.4390	1.9060	9.0
2-7/16	2.7500	5.5625	3.2960	5.2500	6.7500	8.1250	9.6250	2.5000	1.1875	0.6250	2.8125	1.5590	2.0910	11.1

Part Numbers are specified by "PB221" and Bore Size; Example: PB221 x 1-1/2.
 For Load Ratings, see page M-14. For Comparison Charts, see page M-43.
 For replacement inserts use B220 Bearing Inserts, see page M-35.
 T-Zerk: 1/4-28 Taper

DOWNLOAD AVAILABLE CAD MODELS AT: WWW.HUBCITYINC.COM
Certified prints are available upon request

† DIMENSIONS SHOWN ARE FOR REFERENCE ONLY.

Hub City IndustrialLine™ Bearing Units

Cast Iron Pillow Blocks

Series PB220W, PB221W

- Relube type. Prelubricated at factory
- Eccentric locking collar
- Self-aligning replaceable bearing
- Nitrile rubber seals with steel flingers
- Precision bored Cast Iron housing
- Wide inner race.

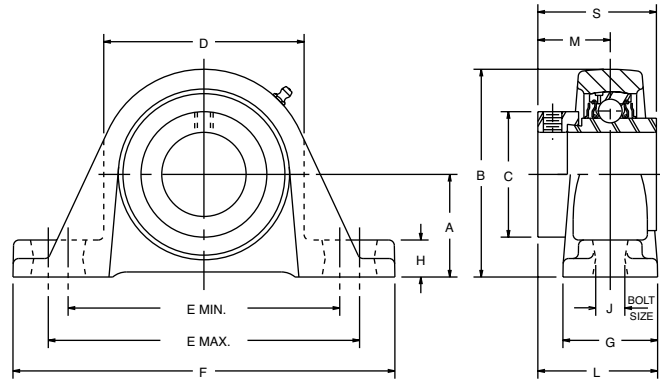

NOTE: BEARINGS WITH ECCENTRIC LOCKING COLLARS ARE NOT RECOMMENDED FOR USE IN REVERSING APPLICATIONS.

PB220W Series – For Low Shaft Heights

SHAFT SIZE	DIMENSIONS													WT. LBS.
	A	B	C	D	E		F	G	H	J	L	M	S	
					MIN.	MAX.								
1	1.3125	2.6250	1.4600	2.5000	3.5000	4.5000	5.5000	1.5000	0.5000	0.3750	1.8125	1.0590	1.7480	2.3
1-3/16	1.5625	3.1250	1.7100	3.0000	4.2500	5.1250	6.3750	1.7500	0.6250	0.5000	2.0625	1.1850	1.9060	2.8
1-1/4, 1-3/8, 1-7/16	1.8125	3.6250	2.1480	3.4375	4.6875	5.5000	6.7500	1.8750	0.6250	0.5000	2.2188	1.2720	2.0120	3.7
1-1/2	1.9375	3.9375	2.3350	3.8750	5.1250	5.9375	7.1250	1.8750	0.7500	0.5000	2.3125	1.3740	2.2170	4.2
1-11/16, 1-3/4	2.0625	4.1875	2.4830	4.1250	5.3750	6.2500	7.3750	2.0000	0.7500	0.5000	2.3750	1.3740	2.2170	4.8
1-15/16	2.1875	4.4375	2.7330	4.3125	5.8125	6.7500	8.3750	2.0000	0.7500	0.6250	2.5000	1.5000	2.4690	5.9
2, 2-3/16	2.4375	4.9375	2.9830	4.7500	6.4375	7.3750	9.0000	2.2500	0.8750	0.6250	2.8438	1.7170	2.8110	8.3
2-7/16	2.6875	5.5000	3.2960	5.2500	6.7500	8.1250	9.6250	2.5000	1.1250	0.6250	3.0938	1.8380	3.0630	10.9

Part Numbers are specified by "PB220W" and Bore Size; Example: PB220W x 1-7/16.

For Load Ratings, see page M-14. For Comparison Charts, see page M-43.

For replacement inserts use YW220 Bearing Inserts, see page M-36.

T-Zerk: 1/4-28 Taper

PB221W Series – For High Shaft Heights

SHAFT SIZE	DIMENSIONS													WT. LBS.
	A	B	C	D	E		F	G	H	J	L	M	S	
					MIN.	MAX.								
1	1.4375	2.7500	1.4600	2.5000	3.5000	4.5000	5.5000	1.5000	0.6250	0.3750	1.8125	1.0590	1.7480	2.4
1-3/16	1.6875	3.2500	1.7100	3.0000	4.2500	5.1250	6.3750	1.7500	0.7500	0.5000	2.0625	1.1850	1.9060	2.9
1-1/4, 1-3/8, 1-7/16	1.8750	3.6875	2.1480	3.4375	4.6875	5.5000	6.7500	1.8750	0.6875	0.5000	2.2188	1.2720	2.0120	4.1
1-1/2	2.0000	4.0000	2.3350	3.8750	5.1250	5.9375	7.1250	1.8750	0.8125	0.5000	2.3125	1.3740	2.2170	4.3
1-11/16, 1-3/4	2.1250	4.2500	2.4830	4.1250	5.3750	6.2500	7.3750	2.0000	0.8125	0.5000	2.3750	1.3740	2.2170	4.9
1-15/16	2.2500	4.5000	2.7330	4.3125	5.8125	6.7500	8.3750	2.0000	0.8125	0.6250	2.5000	1.5000	2.4690	6.1
2, 2-3/16	2.5000	5.0000	2.9830	4.7500	6.4375	7.3750	9.0000	2.2500	0.9375	0.6250	2.8438	1.7170	2.8110	9.0
2-7/16	2.7500	5.5625	3.2960	5.2500	6.7500	8.1250	9.6250	2.5000	1.1875	0.6250	3.0938	1.8380	3.0630	11.1

Part Numbers are specified by "PB221W" and Bore Size; Example: PB221W x 1-1/2.

For Load Ratings, see page M-14. For Comparison Charts, see page M-43.

For replacement inserts use YW220 Bearing Inserts, see page M-36.

T-Zerk: 1/4-28 Taper

† DIMENSIONS SHOWN ARE FOR REFERENCE ONLY.

DOWNLOAD AVAILABLE CAD MODELS AT: WWW.HUBCITYINC.COM

Certified prints are available upon request

CALL: (605) 225-0360 • FAX: (605) 225-0567

Hub City IndustrialLine™ Bearing Units

Hub-Alloy® Pillow Blocks

Series PB220HW, PB221HW

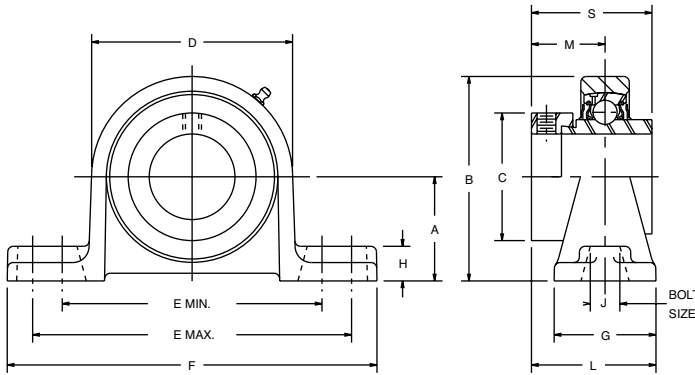

- Relube type. Prelubricated at factory
- Eccentric locking collar
- Self-aligning replaceable bearing
- Nitrile rubber seals with steel flingers
- Precision bored HUB-ALLOY® housing
- Higher strength and greater impact resistance than gray iron for high shock loads
- Wide inner race

NOTE: BEARINGS WITH ECCENTRIC LOCKING COLLARS ARE NOT RECOMMENDED FOR USE IN REVERSING APPLICATIONS.

PB220HW Series – For Low Shaft Heights

SHAFT SIZE	DIMENSIONS													WT. LBS.
	A	B	C	D	E		F	G	H	J	L	M	S	
					MIN.	MAX.								
1	1.3125	2.6250	1.4600	2.5000	3.6250	4.5000	5.3750	1.5000	0.5000	0.3750	1.8125	1.0590	1.7480	1.6
1-3/16	1.5625	3.0938	1.7100	2.9375	4.2500	5.1250	6.0625	1.5000	0.5625	0.5000	1.9375	1.1850	1.9060	2.5
1-1/4, 1-3/8, 1-7/16	1.8125	3.5313	2.1480	3.3750	4.6250	5.5000	6.4375	1.7500	0.5625	0.5000	2.1406	1.2720	2.0120	3.2
1-1/2	1.9375	3.8125	2.3350	3.7500	4.9375	5.8125	6.8750	1.7500	0.6250	0.5000	2.2500	1.3740	2.2170	3.6
1-11/16, 1-3/4	2.0625	4.0625	2.4830	4.0000	5.3125	6.1875	7.2500	1.8750	0.7500	0.5000	2.3125	1.3740	2.2170	4.3
1-15/16	2.1875	4.3125	2.7330	4.2500	5.8125	6.6875	7.8750	2.1250	0.7500	0.6250	2.5625	1.5000	2.4690	5.3
2, 2-3/16	2.4375	4.7813	2.9830	4.6875	6.0625	7.4375	8.6250	2.3750	0.8125	0.6250	2.9063	1.7170	2.8110	6.8
2-7/16	2.6875	5.2813	3.2960	5.1875	6.9375	8.0625	9.2500	2.3750	0.8750	0.6250	3.0313	1.8380	3.0630	9.1

Part Numbers are specified by "PB220HW" and Bore Size; Example: PB220HW x 1-7/16.

For Load Ratings, see page M-14. For Comparison Charts, see page M-43.

For replacement inserts use YW220 Bearing Inserts, see page M-36.

T-Zerk: 1/4-28 Taper

PB221HW Series – For High Shaft Heights

SHAFT SIZE	DIMENSIONS													WT. LBS.
	A	B	C	D	E		F	G	H	J	L	M	S	
					MIN.	MAX.								
1	1.4375	2.7500	1.4600	2.5000	3.6250	4.5000	5.3750	1.5000	0.6250	0.3750	1.8125	1.0590	1.7480	1.9
1-3/16	1.6875	3.2188	1.7100	2.9375	4.2500	5.1250	6.0625	1.5000	0.6875	0.5000	1.9375	1.1850	1.9060	2.6
1-1/4, 1-3/8, 1-7/16	1.8750	3.5938	2.1480	3.3750	4.6250	5.5000	6.4375	1.7500	0.6250	0.5000	2.1406	1.2720	2.0120	3.3
1-1/2	2.0000	3.8750	2.3350	3.7500	4.9375	5.8125	6.8750	1.7500	0.6875	0.5000	2.2500	1.3740	2.2170	3.9
1-11/16, 1-3/4	2.1250	4.2500	2.4830	4.0000	5.3125	6.1875	7.2500	1.8750	0.8125	0.5000	2.3125	1.3740	2.2170	4.6
1-15/16	2.2500	4.3750	2.7330	4.2500	5.8125	6.6875	7.8750	2.1250	0.8125	0.6250	2.5625	1.5000	2.4690	5.6
2, 2-3/16	2.5000	4.8438	2.9830	4.6875	6.0625	7.4375	8.6250	2.3750	0.8750	0.6250	2.9063	1.7170	2.8110	6.8
2-7/16	2.7500	5.3438	3.2960	5.1875	6.9375	8.0625	9.2500	2.3750	0.9375	0.6250	3.0313	1.8380	3.0630	9.6

Part Numbers are specified by "PB221HW" and Bore Size; Example: PB221HW x 1-1/2.

For Load Ratings, see page M-14. For Comparison Charts, see page M-43.

For replacement inserts use YW220 Bearing Inserts, see page M-36.

T-Zerk: 1/4-28 Taper

DOWNLOAD AVAILABLE CAD MODELS AT: WWW.HUBCITYINC.COM

Certified prints are available upon request

† DIMENSIONS SHOWN ARE FOR REFERENCE ONLY.

EMAIL: hubsales@regalbeloit.com • www.hubcityinc.com



M-17

IndustrialLine™ Bearings



Hub City IndustrialLine™ Bearing Units

Cast Iron Pillow Blocks

Series PB250, PB251

- Relube type. Prelubricated at factory
- Setscrew locking
- Self-aligning replaceable bearing
- Nitrile rubber seals with steel trash guard
- Precision bored Cast Iron housing

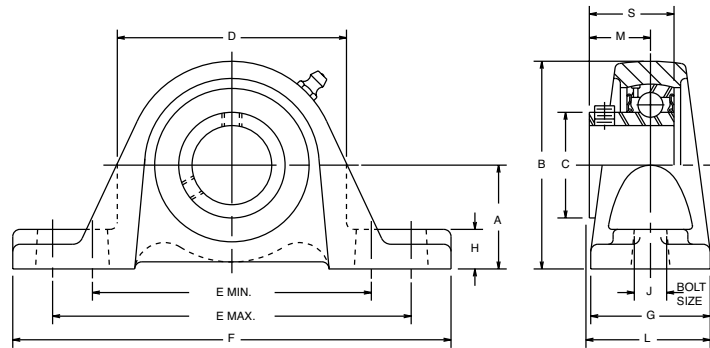

PB250 Series – For Low Shaft Heights

SHAFT SIZE	DIMENSIONS													WT. LBS.
	A	B	C	D	E		F	G	H	J	L	M	S	
					MIN.	MAX.								
1/2, 5/8	1.0625	2.1250	0.9530	1.9375	3.0000	3.9375	4.8750	1.2500	0.5000	0.3750	1.2969	0.6750	0.8860	1.2
3/4	1.2500	2.5000	1.1100	2.2500	3.2500	4.1250	5.1250	1.3750	0.5000	0.3750	1.4063	0.7200	1.0040	1.8
7/8, 15/16, 1	1.3125	2.6250	1.3280	2.5000	3.5000	4.5000	5.5000	1.5000	0.5000	0.3750	1.5156	0.7680	1.0710	2.3
1-1/8, 1-3/16, 1-1/4S	1.5625	3.1250	1.5630	3.0000	4.2500	5.1250	6.3750	1.7500	0.6250	0.5000	1.7344	0.8660	1.2200	2.8
1-1/4, 1-3/8, 1-7/16	1.8125	3.6250	1.8150	3.4375	4.6875	5.5000	6.7500	1.8750	0.6250	0.5000	1.9375	1.0040	1.3780	3.6
1-1/2	1.9375	3.9375	2.0390	3.8750	5.1250	5.9375	7.1250	1.8750	0.7500	0.5000	2.0625	1.1220	1.5750	4.5
1-5/8, 1-11/16, 1-3/4	2.0625	4.1875	2.2360	4.1250	5.3750	6.2500	7.3750	2.0000	0.7500	0.5000	2.2031	1.2010	1.6340	5.1
1-15/16, 2S	2.1875	4.4375	2.4610	4.3125	5.8125	6.7500	8.3750	2.0000	0.7500	0.6250	2.2656	1.2600	1.6930	6.0
2, 2-3/16	2.4375	4.9375	2.7190	4.7500	6.4375	7.3750	9.0000	2.2500	0.8750	0.6250	2.4063	1.2800	1.7720	8.2
2-1/4, 2-7/16	2.6875	5.5000	2.9780	5.2500	6.7500	8.1250	9.6250	2.5000	1.1250	0.6250	2.6250	1.3780	1.9090	10.9
2-15/16	3.2500	6.5000	3.6240	6.2500	7.8750	9.6250	11.2500	3.0000	1.1250	0.7500	3.0313	1.5350	2.1060	16.9

Part Numbers are specified by "PB250" and Bore Size.

Example: PB250 x 1-11/16.

For Load Ratings, see page M-14. For Comparison Charts, see page M-43.

For replacement inserts use B250 Bearing Inserts, see page M-35.

T-Zerk: 1/4-28 Taper

PB251 Series – For High Shaft Heights

SHAFT SIZE	DIMENSIONS													WT. LBS.
	A	B	C	D	E		F	G	H	J	L	M	S	
					MIN.	MAX.								
1/2, 5/8	1.1875	2.2500	0.9530	1.9375	3.0000	3.9375	4.8750	1.2500	0.6250	0.3750	1.2969	0.6750	0.8860	1.3
3/4	1.3125	2.5625	1.1100	2.2500	3.2500	4.1250	5.1250	1.3750	0.5625	0.3750	1.4063	0.7200	1.0040	1.9
7/8, 15/16, 1	1.4375	2.7500	1.3280	2.5000	3.5000	4.5000	5.5000	1.5000	0.6250	0.3750	1.5156	0.7680	1.0710	2.4
1-1/8, 1-3/16, 1-1/4S	1.6875	3.2500	1.5630	3.0000	4.2500	5.1250	6.3750	1.7500	0.7500	0.5000	1.7344	0.8660	1.2200	2.9
1-1/4, 1-3/8, 1-7/16	1.8750	3.6875	1.8150	3.4375	4.6875	5.5000	6.7500	1.8750	0.6875	0.5000	1.9375	1.0040	1.3780	4.0
1-1/2	2.0000	4.0000	2.0390	3.8750	5.1250	5.9375	7.1250	1.8750	0.8125	0.5000	2.0625	1.1220	1.5750	4.6
1-5/8, 1-11/16, 1-3/4	2.1250	4.2500	2.2360	4.1250	5.3750	6.2500	7.3750	2.0000	0.8125	0.5000	2.2031	1.2010	1.6340	5.2
1-15/16, 2S	2.2500	4.5000	2.4610	4.3125	5.8125	6.7500	8.3750	2.0000	0.8125	0.6250	2.2656	1.2600	1.6930	6.2
2, 2-3/16	2.5000	5.0000	2.7190	4.7500	6.4375	7.3750	9.0000	2.2500	0.9375	0.6250	2.4063	1.2800	1.7720	8.4
2-1/4, 2-7/16	2.7500	5.5625	2.9780	5.2500	6.7500	8.1250	9.6250	2.5000	1.1875	0.6250	2.6250	1.3780	1.9090	11.1
2-15/16	3.3125	6.5000	3.6240	6.2500	7.8750	9.6250	11.2500	3.0000	1.1875	0.7500	3.0313	1.5350	2.1060	17.1

Part Numbers are specified by "PB251" and Bore Size. Example: PB251 x 1-5/8.

For Load Ratings, see page M-14. For Comparison Charts, see page M-43.

For replacement inserts use B250 Bearing Inserts, see page M-35.

* PB251 x 1-1/2 with 2-1/8" "A" dimension available as special.

T-Zerk: 1/4-28 Taper

† DIMENSIONS SHOWN ARE FOR REFERENCE ONLY.

DOWNLOAD AVAILABLE CAD MODELS AT: WWW.HUBCITYINC.COM

Certified prints are available upon request

CALL: (605) 225-0360 • FAX: (605) 225-0567

Hub City IndustrialLine™ Bearing Units

Cast Iron Pillow Blocks

Series PB250W, PB251W

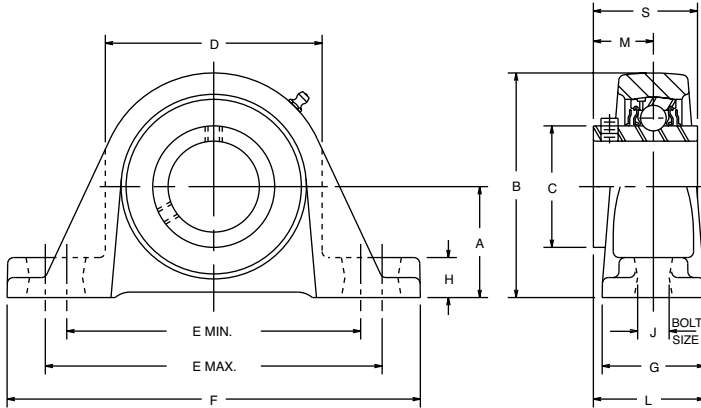

- Relube type. Prelubricated at factory
- Setscrew locking
- Self-aligning replaceable bearing
- Nitrile rubber seals with steel flingers
- Precision bored Cast Iron housing
- Wide inner race

PB250W Series - For Low Shaft Heights

SHAFT SIZE	DIMENSIONS													WT. LBS.
	A	B	C	D	E		F	G	H	J	L	M	S	
					MIN.	MAX.								
5/8	1.0625	2.1250	0.9530	1.9375	3.0000	3.9375	4.8750	1.2500	0.5000	0.3750	1.2656	0.6700	1.0790	1.2
3/4	1.2500	2.5000	1.1100	2.2500	3.2500	4.1250	5.1250	1.3750	0.5000	0.3750	1.4063	0.7200	1.2200	1.8
1	1.3125	2.6250	1.3280	2.5000	3.5000	4.5000	5.5000	1.5000	0.5000	0.3750	1.5313	0.7800	1.3430	2.3
1-3/16, 1-1/4S	1.5625	3.1250	1.5630	3.0000	4.2500	5.1250	6.3750	1.7500	0.6250	0.5000	1.7500	0.8740	1.5000	2.8
1-1/4, 1-7/16	1.8125	3.6250	1.8150	3.4375	4.6875	5.5000	6.7500	1.8750	0.6250	0.5000	1.9375	1.0000	1.6890	3.5
1-1/2	1.9375	3.9375	2.0390	3.8750	5.1250	5.9375	7.1250	1.8750	0.7500	0.5000	2.1250	1.1890	1.9370	4.5
1-3/4	2.0625	4.1875	2.2360	4.1250	5.3750	6.2500	7.3750	2.0000	0.7500	0.5000	2.1875	1.1890	1.9370	5.1
1-15/16	2.1875	4.4375	2.4610	4.3125	5.8125	6.7500	8.3750	2.0000	0.7500	0.6250	2.2813	1.2830	2.0310	6.0
2	2.4375	4.9375	2.7190	4.7500	6.4375	7.3750	9.0000	2.2500	0.8750	0.6250	2.4375	1.3150	2.1890	8.2
2-1/4, 2-7/16	2.6875	5.5000	2.9780	5.2500	6.7500	8.1250	9.6250	2.5000	1.1250	0.6250	2.8125	1.5660	2.5660	10.9

Part Numbers are specified by "PB250W" and Bore Size. Example: PB250W x 1-11/16.

For Load Ratings, see page M-14. For Comparison Charts, see page M-43.

For replacement inserts use YW250 Bearing Inserts, see page M-36.

T-Zerk: 1/4-28 Taper

PB251W Series - For High Shaft Heights

SHAFT SIZE	DIMENSIONS													WT. LBS.
	A	B	C	D	E		F	G	H	J	L	M	S	
					MIN.	MAX.								
5/8	1.1875	2.2500	0.9530	1.9375	3.0000	3.9375	4.8750	1.2500	0.6250	0.3750	1.2656	0.6700	1.0790	1.3
3/4	1.3125	2.5625	1.1100	2.2500	3.2500	4.1250	5.1250	1.3750	0.5625	0.3750	1.4063	0.7200	1.2200	1.9
1	1.4375	2.7500	1.3280	2.5000	3.5000	4.5000	5.5000	1.5000	0.6250	0.3750	1.5313	0.7800	1.3430	2.4
1-3/16, 1-1/4S	1.6875	3.2500	1.5630	3.0000	4.2500	5.1250	6.3750	1.7500	0.7500	0.5000	1.7500	0.8740	1.5000	2.9
1-1/4, 1-7/16	1.8750	3.6875	1.8150	3.4375	4.6875	5.5000	6.7500	1.8750	0.6875	0.5000	1.9375	1.0000	1.6890	4.0
1-1/2	2.0000	4.0000	2.0390	3.8750	5.1250	5.9375	7.1250	1.8750	0.8125	0.5000	2.1250	1.1890	1.9370	4.6
1-3/4	2.1250	4.2500	2.2360	4.1250	5.3750	6.2500	7.3750	2.0000	0.8125	0.5000	2.1875	1.1890	1.9370	5.2
1-15/16	2.2500	4.5000	2.4610	4.3125	5.8125	6.7500	8.3750	2.0000	0.8125	0.6250	2.2813	1.2830	2.0310	6.2
2	2.5000	5.0000	2.7190	4.7500	6.4375	7.3750	9.0000	2.2500	0.9375	0.6250	2.4375	1.3150	2.1890	8.4
2-1/4, 2-7/16	2.7500	5.5625	2.9780	5.2500	6.7500	8.1250	9.6250	2.5000	1.1875	0.6250	2.8125	1.5660	2.5660	11.1

Part Numbers are specified by "PB251W" and Bore Size. Example: PB251W x 1-5/8.

For Load Ratings, see page M-14. For Comparison Charts, see page M-43.

For replacement inserts use YW250 Bearing Inserts, see page M-36.

* PB251W x 1-1/2 with 2-1/8" "A" dimension available as special.

T-Zerk: 1/4-28 Taper

DOWNLOAD AVAILABLE CAD MODELS AT: WWW.HUBCITYINC.COM

Certified prints are available upon request

† DIMENSIONS SHOWN ARE FOR REFERENCE ONLY.

EMAIL: hubsales@regalbeloit.com • www.hubcityinc.com



Hub City IndustrialLine™ Bearing Units

Hub-Alloy® Pillow Blocks

Series PB250HW, PB251HW

- Relube type. Prelubricated at factory
- Setscrew locking
- Self-aligning replaceable bearing
- Nitrile rubber seals with steel flingers
- Precision bored HUB-ALLOY® housing
- Higher strength and greater impact resistance than gray iron for high shock loads
- Wide inner race

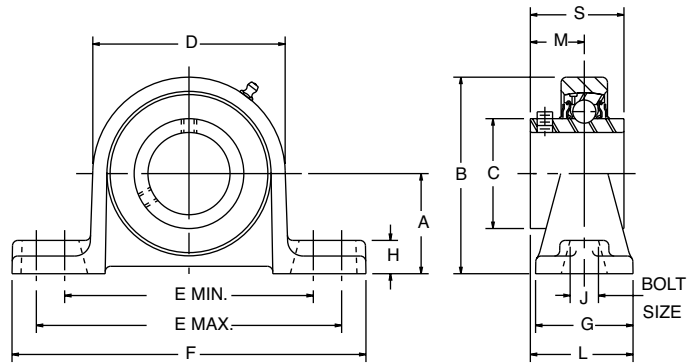

PB250HW Series - For Low Shaft Heights

SHAFT SIZE	DIMENSIONS													WT. LBS.
	A	B	C	D	E		F	G	H	J	L	M	S	
					MIN.	MAX.								
5/8	1.0625	2.1563	0.9530	1.9375	2.9375	3.8125	4.6250	1.1875	0.4375	0.3750	1.2344	0.6460	1.0790	0.8
3/4	1.2500	2.4688	1.1100	2.2500	3.3125	4.1875	5.0000	1.3750	0.4375	0.3750	1.4063	0.7200	1.2200	1.0
1	1.3125	2.6250	1.3280	2.5000	3.6250	4.5000	5.3750	1.5000	0.5000	0.3750	1.5313	0.7800	1.3430	1.6
1-3/16, 1-1/4S	1.5625	3.0938	1.5630	2.9375	4.2500	5.1250	6.0625	1.5000	0.5625	0.5000	1.6250	0.8740	1.5000	2.1
1-1/4, 1-7/16	1.8125	3.5313	1.8150	3.3750	4.6250	5.5000	6.4375	1.7500	0.5625	0.5000	1.8750	1.0000	1.6890	2.9
1-1/2	1.9375	3.8125	2.0390	3.7500	4.9375	5.8125	6.8750	1.7500	0.6250	0.5000	2.0625	1.1890	1.9370	3.5
1-3/4	2.0625	4.0625	2.2360	4.0000	5.3125	6.1875	7.2500	1.8750	0.7500	0.5000	2.1250	1.1890	1.9370	4.2
1-15/16	2.1875	4.3125	2.4610	4.2500	5.8125	6.6875	7.8750	2.1250	0.7500	0.6250	2.3438	1.2830	2.0310	5.1
2	2.4375	4.7813	2.7190	4.6875	6.0625	7.4375	8.6250	2.3750	0.8125	0.6250	2.5000	1.3150	2.1890	6.1
2-1/4, 2-7/16	2.6875	5.2813	2.9780	5.1875	6.9375	8.0625	9.2500	2.3750	0.8750	0.6250	2.7500	1.5660	2.5660	9.4

Part Numbers are specified by "PB250HW" and Bore Size. Example: PB250HW x 1 11/16.

For Load Ratings, see page M-14. For Comparison Charts, see page M-43.

For replacement inserts use YW250 Bearing Inserts, see page M-36.

T-Zerk: 1/4-28 Taper

PB251HW Series - For High Shaft Heights

SHAFT SIZE	DIMENSIONS													WT. LBS.
	A	B	C	D	E		F	G	H	J	L	M	S	
					MIN.	MAX.								
5/8	1.1875	2.2813	0.9530	1.9375	2.9375	3.8125	4.6250	1.1875	0.5625	0.3750	1.2344	0.6460	1.0790	0.9
3/4	1.3125	2.5313	1.1100	2.2500	3.3125	4.1875	5.0000	1.3750	0.5000	0.3750	1.4063	0.7200	1.2200	1.1
1	1.4375	2.7500	1.3280	2.5000	3.6250	4.5000	5.3750	1.5000	0.6250	0.3750	1.5313	0.7800	1.3430	1.7
1-3/16, 1-1/4S	1.6875	3.2188	1.5630	2.9375	4.2500	5.1250	6.0625	1.5000	0.6875	0.5000	1.6250	0.8740	1.5000	2.5
1-1/4, 1-7/16	1.8750	3.5938	1.8150	3.3750	4.6250	5.5000	6.4375	1.7500	0.6250	0.5000	1.8750	1.0000	1.6890	2.9
1-1/2	2.0000	3.8750	2.0390	3.7500	4.9375	5.8125	6.8750	1.7500	0.6875	0.5000	2.0625	1.1890	1.9370	3.6
1-3/4	2.1250	4.1250	2.2360	4.0000	5.3125	6.1875	7.2500	1.8750	0.8125	0.5000	2.1250	1.1890	1.9370	4.2
1-15/16	2.2500	4.3750	2.4610	4.2500	5.8125	6.6875	7.8750	2.1250	0.8125	0.6250	2.3438	1.2830	2.0310	5.2
2	2.5000	4.8438	2.7190	4.6875	6.0625	7.4375	8.6250	2.3750	0.8750	0.6250	2.5000	1.3150	2.1890	6.1
2-1/4, 2-7/16	2.7500	5.3438	2.9780	5.1875	6.9375	8.0625	9.2500	2.3750	0.9375	0.6250	2.7500	1.5660	2.5660	9.4

Part Numbers are specified by "PB251HW" and Bore Size.

Example: PB251HW x 1 5/8.

For Load Ratings, see page M-14. For Comparison Charts, see page M-43.

For replacement inserts use YW250 Bearing Inserts, see page M-36.

T-Zerk: 1/4-28 Taper

† DIMENSIONS SHOWN ARE FOR REFERENCE ONLY.

DOWNLOAD AVAILABLE CAD MODELS AT: WWW.HUBCITYINC.COM

Certified prints are available upon request

CALL: (605) 225-0360 • FAX: (605) 225-0567

Hub City IndustrialLine™ Bearing Units

Cast Iron Tapped Base Pillow Blocks

Series TPB220, TPB220W

TPB220 Series

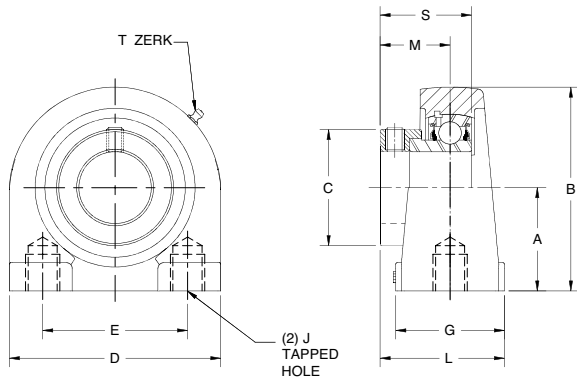

- Relube type. Prelubricated at factory
- Eccentric locking collar
- Self-aligning replaceable bearing
- Nitrile rubber seals with steel trash guard
- Precision bored Cast Iron housing
- Space saving tapped base design

SHAFT SIZE	DIMENSIONS										WT. LBS.
	A	B	C	D	E	G	J – TAPPED HOLES	L	M	S	
1/2, 5/8	1.3120	2.5600	1.1010	2.8700	2.0000	1.5000	3/8-16UNC X .50	1.4000	0.8700	1.1260	0.8
3/4	1.3120	2.5600	1.2730	2.8700	2.0000	1.5000	3/8-16UNC X .50	1.4800	0.9250	1.2200	0.9
7/8, 1	1.4370	2.8000	1.4600	3.0000	2.0000	1.5000	3/8-16UNC X .50	1.5280	0.9250	1.2200	1.4
1-1/8, 1-3/16, 1-1/4s	1.6870	3.3800	1.7100	4.0000	3.0000	1.5000	7/16-14UNC X .63	1.6590	1.0510	1.4060	2.0
1-1/4, 1-3/8, 1-7/16	1.8750	3.7400	2.1480	4.2500	3.2500	1.8900	7/16-14UNC X .78	1.9890	1.1570	1.5310	2.6
1-1/2	1.9370	3.9400	2.3350	4.6100	3.5000	1.8900	1/2-13UNC X .78	2.1670	1.2680	1.7200	3.5
1-5/8, 1-11/16, 1-3/4	2.1250	4.2500	2.4830	5.0000	3.7500	2.0000	1/2-13UNC X .78	2.2620	1.2870	1.7200	4.9
1-7/8, 1-15/16, 2S	2.2500	4.6500	2.7330	5.5000	4.0000	2.0000	5/8-11UNC X .90	2.4010	1.2870	1.8200	5.1
2, 2-3/16	2.2500	4.6500	2.9830	5.5000	4.0000	2.0000	5/8-11UNC X .98	2.3140	1.4390	1.9110	5.2

Part Numbers are specified by "TPB220" and Bore Size. Example: TPB220 x 5/8.
 For Load Ratings, see page M-14. For Comparison Charts, see page M-42.
 For replacement inserts use B220 Bearing Inserts, see page M-35.
 T-Zerk: 1/4-28 Taper

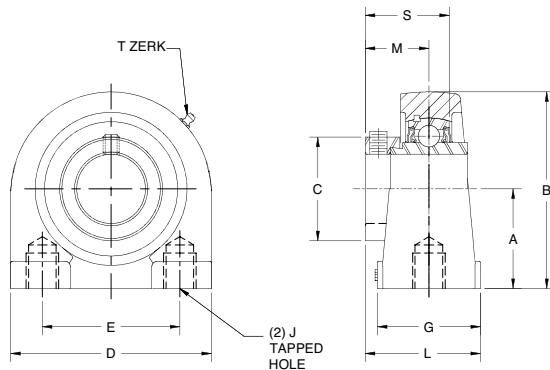

TPB220W Series

- Relube type. Prelubricated at factory
- Eccentric locking collar
- Self-aligning replaceable bearing
- Nitrile rubber seals with steel flingers
- Precision bored Cast Iron housing
- Space saving tapped base design
- Wide inner race

SHAFT SIZE	DIMENSIONS										WT. LBS.
	A	B	C	D	E	G	J – TAPPED HOLES	L	M	S	
7/8, 1	1.4370	2.8000	1.4600	3.0000	2.0000	1.5000	3/8-16UNC X .50	1.5240	1.0590	1.7480	1.5
1-1/8, 1-3/16, 1-1/4s	1.6870	3.3800	1.7100	4.0000	3.0000	1.5000	7/16-14UNC X .63	1.6200	1.1850	1.9060	2.2
1-1/4, 1-3/8, 1-7/16	1.8750	3.7400	2.1480	4.2500	3.2500	1.8900	1/2-13UNC X .78	1.8660	1.2720	2.0120	2.8
1-1/2	1.9370	3.9400	2.3350	4.6100	3.5000	1.8900	1/2-13UNC X .78	1.9270	1.3740	2.2170	3.8
1-5/8, 1-11/16, 1-3/4	2.1250	4.2500	2.4830	5.0000	3.7500	2.0000	1/2-13UNC X .78	2.2470	1.3740	2.2170	5.2
1-7/8, 1-15/16, 2s	2.2500	4.6500	2.7330	5.5000	4.0000	2.0000	5/8-11UNC X .90	2.3200	1.5000	2.4690	5.6
2, 2-3/16	2.2500	4.6500	2.9830	5.5000	4.0000	2.0000	5/8-11UNC X .98	2.3200	1.7170	2.8110	5.7

Part Numbers are specified by "TPB220W" and Bore Size. Example: TPB220W x 5/8.
 For Load Ratings, see page M-14. For Comparison Charts, see page M-42.
 For replacement inserts use YW220 Bearing Inserts, see page M-36.
 T-Zerk: 1/4-28 Taper

DOWNLOAD AVAILABLE CAD MODELS AT: WWW.HUBCITYINC.COM
Certified prints are available upon request

⚠ DIMENSIONS SHOWN ARE FOR REFERENCE ONLY.

Hub City IndustrialLine™ Bearing Units

Cast Iron Tapped Base Pillow Blocks

Series TPB250, TPB250W

TPB250 Series

- Relube type. Prelubricated at factory
- Setscrew locking
- Self-aligning replaceable bearing
- Nitrile rubber seals with steel trash guard
- Precision bored Cast Iron housing
- Space saving tapped base design

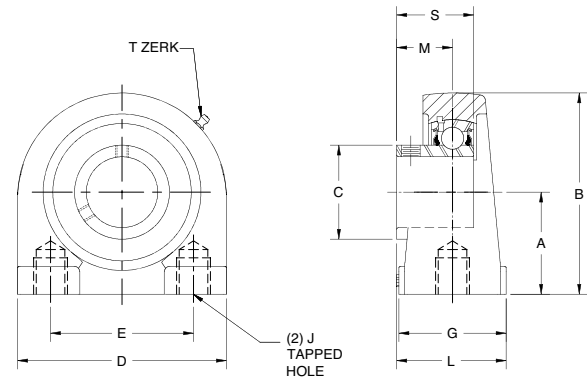

SHAFT SIZE	DIMENSIONS										WT. LBS.
	A	B	C	D	E	G	J – TAPPED HOLES	L	M	S	
1/2, 5/8	1.3120	2.5600	0.9530	2.8700	2.0000	1.5000	3/8-16UNC X .50	1.4000	0.6300	0.8860	0.8
3/4	1.3120	2.5600	1.1100	2.8700	2.0000	1.5000	3/8-16UNC X .50	1.4800	0.7200	1.0040	0.9
7/8, 1	1.4370	2.8000	1.3280	3.0000	2.0000	1.5000	3/8-16UNC X .50	1.5280	0.7680	1.0710	1.4
1-1/8, 1-3/16, 1-1/4s	1.6870	3.3800	1.5630	4.0000	3.0000	1.5000	7/16-14UNC X .63	1.6590	0.8660	1.2200	2.0
1-1/4, 1-3/8, 1-7/16	1.8750	3.7400	1.8150	4.2500	3.2500	1.8900	7/16-14UNC X .78	1.9890	1.0040	1.3780	2.6
1-1/2	1.9370	3.9400	2.0390	4.6100	3.5000	1.8900	1/2-13UNC X .78	2.1670	1.1220	1.5750	3.5
1-5/8, 1-11/16, 1-3/4	2.1250	4.2500	2.2360	5.0000	3.7500	2.0000	1/2-13UNC X .78	2.2620	1.2010	1.6340	4.9
1-7/8, 1-15/16, 2S	2.2500	4.6500	2.4610	5.5000	4.0000	2.0000	5/8-11UNC X .90	2.3010	1.2600	1.6930	5.1
2, 2-3/16	2.2500	4.6500	2.7190	5.5000	4.0000	2.0000	5/8-11UNC X .98	2.3090	1.2800	1.7720	5.2

Part Numbers are specified by "TPB250" and Bore Size. Example: TPB250 x 5/8.

For Load Ratings, see page M-14. For Comparison Charts, see page M-42.

For replacement inserts use B250 Bearing Inserts, see page M-35.

T-Zerk: 1/4-28 Taper

TPB250W Series

- Relube type. Prelubricated at factory
- Setscrew locking
- Self-aligning replaceable bearing
- Nitrile rubber seals with steel flingers
- Precision bored Cast Iron housing
- Space saving tapped base design
- Wide inner race

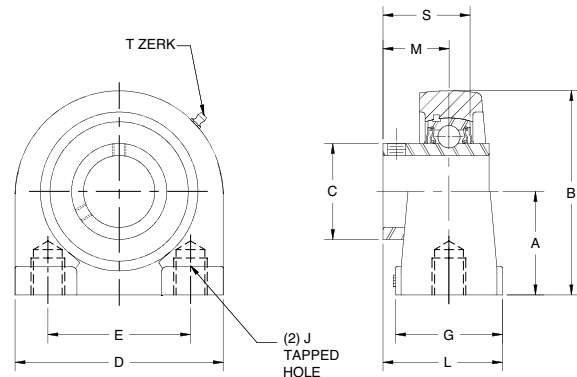

SHAFT SIZE	DIMENSIONS										WT. LBS.
	A	B	C	D	E	G	J – TAPPED HOLES	L	M	S	
5/8	1.3120	2.5600	0.9530	2.8700	2.0000	1.5000	3/8-16UNC X .50	1.4350	0.6260	1.0790	0.8
3/4	1.3120	2.5600	1.1100	2.8700	2.0000	1.5000	3/8-16UNC X .50	1.4600	0.7200	1.2200	1.0
7/8, 1	1.4370	2.8000	1.3280	3.0000	2.0000	1.5000	3/8-16UNC X .50	1.5240	0.7800	1.3430	1.5
1-1/8, 1-3/16, 1-1/4s	1.6870	3.3800	1.5630	4.0000	3.0000	1.5000	7/16-14UNC X .63	1.6200	0.8740	1.5000	2.2
1-1/4, 1-3/8, 1-7/16	1.8750	3.7400	1.8150	4.2500	3.2500	1.8900	1/2-13UNC X .78	1.8700	1.0000	1.6890	2.8
1-1/2	1.9370	3.9400	2.0390	4.6100	3.5000	1.8900	1/2-13UNC X .78	1.9300	1.1890	1.9370	3.8
1-5/8, 1-11/16, 1-3/4	2.1250	4.2500	2.2360	5.0000	3.7500	2.0000	1/2-13UNC X .78	2.2500	1.1890	1.9370	5.2
1-7/8, 1-15/16, 2s	2.2500	4.6500	2.4610	5.5000	4.0000	2.0000	5/8-11UNC X .90	2.3200	1.2830	2.0310	5.6
2, 2-3/16	2.2500	4.6500	2.7190	5.5000	4.0000	2.0000	5/8-11UNC X .98	2.3200	1.3150	2.1890	5.7

Part Numbers are specified by "TPB250W" and Bore Size. Example: TPB250W x 5/8.

For Load Ratings, see page M-14. For Comparison Charts, see page M-42.

For replacement inserts use YW250 Bearing Inserts, see page M-36.

T-Zerk: 1/4-28 Taper

† DIMENSIONS SHOWN ARE FOR REFERENCE ONLY.

DOWNLOAD AVAILABLE CAD MODELS AT: WWW.HUBCITYINC.COM

Certified prints are available upon request

CALL: (605) 225-0360 • FAX: (605) 225-0567

Hub City IndustrialLine™ Bearing Units

Cast Iron Flange Blocks

Series FB220, FB230

FB220 Four-Hole Flange Blocks

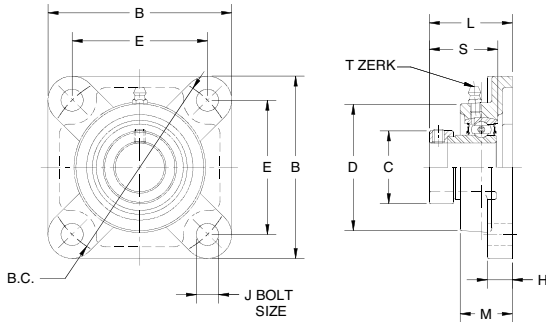

- Relube type. Prelubricated at factory
- Eccentric locking collar
- Self-aligning replaceable bearing
- Nitrile rubber seals with steel trash guard
- Precision bored Cast Iron housing

SHAFT SIZE	DIMENSIONS										WT. LBS.
	B	B.C.	C	D	E	H	J	L	M	S	
1/2, 5/8	3.0000	3.0000	1.1010	2.0900	2.1200	0.4300	0.4500	1.4810	1.0000	1.1260	1.0
3/4	3.3800	3.5630	1.2730	2.3600	2.5200	0.4700	0.4700	1.5350	1.0000	1.2200	1.4
7/8, 1	3.7400	3.8980	1.4600	2.8000	2.7560	0.5500	0.4700	1.5550	1.0600	1.2200	1.8
1-1/8, 1-3/16, 1-1/4s	4.2500	4.6250	1.7100	3.1900	3.2680	0.5500	0.4700	1.7990	1.2200	1.4060	2.6
1-1/4, 1-3/8, 1-7/16	4.6100	5.1250	2.1480	3.6200	3.6220	0.6300	0.5500	1.9450	1.3400	1.5310	4.3
1-1/2	5.1200	5.6770	2.3350	4.0900	4.0160	0.6300	0.6300	2.1930	1.4200	1.7200	5.3
1-5/8, 1-11/16, 1-3/4	5.3900	5.8460	2.4830	4.2500	4.1340	0.7100	0.6300	2.2130	1.5000	1.7200	5.6
1-7/8, 1-15/16, 2S	5.6300	6.1810	2.7330	4.4500	4.3750	0.7100	0.6300	2.1930	1.5700	1.7200	6.5
2, 2-3/16	6.3800	7.2360	2.9830	4.9200	5.1180	0.7800	0.7500	2.4810	1.6900	1.9110	9.1

Part Numbers are specified by "FB220" and Bore Size. Example: FB220 x 1/2.
 For Load Ratings, see page M-14. For Comparison Charts, see page M-42.
 For replacement inserts use B220 Bearing Inserts, see page M-35.
 T-Zerk: 1/4-28 Taper

NOTE: BEARINGS WITH ECCENTRIC LOCKING COLLARS ARE NOT RECOMMENDED FOR USE IN REVERSING APPLICATIONS.

IndustrialLine™ Bearings



FB230 Two-Hole Flange Blocks

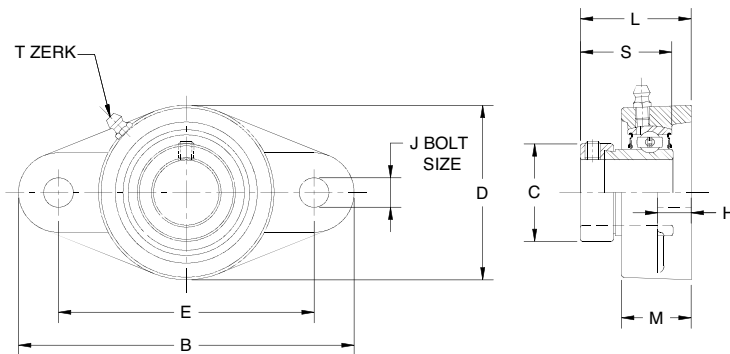

- Relube type. Prelubricated at factory
- Eccentric locking collar
- Self-aligning replaceable bearing
- Nitrile rubber seals with steel trash guard
- Precision bored Cast Iron housing

SHAFT SIZE	DIMENSIONS									WT. LBS.
	B	C	D	E	H	J	L	M	S	
1/2, 5/8	4.4100	1.1010	2.3600	3.0000	0.4300	0.4100	1.5620	0.9800	1.1260	1.0
3/4	4.4100	1.2730	2.3600	3.5310	0.4300	0.4100	1.5080	0.9800	1.2200	1.3
7/8, 1	4.8800	1.4600	2.7600	3.8900	0.5100	0.4900	1.5510	1.0600	1.2200	1.9
1-1/8, 1-3/16, 1-1/4s	5.5500	1.7100	3.2700	4.5940	0.5100	0.4900	1.7950	1.1800	1.4060	2.7
1-1/4, 1-3/8, 1-7/16	6.1400	2.1480	3.7400	5.1250	0.5500	0.5500	1.9490	1.3400	1.5310	3.1
1-1/2	6.7300	2.3350	4.1300	5.6570	0.5500	0.5500	2.1930	1.5000	1.7200	3.6
1-5/8, 1-11/16, 1-3/4	7.0500	2.4830	4.3700	5.8430	0.5500	0.6300	2.2050	1.5700	1.7200	4.3
1-7/8, 1-15/16, 2S	7.4400	2.7330	4.5700	6.1890	0.5500	0.6300	2.2010	1.5700	1.7200	5.3
2, 2-3/16	8.5000	2.9830	5.2400	7.2520	0.8300	0.7100	2.5130	1.7300	1.9110	7.6

Part Numbers are specified by "FB230" and Bore Size. Example: FB230 x 7/8.
 For Load Ratings, see page M-14. For Comparison Charts, see page M-42.
 For replacement inserts use B220 Bearing Inserts, see page M-35.
 T-Zerk: 1/4-28 Taper

NOTE: BEARINGS WITH ECCENTRIC LOCKING COLLARS ARE NOT RECOMMENDED FOR USE IN REVERSING APPLICATIONS.

DOWNLOAD AVAILABLE CAD MODELS AT: WWW.HUBCITYINC.COM
Certified prints are available upon request

† DIMENSIONS SHOWN ARE FOR REFERENCE ONLY.

EMAIL: hubsales@regalbeloit.com • www.hubcityinc.com



Hub City IndustrialLine™ Bearing Units

Hub-Alloy® Flange Blocks

Series FB220HW, FB230HW

FB220HW Four-Hole Flange Blocks

- Relube type. Prelubricated at factory
- Eccentric locking collar
- Self-aligning replaceable bearing
- Nitrile rubber seals with steel flingers
- Precision bored HUB-ALLOY® housing
- Higher strength and greater impact resistance than gray iron for high shock loads
- Wide inner race

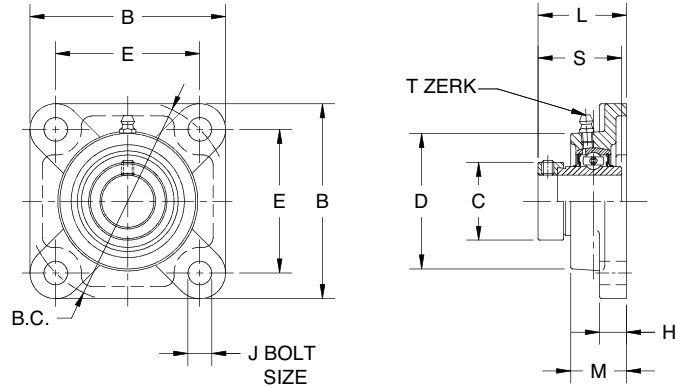

SHAFT SIZE	DIMENSIONS										WT. LBS.
	B	B.C.	C	D	E	H	J	L	M	S	
7/8, 1	3.6600	3.8980	1.4600	2.7500	2.7500	0.5900	0.4530	1.8070	1.1800	1.7480	2.1
1-1/8, 1-3/16, 1-1/4s	4.1800	4.6250	1.7100	3.1500	3.2500	0.6300	0.5120	1.9730	1.2800	1.9060	2.9
1-1/4, 1-3/8, 1-7/16	4.5600	5.1250	2.1480	3.5400	3.6250	0.6700	0.5120	2.0940	1.3800	2.0120	3.9
1-1/2	5.0800	5.6560	2.3350	4.0200	4.0000	0.6700	0.5510	2.3170	1.5400	2.2170	4.9
1-5/8, 1-11/16, 1-3/4	5.3100	5.8340	2.4830	4.2500	4.1250	0.7100	0.6300	2.3170	1.5700	2.2170	5.8
1-7/8, 1-15/16, 2s	5.6300	6.1870	2.7330	4.4900	4.3750	0.7900	0.6300	2.6030	1.7700	2.4690	6.5
2, 2-3/16	6.3800	7.2480	2.9830	4.9600	5.1250	0.8300	0.6700	2.9370	1.9300	2.8110	9.0
2-1/4, 2-7/16	6.8900	7.9550	3.2960	5.3900	5.6250	0.8700	0.6700	3.1810	2.1100	3.0630	10.7

Part Numbers are specified by "FB220HW" and Bore Size. Example: FB220HW x 3/4.
 For Load Ratings, see page M-14. For Comparison Charts, see page M-44.
 For replacement inserts use YW220 Bearing Inserts, see page M-36.
 T-Zerk: 1/4-28 Taper

NOTE: BEARINGS WITH ECCENTRIC LOCKING COLLARS ARE NOT RECOMMENDED FOR USE IN REVERSING APPLICATIONS.

FB230HW Two-Hole Flange Blocks

- Relube type. Prelubricated at factory
- Eccentric locking collar
- Self-aligning replaceable bearing
- Nitrile rubber seals with steel flingers
- Precision bored HUB-ALLOY® housing
- Higher strength and greater impact resistance than gray iron for high shock loads
- Wide inner race

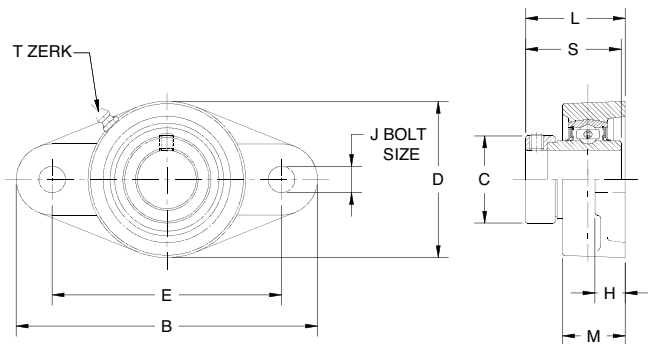

SHAFT SIZE	DIMENSIONS										WT. LBS.
	B	C	D	E	H	J	L	M	S		
7/8, 1	4.8800	1.4600	2.7600	3.8900	0.5100	0.4920	1.8070	1.3200	1.7480	2.0	
1-1/8, 1-3/16, 1-1/4s	5.5500	1.7100	3.2300	4.5940	0.5100	0.4920	1.9960	1.3800	1.9060	2.9	
1-1/4, 1-3/8, 1-7/16	6.1400	2.1480	3.7400	5.1250	0.5900	0.5510	2.1140	1.4700	2.0120	3.3	
1-1/2	6.7700	2.3350	4.1300	5.6570	0.5900	0.5510	2.3110	1.6900	2.2170	3.9	
1-5/8, 1-11/16, 1-3/4	7.0500	2.4830	4.3700	5.8430	0.5900	0.6300	2.3110	1.7500	2.2170	4.6	
1-7/8, 1-15/16, 2s	7.4400	2.7330	4.5600	6.1890	0.5900	0.6300	2.6260	1.8800	2.4690	5.8	
2, 2-3/16	8.5000	2.9830	5.2400	7.2520	0.8300	0.7090	2.9690	2.0000	2.8110	8.1	

Part Numbers are specified by "FB230HW" and Bore Size. Example: FB230HW x 7/8.
 For Load Ratings, see page M-14. For Comparison Charts, see page M-44.
 For replacement inserts use YW220 Bearing Inserts, see page M-36.
 T-Zerk: 1/4-28 Taper

NOTE: BEARINGS WITH ECCENTRIC LOCKING COLLARS ARE NOT RECOMMENDED FOR USE IN REVERSING APPLICATIONS.

1 DIMENSIONS SHOWN ARE FOR REFERENCE ONLY.

DOWNLOAD AVAILABLE CAD MODELS AT: WWW.HUBCITYINC.COM

Certified prints are available upon request

CALL: (605) 225-0360 • FAX: (605) 225-0567

Hub City IndustriaLine™ Bearing Units

Cast Iron Pillow Blocks

Series FB250, FB260

FB250 Four-Hole Flange Blocks

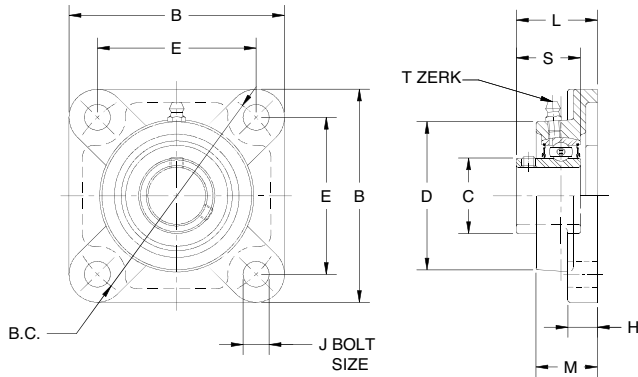

- Relube type. Prelubricated at factory
- Setscrew locking
- Self-aligning replaceable bearing
- Nitrile rubber seals with steel trash guard
- Precision bored Cast Iron housing

SHAFT SIZE	DIMENSIONS										WT. LBS.
	B	B.C.	C	D	E	H	J	L	M	S	
1/2, 5/8	3.0000	3.0000	0.9530	2.0900	2.1260	0.4300	0.4500	1.2400	1.0000	0.8860	1.0
3/4	3.3800	3.5630	1.1100	2.3600	2.5200	0.4700	0.4700	1.3200	1.0000	1.0040	1.4
7/8, 1	3.7400	3.8980	1.3280	2.8000	2.7560	0.5500	0.4700	1.4060	1.0600	1.0710	1.8
1-1/8, 1-3/16, 1-1/4s	4.2500	4.6250	1.5630	3.1900	3.2680	0.5500	0.4700	1.5750	1.2200	1.2200	2.6
1-1/4, 1-3/8, 1-7/16	4.6100	5.1250	1.8150	3.6200	3.6220	0.6300	0.5500	1.7910	1.3400	1.3780	4.2
1-1/2	5.1200	5.6770	2.0390	4.0900	4.0160	0.6300	0.6300	2.0470	1.4200	1.5750	5.3
1-5/8, 1-11/16, 1-3/4	5.3900	5.8460	2.2360	4.2500	4.1340	0.7100	0.6300	2.0990	1.5000	1.6340	5.7
1-7/8, 1-15/16, 2S	5.6300	6.1810	2.4610	4.4500	4.3750	0.7100	0.6300	2.1300	1.5700	1.6930	6.6
2, 2-3/16	6.3800	7.2360	2.7190	4.9200	5.1180	0.7800	0.7500	2.2920	1.6900	1.7720	9.0

Part Numbers are specified by "FB250" and Bore Size. Example: FB250 x 3/4.
 For Load Ratings, see page M-14. For Comparison Charts, see page M-44.
 For replacement inserts use B250 Bearing Inserts, see page M-35.
 T-Zerk: 1/4-28 Taper

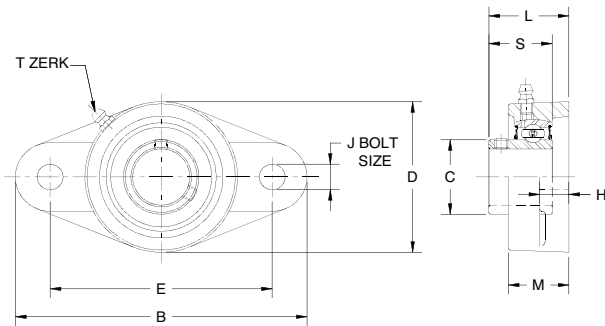

FB260 Two-Hole Flange Blocks

- Relube type. Prelubricated at factory
- Setscrew locking
- Self-aligning replaceable bearing
- Nitrile rubber seals with steel trash guard
- Precision bored Cast Iron housing

SHAFT SIZE	DIMENSIONS									WT. LBS.
	B	C	D	E	H	J	L	M	S	
1/2, 5/8	4.4100	0.9530	2.3600	3.0000	0.4300	0.4100	1.3230	0.9800	0.8860	0.8
3/4	4.4100	1.1100	2.3600	3.5310	0.4300	0.4100	1.3030	0.9800	1.0040	1.0
7/8, 1	4.8800	1.3280	2.7600	3.8900	0.5100	0.4900	1.4100	1.0600	1.0710	1.4
1-1/8, 1-3/16, 1-1/4s	5.5500	1.5630	3.2700	4.5940	0.5100	0.4900	1.6180	1.1800	1.2200	1.9
1-1/4, 1-3/8, 1-7/16	6.1400	1.8150	3.7400	5.1250	0.5500	0.5500	1.8700	1.3400	1.3780	2.9
1-1/2	6.7300	2.0390	4.1300	5.6570	0.5500	0.5500	2.0480	1.5000	1.5750	3.9
1-5/8, 1-11/16, 1-3/4	7.0500	2.2360	4.3700	5.8430	0.5500	0.6300	1.9610	1.5700	1.6340	4.5
1-7/8, 1-15/16, 2S	7.4400	2.4610	4.5700	6.1890	0.5500	0.6300	2.1270	1.5700	1.6930	4.9
2, 2-3/16	8.5000	2.7190	5.2400	7.2520	0.8300	0.7100	2.2020	1.7300	1.7720	6.5

Part Numbers are specified by "FB260" and Bore Size. Example: FB260 x 1-1/8.
 For Load Ratings, see page M-14. For Comparison Charts, see page M-44.
 For replacement inserts use B250 Bearing Inserts, see page M-35.
 T-Zerk: 1/4-28 Taper

DOWNLOAD AVAILABLE CAD MODELS AT: WWW.HUBCITYINC.COM
Certified prints are available upon request

⚠ DIMENSIONS SHOWN ARE FOR REFERENCE ONLY.

Hub City IndustrialLine™ Bearing Units

Hub-Alloy® Flange Blocks

Series FB250HW, FB260HW FB250HW Four-Hole Flange Blocks

- Relube type. Prelubricated at factory
- Setscrew locking
- Self-aligning replaceable bearing
- Nitrile rubber seals with steel flingers
- Precision bored HUB-ALLOY® housing
- Higher strength and greater impact resistance than gray iron for high shock loads
- Wide inner race

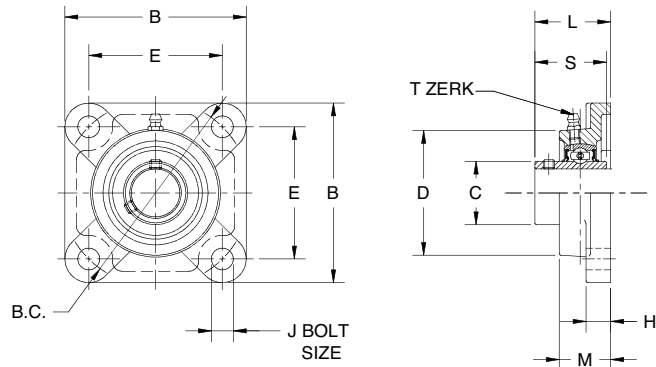

SHAFT SIZE	DIMENSIONS										WT. LBS.
	B	B.C.	C	D	E	H	J	L	M	S	
3/4	3.3800	3.5630	1.1100	2.4000	2.5000	0.5900	0.4530	1.4860	1.1600	1.2200	1.5
7/8, 1	3.6600	3.8980	1.3280	2.7500	2.7500	0.5900	0.4530	1.5270	1.1800	1.3430	1.9
1-1/8, 1-3/16, 1-1/4s	4.1800	4.6250	1.5630	3.1500	3.2500	0.6300	0.5120	1.6610	1.2800	1.5000	2.8
1-1/4, 1-3/8, 1-7/16	4.5600	5.1250	1.8150	3.5400	3.6250	0.6700	0.5120	1.8260	1.3800	1.6890	4.4
1-1/2	5.0800	5.6560	2.0390	4.0200	4.0000	0.6700	0.5510	2.1330	1.5400	1.9370	5.6
1-5/8, 1-11/16, 1-3/4	5.3100	5.8340	2.2360	4.2500	4.1250	0.7100	0.6300	2.1330	1.5700	1.9370	6.0
1-7/8, 1-15/16, 2S	5.6300	6.1870	2.4610	4.4900	4.3750	0.7900	0.6300	2.3860	1.7700	2.0310	7.1
2, 2-3/16	6.3800	7.2480	2.7190	4.9600	5.1250	0.8300	0.6700	2.5350	1.9300	2.1890	9.5
2-1/4, 2-7/16	6.8900	7.9550	2.9780	5.3900	5.6250	0.8700	0.6700	2.8890	2.1100	2.5660	12.4

Part Numbers are specified by "FB250HW" and Bore Size. Example: FB250HW x 3/4.
 For Load Ratings, see page M-14. For Comparison Charts, see page M-44.
 For replacement inserts use YW250 Bearing Inserts, see page M-36.
 T-Zerk: 1/4-28 Taper

FB260HW Two-Hole Flange Blocks

- Relube type. Prelubricated at factory
- Setscrew locking
- Self-aligning replaceable bearing
- Nitrile rubber seals with steel flingers
- Precision bored HUB-ALLOY® housing
- Higher strength and greater impact resistance than gray iron for high shock loads
- Wide inner race

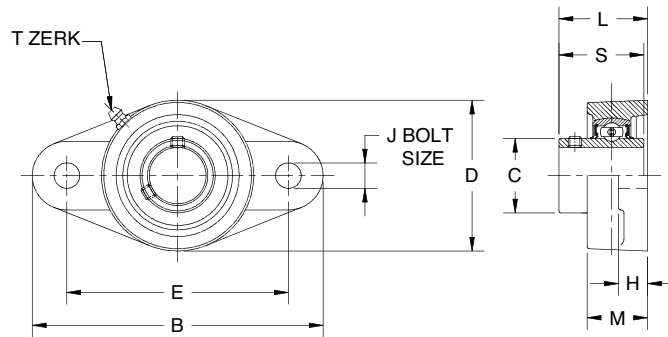

SHAFT SIZE	DIMENSIONS									WT. LBS.
	B	C	D	E	H	J	L	M	S	
3/4	4.4100	1.1100	2.3600	3.5310	0.4300	0.4130	1.4680	1.2600	1.2200	1.1
7/8, 1	4.8800	1.3280	2.7600	3.8900	0.5100	0.4920	1.5270	1.3200	1.3430	1.5
1-1/8, 1-3/16, 1-1/4s	5.5500	1.5630	3.2300	4.5940	0.5100	0.4920	1.6850	1.3800	1.5000	2.1
1-1/4, 1-3/8, 1-7/16	6.1400	1.8150	3.7400	5.1250	0.5900	0.5510	1.8420	1.4700	1.6890	3.1
1-1/2	6.7700	2.0390	4.1300	5.6570	0.5900	0.5510	2.1250	1.6900	1.9370	4.2
1-5/8, 1-11/16, 1-3/4	7.0500	2.2360	4.3700	5.8430	0.5900	0.6300	2.1250	1.7500	1.9370	4.8
1-7/8, 1-15/16, 2S	7.4400	2.4610	4.5600	6.1890	0.5900	0.6300	2.4100	1.8800	2.0310	5.2
2, 2-3/16	8.5000	2.7190	5.2400	7.2520	0.8300	0.7090	2.5670	2.0000	2.1890	7.0

Part Numbers are specified by "FB260HW" and Bore Size. Example: FB260HW x 1-1/8.
 For Load Ratings, see page M-14. For Comparison Charts, see page M-44.
 For replacement inserts use YW250 Bearing Inserts, see page M-36.
 T-Zerk: 1/4-28 Taper

⚠ DIMENSIONS SHOWN ARE FOR REFERENCE ONLY.

DOWNLOAD AVAILABLE CAD MODELS AT: WWW.HUBCITYINC.COM

Certified prints are available upon request

CALL: (605) 225-0360 • FAX: (605) 225-0567

Hub City IndustrialLine™ Bearing Units

Cast Iron Flange Cartridge

Series FC250

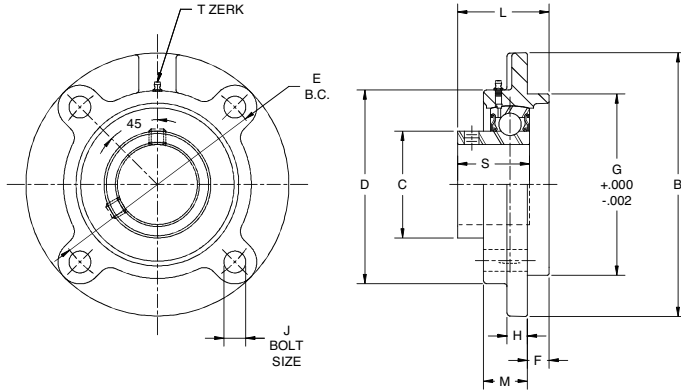

- Relube type. Prelubricated at factory
- Setscrew locking
- Self-aligning replacement bearing
- Nitrile rubber seals with steel trash guard
- Precision bored Cast Iron Housing

SHAFT SIZE	DIMENSIONS											WT. LBS.
	B	C	D	E	F	G	H	J	L	M	S	
1-1/8, 1-3/16, 1-1/4s	4.3700	1.5630	3.2500	3.6220	0.2500	3.0000	0.3700	0.3740	1.5200	0.9400	1.2680	3.3
1-1/4, 1-3/8, 1-7/16	5.0000	1.8150	3.6200	4.1340	0.3700	3.3740	0.3700	0.4720	1.6800	0.8700	1.3150	3.9
1-1/2	5.2400	2.0390	3.8800	4.3700	0.4400	3.6220	0.4300	0.4720	1.9800	1.0200	1.5430	4.1
1-5/8, 1-11/16, 1-3/4	6.1000	2.2360	4.2500	5.1180	0.4700	4.2520	0.4700	0.5510	1.9800	0.8700	1.4170	5.5
1-7/8, 1-15/16, 2s	6.1000	2.4610	4.5000	5.1180	0.4700	4.2520	0.4300	0.5510	2.0700	0.9800	1.5980	6.1
2, 2-3/16	6.3800	2.7190	4.8800	5.3940	0.6300	4.5000	0.5100	0.5510	2.1800	0.9800	1.5900	8.9
2-1/4, 2-7/16	7.0900	2.9780	5.3800	5.9840	0.8700	5.0000	0.6300	0.6300	2.5900	1.0200	1.7200	11.3
2-15/16	8.7400	3.6240	6.3800	7.5000	0.7800	6.3780	0.5600	0.7480	3.0800	1.5350	2.1060	15.4

Part Numbers are specified by "FC250" and Bore Size. Example: FC250 x 1-1/2.

For Load Ratings, see page M-14.

For replacement inserts use B350 Bearing Inserts, see page M-35.

T-Zerk: 1/4-28 Taper

IndustrialLine™ Bearings



Series FR250W

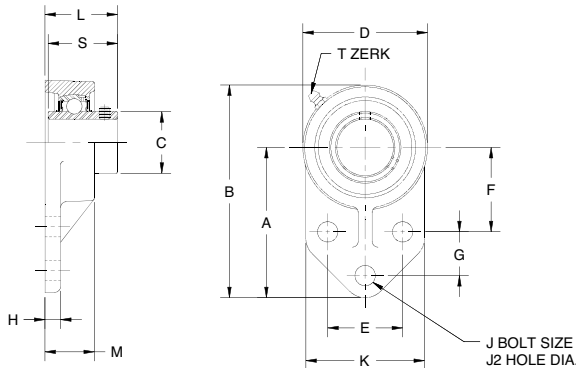

- Cast Iron Housings
- Wide Inner Race
- Self Aligning Replaceable Bearing
- Setscrew Lock Inserts
- Pre-lubricated with Lithium Grease
- Nitrile rubber seals with steel flingers
- Precision Bored Housings

SHAFT SIZE	DIMENSIONS													WT. LBS.	
	A	B	C	D	E	F	G	H	J	J2	K	L	M		S
1/2, 5/8, 3/4	3.0000	4.2500	1.1100	2.5000	1.5000	1.6880	0.8750	0.3100	0.3750	0.3940	2.3800	1.3430	1.0000	1.2200	1.5
7/8, 1	3.3800	4.7500	1.3280	2.7500	1.6250	1.8120	1.1250	0.3800	0.3750	0.3940	2.5000	1.4410	1.1200	1.3430	1.9
1-1/8, 1-3/16, 1-1/4s	3.7500	5.3800	1.5630	3.2500	1.8750	2.0630	1.2500	0.3800	0.3750	0.3940	2.7500	1.6100	1.2500	1.5000	2.2
1-1/4, 1-3/8, 1-7/16	4.2500	6.1200	1.8150	3.7500	2.0000	2.3750	1.2500	0.5000	0.5000	0.5510	3.2500	1.8270	1.4400	1.6890	3.6
1-1/2	4.5000	6.4400	2.0390	3.9400	2.0000	2.3750	1.6250	0.6300	0.5000	0.5510	3.0600	2.0160	1.4100	1.9370	4.6
1-5/8, 1-11/16, 1-3/4	4.7500	6.8700	2.2360	4.1800	2.1250	2.5620	4.6880	0.7200	0.5000	0.5510	3.1300	2.0160	1.5000	1.9370	5.0
1-15/16	5.1800	7.5000	2.4610	4.6500	2.7500	2.9370	1.6250	0.5000	0.5000	0.5510	4.0000	2.1100	1.5000	2.0310	5.7

Dimensions shown are for reference only.

To order, specify type and bore size. Example: FR250W x 1-7/16

T-Zerk: 1/4-28 Taper

Replacement Inserts For 100 and 200 Series Setscrew Lock Use YW250

DOWNLOAD AVAILABLE CAD MODELS AT: WWW.HUBCITYINC.COM

Certified prints are available upon request

EMAIL: hubsales@regalbeloit.com • www.hubcityinc.com



Hub City IndustrialLine™ Bearing Units

Standard Slot Take-Up Units

Series TU220, TU250

TU220 Standard Slot Take-Up Units

- Relube type. Prelubricated at factory
- Eccentric locking collar
- Self-aligning replaceable bearing
- Nitrile rubber seals with steel trash guard
- Precision bored Cast Iron housing

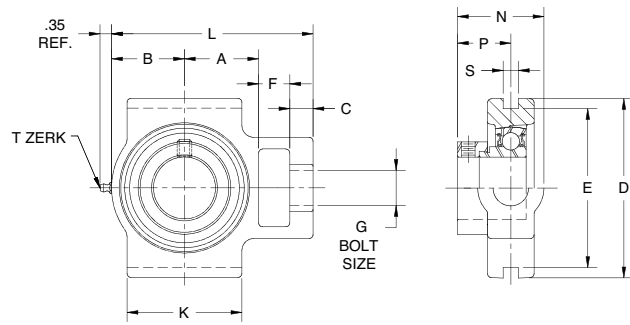

NOTE: BEARINGS WITH ECCENTRIC LOCKING COLLARS ARE NOT RECOMMENDED FOR USE IN REVERSING APPLICATIONS.

SHAFT SIZE	USE WITH FRAME NO. ★	DIMENSIONS													WT. LBS.
		A	B	C	D	E	F	G	J	K	L	N	P	S§	
3/4	3 thru 9T200BC	1.2900	1.2600	0.4000	3.5000	3.0000	0.6300	0.7500	1.8900	1.7300	3.9300	1.6800	0.9450	0.3110	1.6
7/8, 1	3 thru 9T200BC	1.2900	1.3800	0.4000	3.5000	3.0000	0.6300	0.7500	1.8900	1.9300	4.0500	1.6600	0.9250	0.3110	1.9
1-1/8, 1-3/16, 1-1/4S	3 thru 12T200DE	1.6100	1.5800	0.5100	4.0200	3.5040	0.6300	0.8700	2.1300	2.3600	4.6800	1.9000	1.0910	0.3110	2.5
1-1/4, 1-3/8, 1-7/16	3 thru 12T200DE	1.6900	1.7000	0.5100	4.0200	3.5040	0.7500	0.8700	2.1300	2.6400	5.0000	2.0100	1.1970	0.3110	2.9
1-1/2	3 thru 18T200FH	1.8900	1.8500	0.6300	4.4900	4.0000	0.7500	1.1400	2.6400	2.9500	5.4700	2.2700	1.3660	0.3110	4.1
1-5/8, 1-3/4, 1-11/16	3 thru 18T200FH	2.0500	2.0000	0.6300	4.4900	4.0000	0.7500	1.1400	2.6400	3.1100	5.7800	2.2500	1.3460	0.3110	4.6
1-15/16, 2	3 thru 18T200FH	2.2000	2.1300	0.6300	4.4900	4.0000	0.7500	1.1400	2.6400	3.3100	6.0600	2.3300	1.4270	0.3110	4.6
2-3/16, 2-1/4	9 thru 18T200JK	2.3800	2.3300	0.7500	5.7500	5.1260	1.0000	1.3800	3.2700	3.7000	6.8100	2.5550	1.4970	0.3110	8.3
2-7/16	9 thru 18T200JK	2.7000	2.8700	0.7500	5.7500	5.1260	1.0000	1.3800	3.2700	4.0600	7.6700	2.7240	1.6580	0.3110	8.6

Part Numbers are specified by "TU220" and Bore Size. Example: TU220 x 1-1/2.

★ Take-Up Frames shown on page M-33.

§ Take-Up Units with wider slots are shown on page M-30.

T-Zerk: 1/4-28 Taper

For Load Ratings, see page M-14.

For replacement inserts use B220 Bearing Inserts, see page M-35.

TU250 Standard Slot Take-Up Units

- Relube type. Prelubricated at factory
- Setscrew locking
- Self-aligning replaceable bearing
- Nitrile rubber seals with steel trash guard
- Precision bored Cast Iron housing

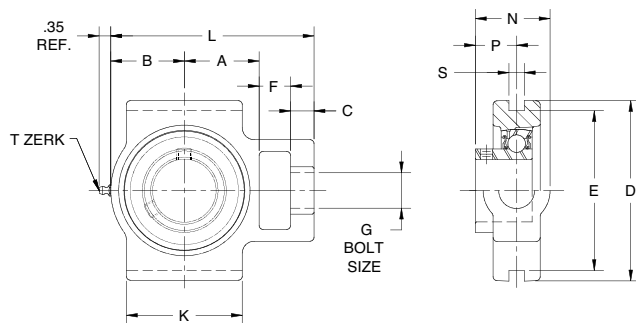

SHAFT SIZE	USE WITH FRAME NO. ★	DIMENSIONS													WT. LBS.
		A	B	C	D	E	F	G	J	K	L	N	P	S§	
3/4	3 thru 9T200BC	1.2900	1.2600	0.4000	3.5000	3.0000	0.6300	0.7500	1.8900	1.7300	3.9300	1.4600	0.7290	0.3110	1.6
7/8, 1	3 thru 9T200BC	1.2900	1.3800	0.4000	3.5000	3.0000	0.6300	0.7500	1.8900	1.9300	4.0500	1.5080	0.7760	0.3110	1.9
1-1/8, 1-3/16, 1-1/4S	3 thru 12T200DE	1.6100	1.5800	0.5100	4.0200	3.5040	0.6300	0.8700	2.1300	2.3600	4.6800	1.7190	0.9050	0.3110	2.5
1-1/4, 1-3/8, 1-7/16	3 thru 12T200DE	1.6900	1.7000	0.5100	4.0200	3.5040	0.7500	0.8700	2.1300	2.6400	5.0000	1.8590	1.0440	0.3110	2.9
1-1/2	3 thru 18T200FH	1.8900	1.8500	0.6300	4.4900	4.0000	0.7500	1.1400	2.6400	2.9500	5.4700	3.4060	1.2200	0.3110	4.1
1-5/8, 1-3/4, 1-11/16	3 thru 18T200FH	2.0500	2.0000	0.6300	4.4900	4.0000	0.7500	1.1400	2.6400	3.1100	5.7800	2.1420	1.2320	0.3110	4.6
1-15/16, 2	3 thru 18T200FH	2.2000	2.1300	0.6300	4.4900	4.0000	0.7500	1.1400	2.6400	3.3100	6.0600	2.1700	1.2630	0.3110	4.6
2-3/16, 2-1/4	9 thru 18T200JK	2.3800	2.3300	0.7500	5.7500	5.1260	1.0000	1.3800	3.2700	3.7000	6.8100	2.3690	1.3080	0.3110	8.3
2-7/16	9 thru 18T200JK	2.7000	2.8700	0.7500	5.7500	5.1260	1.0000	1.3800	3.2700	4.0600	7.6700	2.3850	1.3230	0.3110	8.6

Part Numbers are specified by "TU250" and Bore Size. Example: TU250 x 1-1/2 or TU250N x 1-1/2.

★ Take-Up Frames shown on page M-33.

§ Take-Up Units with wider slots are shown on page M-30.

For Load Ratings, see page M-14.

For replacement inserts use B250 Bearing Inserts, see page M-35.

T-Zerk: 1/4-28 Taper

DOWNLOAD AVAILABLE CAD MODELS AT: WWW.HUBCITYINC.COM

Certified prints are available upon request

CALL: (605) 225-0360 • FAX: (605) 225-0567

Hub City IndustriaLine™ Bearing Units

Hub-Alloy® Standard Slot Take-Up Units

Series TU220W, TU250W

TU220W Standard Slot Take-Up Units

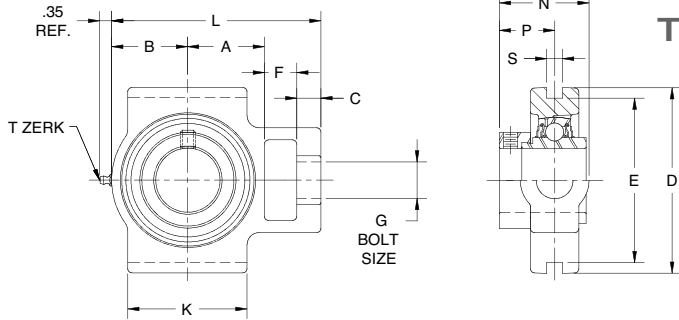

- Relube type. Prelubricated at factory
- Eccentric locking collar
- Self-aligning replaceable bearing
- Nitrile rubber seals with steel flingers
- Precision bored Cast Iron housing
- Wide inner race

NOTE: BEARINGS WITH ECCENTRIC LOCKING COLLARS ARE NOT RECOMMENDED FOR USE IN REVERSING APPLICATIONS.

SHAFT SIZE	USE WITH FRAME NO. ★	DIMENSIONS													WT. LBS.
		A	B	C	D	E	F	G	J	K	L	N	P	S§	
7/8, 1	3 thru 9T200BC	1.2900	1.3800	0.4000	3.5000	3.0000	0.6300	0.7500	1.8900	1.9300	4.0500	1.7900	1.0610	0.3110	1.9
1-1/8, 1-3/16, 1-1/4S	3 thru 12T200DE	1.6100	1.5800	0.5100	4.0200	3.5040	0.6300	0.8700	2.1300	2.3600	4.6800	2.0000	1.1870	0.3110	2.5
1-1/4, 1-3/8, 1-7/16	3 thru 12T200DE	1.6900	1.7000	0.5100	4.0200	3.5040	0.7500	0.8700	2.1300	2.6400	5.0000	2.0760	1.2700	0.3110	2.9
1-1/2	3 thru 18T200FH	1.8900	1.8500	0.6300	4.4900	4.0000	0.7500	1.1400	2.6400	2.9500	5.4700	2.2770	1.3730	0.3110	4.1
1-5/8, 1-3/4, 1-11/16	3 thru 18T200FH	2.0500	2.0000	0.6300	4.4900	4.0000	0.7500	1.1400	2.6400	3.1100	5.7800	2.2770	1.3730	0.3110	4.6
1-15/16, 2	3 thru 18T200FH	2.2000	2.1300	0.6300	4.4900	4.0000	0.7500	1.1400	2.6400	3.3100	6.0600	2.4100	1.5000	0.3110	4.6
2-3/16, 2-1/4	9 thru 18T200JK	2.3800	2.3300	0.7500	5.7500	5.1260	1.0000	1.3800	3.2700	3.7000	6.8100	2.7800	1.7170	0.3110	8.3
2-7/16	9 thru 18T200JK	2.7000	2.8700	0.7500	5.7500	5.1260	1.0000	1.3800	3.2700	4.0600	7.6700	2.9100	1.8440	0.3110	8.6

Part Numbers are specified by "TU220W" and Bore Size. Example: TU220W x 1-1/2.

For Load Ratings, see page M-14.

★ Take-Up Frames shown on page M-33.

Bearing protrudes beyond edge of housing.

§ Take-Up Units with wider slots are shown on page M-31.

For replacement inserts use YW220 Bearing Inserts, see page M-36.

T-Zerk: 1/4-28 Taper

TU250W Standard Slot Take-Up Units

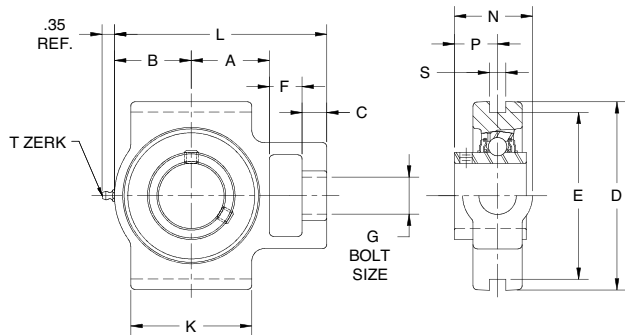

- Relube type. Prelubricated at factory
- Setscrew locking
- Self-aligning replaceable bearing
- Nitrile rubber seals with steel trash guard
- Precision bored Cast Iron housing
- Wide inner race

SHAFT SIZE	USE WITH FRAME NO. ★	DIMENSIONS													WT. LBS.
		A	B	C	D	E	F	G	J	K	L	N	P	S§	
3/4	3 thru 9T200BC	1.2900	1.2600	0.4000	3.5000	3.0000	0.6300	0.7500	1.8900	1.7300	3.9300	1.4500	0.7200	0.3110	1.6
7/8, 1	3 thru 9T200BC	1.2900	1.3800	0.4000	3.5000	3.0000	0.6300	0.7500	1.8900	1.9300	4.0500	1.5040	0.7800	0.3110	1.9
1-1/8, 1-3/16, 1-1/4S	3 thru 12T200DE	1.6100	1.5800	0.5100	4.0200	3.5040	0.6300	0.8700	2.1300	2.3600	4.6800	1.6800	0.8740	0.3110	2.5
1-1/4, 1-3/8, 1-7/16	3 thru 12T200DE	1.6900	1.7000	0.5100	4.0200	3.5040	0.7500	0.8700	2.1300	2.6400	5.0000	1.8100	1.0000	0.3110	2.9
1-1/2	3 thru 18T200FH	1.8900	1.8500	0.6300	4.4900	4.0000	0.7500	1.1400	2.6400	2.9500	5.4700	2.1000	1.1890	0.3110	4.1
1-5/8, 1-3/4, 1-11/16	3 thru 18T200FH	2.0500	2.0000	0.6300	4.4900	4.0000	0.7500	1.1400	2.6400	3.1100	5.7800	2.1000	1.1890	0.3110	4.6
1-15/16, 2	3 thru 18T200FH	2.2000	2.1300	0.6300	4.4900	4.0000	0.7500	1.1400	2.6400	3.3100	6.0600	2.1900	1.2830	0.3110	4.6
2-3/16, 2-1/4	9 thru 18T200JK	2.3800	2.3300	0.7500	5.7500	5.1260	1.0000	1.3800	3.2700	3.7000	6.8100	2.3800	1.3150	0.3110	8.3
2-7/16	9 thru 18T200JK	2.7000	2.8700	0.7500	5.7500	5.1260	1.0000	1.3800	3.2700	4.0600	7.6700	2.6330	1.5660	0.3110	8.6

Part Numbers are specified by "TU250W" and Bore Size. Example: TU250W x 1-1/2.

For Load Ratings, see page M-14.

★ Take-Up Frames shown on page M-33.

For replacement inserts use YW250 Bearing Inserts, see page M-36.

§ Take-Up Units with wider slots are shown on page M-31.

T-Zerk: 1/4-28 Taper

DOWNLOAD AVAILABLE CAD MODELS AT: WWW.HUBCITYINC.COM

Certified prints are available upon request

¶ DIMENSIONS SHOWN ARE FOR REFERENCE ONLY.

Hub City IndustrialLine™ Bearing Units

Wide Slot Take-Up Units

Series WSTU220, WSTU250 WSTU220 Wide Slot Take-Up Units

- Relube type. Prelubricated at factory
- Eccentric locking collar
- Self-aligning replaceable bearing
- Nitrile rubber seals with steel trash guard
- Precision bored Cast Iron housing

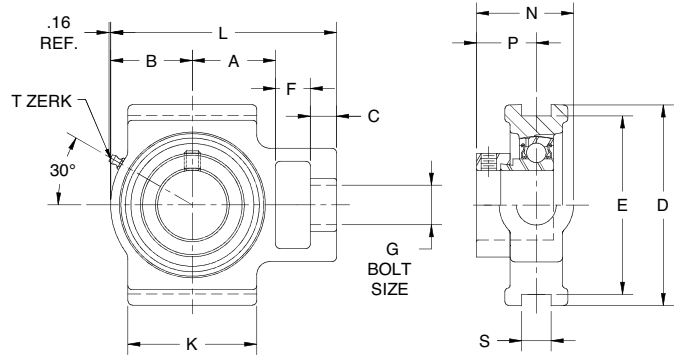

NOTE: BEARINGS WITH ECCENTRIC LOCKING COLLARS ARE NOT RECOMMENDED FOR USE IN REVERSING APPLICATIONS.

SHAFT SIZE	USE WITH FRAME NO. ★	DIMENSIONS														WT. LBS.
		A	B	C	D	E	F	G	J	K	L	N	P	S§		
3/4	3 Thru 9TWS200BC	1.3300	1.3400	0.4000	3.5000	3.0000	0.6300	0.7500	2.0000	2.0000	3.8600	1.5800	0.9450	1.2200	1.6	
7/8, 1	3 Thru 9TWS200BC	1.4100	1.3800	0.4000	3.5000	3.0000	0.6300	0.7500	2.0000	2.0000	3.9800	1.5600	0.9250	1.2200	1.9	
1-1/8, 1-3/16, 1-1/4S	3 Thru 12TWS200DE	1.7300	1.6900	0.4000	4.0200	3.5040	0.6300	0.8700	2.2000	2.2500	4.6100	1.8200	1.0910	1.4060	2.5	
1-1/4, 1-3/8, 1-7/16	3 Thru 12TWS200DE	1.9300	2.0100	0.5100	4.0200	3.5040	0.6300	0.8700	2.5200	2.5200	5.2400	2.6600	1.1970	1.5310	2.9	
1-1/2	3 Thru 18TWS200FH	2.1200	2.1700	0.6300	4.4900	4.0000	0.7500	1.1400	3.2700	3.2700	5.8300	2.3300	1.3660	0.6890	4.1	
1-5/8, 1-3/4, 1-11/16	3 Thru 18TWS200FH	2.0500	2.2400	0.6300	4.4900	4.0000	0.7500	1.1400	3.2700	3.2700	5.8300	2.3100	1.3460	0.6890	4.6	
1-15/16, 2	3 Thru 18TWS200FH	2.1600	2.3300	0.6300	4.4900	4.0000	0.7500	1.1400	3.2700	3.3800	6.0300	2.3900	1.4270	0.6890	4.8	
2-3/16, 2-1/4	9 Thru 18TWS200JK	2.4400	2.5600	0.7500	5.7500	5.1260	0.9800	1.3800	4.0200	3.7400	6.8900	2.7550	1.4970	1.0630	8.3	
2-7/16	9 Thru 18TWS200JK	2.6800	2.9500	0.7500	5.7500	5.1260	1.2600	1.3800	4.0200	4.0200	7.8000	2.9240	1.6580	1.0630	8.8	

Part Numbers are specified by "WSTU220" and Bore Size. Example: WSTU220 x 3/4.

- § Take-Up Units with narrower slots are shown on page M-28.
- For Load Ratings, see page M-14. For Comparison Charts, see page M-45.
- For replacement inserts use B220 Bearing Inserts, see page M-35.
- T-Zerk: 1/4-28 Taper

WSTU250 Wide Slot Take-Up Units

- Relube type. Prelubricated at factory
- Setscrew locking
- Self-aligning replaceable bearing
- Nitrile rubber seals with steel trash guard
- Precision bored Cast Iron housing

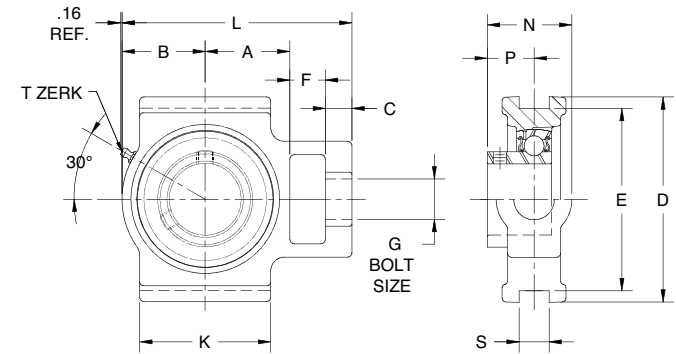

SHAFT SIZE	USE WITH FRAME NO. ★	DIMENSIONS														WT. LBS.
		A	B	C	D	E	F	G	J	K	L	N	P	S§		
3/4	3 Thru 9TWS200BC	1.3300	1.3400	0.4000	3.5000	3.0000	0.6300	0.7500	2.0000	2.0000	3.8600	1.3600	0.7290	1.2200	1.6	
7/8, 1	3 Thru 9TWS200BC	1.4100	1.3800	0.4000	3.5000	3.0000	0.6300	0.7500	2.0000	2.0000	3.9800	1.4080	0.7760	1.2200	1.9	
1-1/8, 1-3/16, 1-1/4S	3 Thru 12TWS200DE	1.7300	1.6900	0.4000	4.0200	3.5040	0.6300	0.8700	2.2000	2.2500	4.6100	1.6390	0.9050	1.4060	2.5	
1-1/4, 1-3/8, 1-7/16	3 Thru 12TWS200DE	1.9300	2.0100	0.5100	4.0200	3.5040	0.6300	0.8700	2.5200	2.5200	5.2400	1.7790	1.0440	1.5310	2.9	
1-1/2	3 Thru 18TWS200FH	2.1200	2.1700	0.6300	4.4900	4.0000	0.7500	1.1400	3.2700	3.2700	5.8300	2.1860	1.2200	0.6890	4.1	
1-5/8, 1-3/4, 1-11/16	3 Thru 18TWS200FH	2.0500	2.2400	0.6300	4.4900	4.0000	0.7500	1.1400	3.2700	3.2700	5.8300	2.1520	1.2320	0.6890	4.6	
1-15/16, 2	3 Thru 18TWS200FH	2.1600	2.3300	0.6300	4.4900	4.0000	0.7500	1.1400	3.2700	3.3800	6.0300	2.1800	1.2630	0.6890	4.8	
2-3/16, 2-1/4	9 Thru 18TWS200JK	2.4400	2.5600	0.7500	5.7500	5.1260	0.9800	1.3800	4.0200	3.7400	6.8900	2.5690	1.3080	1.0630	8.3	
2-7/16	9 Thru 18TWS200JK	2.6800	2.9500	0.7500	5.7500	5.1260	1.2600	1.3800	4.0200	4.0200	7.8000	2.7050	1.3230	1.0630	8.8	

Part Numbers are specified by "WSTU250" and Bore Size. Example: WSTU250 x 3/4.

- § Take-Up Units with narrower slots are shown on page M-28.
- For Load Ratings, see page M-14. For Comparison Charts, see page M-45.
- For replacement inserts use B250 Bearing Inserts, see page M-35.
- T-Zerk: 1/4-28 Taper

† DIMENSIONS SHOWN ARE FOR REFERENCE ONLY.

DOWNLOAD AVAILABLE CAD MODELS AT: WWW.HUBCITYINC.COM

Certified prints are available upon request

CALL: (605) 225-0360 • FAX: (605) 225-0567

Hub City IndustrialLine™ Bearing Units

Wide Slot Take-Up Units

Series WSTU220W, WSTU250W

WSTU220W Wide Slot Take-Up Units

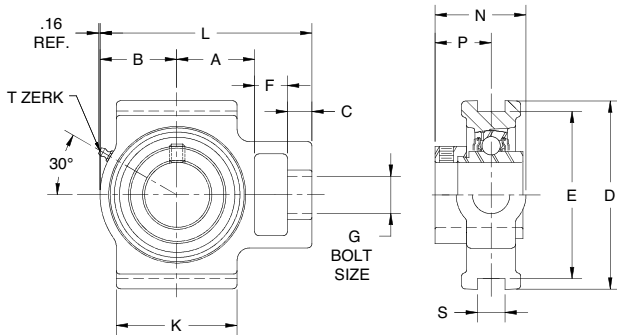

- Relube type. Prelubricated at factory
- Eccentric locking collar
- Self-aligning replaceable bearing
- Nitrile rubber seals with steel flingers
- Precision bored Cast Iron housing

NOTE: BEARINGS WITH ECCENTRIC LOCKING COLLARS ARE NOT RECOMMENDED FOR USE IN REVERSING APPLICATIONS.

SHAFT SIZE	USE WITH FRAME NO. ★	DIMENSIONS													WT. LBS.
		A	B	C	D	E	F	G	J	K	L	N	P	S§	
7/8, 1	3 Thru 9TWS200BC	1.4100	1.3800	0.4000	3.5000	3.0000	0.6300	0.7500	2.0000	2.0000	3.9800	1.6900	1.0610	1.2200	1.9
1-1/8, 1-3/16, 1-1/4S	3 Thru 12TWS200DE	1.7300	1.6900	0.4000	4.0200	3.5040	0.6300	0.8700	2.2000	2.2500	4.6100	1.9200	1.1870	1.4060	2.5
1-1/4, 1-3/8, 1-7/16	3 Thru 12TWS200DE	1.9300	2.0100	0.5100	4.0200	3.5040	0.6300	0.8700	2.5200	2.5200	5.2400	1.9960	1.2700	1.5310	2.9
1-1/2	3 Thru 18TWS200FH	2.1200	2.1700	0.6300	4.4900	4.0000	0.7500	1.1400	3.2700	3.2700	5.8300	2.3370	1.3730	0.6890	4.1
1-5/8, 1-3/4, 1-11/16	3 Thru 18TWS200FH	2.0500	2.2400	0.6300	4.4900	4.0000	0.7500	1.1400	3.2700	3.2700	5.8300	2.3370	1.3730	0.6890	4.6
1-15/16, 2	3 Thru 18TWS200FH	2.1600	2.3300	0.6300	4.4900	4.0000	0.7500	1.1400	3.2700	3.3800	6.0300	2.4700	1.5000	0.6890	4.8
2-3/16, 2-1/4	9 Thru 18TWS200JK	2.4400	2.5600	0.7500	5.7500	5.1260	0.9800	1.3800	4.0200	3.7400	6.8900	2.9800	1.7170	1.0630	8.3
2-7/16	9 Thru 18TWS200JK	2.6800	2.9500	0.7500	5.7500	5.1260	1.2600	1.3800	4.0200	4.0200	7.8000	3.1100	1.8440	1.0630	8.8

Part Numbers are specified by "WSTU220W" and Bore Size. Example: WSTU220W x 3/4.

T-Zerk: 1/4-28 Taper

§ Take-Up Units with narrower slots are shown on page M-29.

For Load Ratings, see page M-14. For Comparison Charts, see page M-45.

For replacement inserts use YW220 Bearing Inserts, see page M-36.

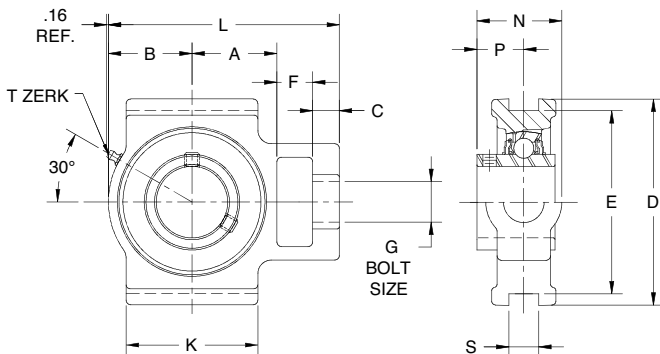

WSTU250W Wide Slot Take-Up Units

- Relube type. Prelubricated at factory
- Setscrew locking
- Self-aligning replaceable bearing
- Nitrile rubber seals with steel flingers
- Precision bored Cast Iron housing

SHAFT SIZE	USE WITH FRAME NO. ★	DIMENSIONS													WT. LBS.
		A	B	C	D	E	F	G	J	K	L	N	P	S§	
3/4	3 Thru 9TWS200BC	1.3300	1.3400	0.4000	3.5000	3.0000	0.6300	0.7500	2.0000	2.0000	3.8600	1.3500	0.7200	1.2200	1.6
7/8, 1	3 Thru 9TWS200BC	1.4100	1.3800	0.4000	3.5000	3.0000	0.6300	0.7500	2.0000	2.0000	3.9800	1.4140	0.7800	1.2200	1.9
1-1/8, 1-3/16, 1-1/4S	3 Thru 12TWS200DE	1.7300	1.6900	0.4000	4.0200	3.5040	0.6300	0.8700	2.2000	2.2500	4.6100	1.6000	0.8740	1.4060	2.5
1-1/4, 1-3/8, 1-7/16	3 Thru 12TWS200DE	1.9300	2.0100	0.5100	4.0200	3.5040	0.6300	0.8700	2.5200	2.5200	5.2400	1.7300	1.0000	1.5310	2.9
1-1/2	3 Thru 18TWS200FH	2.1200	2.1700	0.6300	4.4900	4.0000	0.7500	1.1400	3.2700	3.2700	5.8300	2.1500	1.1890	0.6890	4.1
1-5/8, 1-3/4, 1-11/16	3 Thru 18TWS200FH	2.0500	2.2400	0.6300	4.4900	4.0000	0.7500	1.1400	3.2700	3.2700	5.8300	2.1500	1.1890	0.6890	4.6
1-15/16, 2	3 Thru 18TWS200FH	2.1600	2.3300	0.6300	4.4900	4.0000	0.7500	1.1400	3.2700	3.3800	6.0300	2.2500	1.2830	0.6890	4.8
2-3/16, 2-1/4	9 Thru 18TWS200JK	2.4400	2.5600	0.7500	5.7500	5.1260	0.9800	1.3800	4.0200	3.7400	6.8900	2.5800	1.3150	1.0630	8.3
2-7/16	9 Thru 18TWS200JK	2.6800	2.9500	0.7500	5.7500	5.1260	1.2600	1.3800	4.0200	4.0200	7.8000	2.8230	1.5660	1.0630	8.8

Part Numbers are specified by "WSTU250W" and Bore Size. Example: WSTU250W x 3/4.

T-Zerk: 1/4-28 Taper

§ Take-Up Units with narrower slots are shown on page M-29.

For Load Ratings, see page M-14. For Comparison Charts, see page M-45.

For replacement inserts use B250 Bearing Inserts, see page M-36.

DOWNLOAD AVAILABLE CAD MODELS AT: WWW.HUBCITYINC.COM

† DIMENSIONS SHOWN ARE FOR REFERENCE ONLY.

Certified prints are available upon request

Hub City IndustrialLine™ Bearing Units

Protected Screw Take-Up Frame

- Three bolt base mounting
- Welded steel construction
- Plated adjusting screw

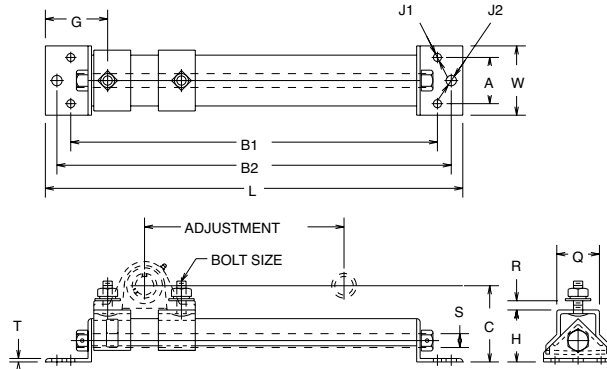

PART NUMBER	SHAFT SIZE	DIMENSIONS													BOLT SIZE	WT. LBS.
		L	W	A	B1	B2	G	H	J1	J2	Q	R	S	T		
6T210BC-3	3/4 - 1	17.1250	3.2500	2.2500	13.8750	15.8750	3.3125	2.3750	0.4375	0.5625	1.7500	0.5625	0.6250	0.1875	0.3750	6.0
9T210BC-3	3/4 - 1	20.1250	3.2500	2.2500	16.8750	18.8750	3.3125	2.3750	0.4375	0.5625	1.7500	0.5625	0.6250	0.1875	0.3750	6.7
6T210DH-3	1-1/16 - 2S	18.1875	3.7500	2.5000	15.4375	16.9375	3.3750	2.8125	0.4375	0.5625	2.3125	0.8750	0.7500	0.1875	0.5000	8.9
9T210DH-3	1-1/16 - 2S	22.6250	3.7500	2.5000	19.8750	21.3750	3.3750	2.8125	0.4375	0.5625	2.3125	0.8750	0.7500	0.1875	0.5000	10.3
12T210DH-3	1-1/16 - 2S	24.1875	3.7500	2.5000	21.4375	22.9375	3.3750	2.8125	0.4375	0.5625	2.3125	0.8750	0.7500	0.1875	0.5000	10.9
18T210DH-3	1-1/16 - 2S	31.6250	3.7500	2.5000	28.8750	30.3750	3.3750	2.8125	0.4375	0.5625	2.3125	0.8750	0.7500	0.1875	0.5000	13.3
12T210JK-3	2 - 2-7/16	28.0000	4.7500	3.0000	24.7500	26.7500	4.0000	3.3125	0.5625	0.6875	2.6250	1.4375	1.0000	0.2500	0.6250	18.3
18T210JK-3	2 - 2-7/16	34.0000	4.7500	3.0000	30.7500	32.7500	4.0000	3.3125	0.5625	0.6875	2.6250	1.4375	1.0000	0.2500	0.6250	21.2

Protected Screw Take-Up Frames are designed for use with:

- PB220, PB221, PB220W, PB221W, PB220HW and PB221HW Pillow Blocks.
- PB250, PB251, PB250W, PB251W, PB250HW and PB251HW Pillow Blocks.
- PB350 and PB350H Pillow Blocks.

* "C" dimension is obtained by adding "H" in the table above to "A" from Pillow Block Dimension tables.

The first digit of the part number represents the nominal adjustment which is possible. Because of the dimensional differences of the various Pillow Blocks, this adjustment varies according to the specifications noted below.

Actual Amount of Adjustment

SHAFT SIZE	FRAME PART NUMBER							
	6T210BC-3	9T210BC-3	6T210DH-3	9T210DH-3	12T210DH-3	18T210DH-3	12T210JK-3	18T210JK-3

WHEN USED WITH 200 SERIES PILLOW BLOCKS

3/4	6.3750	9.3750	—	—	—	—	—	—
13/16 - 1	6.0000	9.0000	—	—	—	—	—	—
1-1/16 - 1-3/16	—	—	6.3750	10.8125	12.3750	19.8125	—	—
1-1/4 - 1-7/16	—	—	6.0000	10.4375	12.0000	19.4375	—	—
1-1/2 - 1-9/16	—	—	5.5625	10.0000	11.5625	19.0000	—	—
1-5/8 - 1-3/4	—	—	5.1875	9.6250	11.1875	18.6250	—	—
1-13/16 - 2S	—	—	4.5625	9.0000	10.5625	18.0000	—	—
2 - 2-3/16	—	—	—	—	—	—	12.7500	18.7500
2-1/4 - 2-7/16	—	—	—	—	—	—	12.0000	18.0000

WHEN USED WITH 350 SERIES PILLOW BLOCKS

1-7/16	—	—	6.6250	11.0625	12.6250	20.0625	—	—
1-1/2 - 1-3/4	—	—	6.1250	10.5625	—	—	14.6875	20.6875
1-15/16 - 2-15/16	—	—	5.6250	10.0625	—	—	14.1875	20.1875
2-3/16 - 2-1/4	—	—	—	—	—	—	13.5625	19.5625
2-7/16 - 2-1/2	—	—	—	—	—	—	12.8125	18.8125

† DIMENSIONS SHOWN ARE FOR REFERENCE ONLY.

DOWNLOAD AVAILABLE CAD MODELS AT: WWW.HUBCITYINC.COM

Certified prints are available upon request

CALL: (605) 225-0360 • FAX: (605) 225-0567

Hub City IndustrialLine™ Bearing Units Take-Up Frames

Series T200 T200 Side Mounting Take-Up Frames

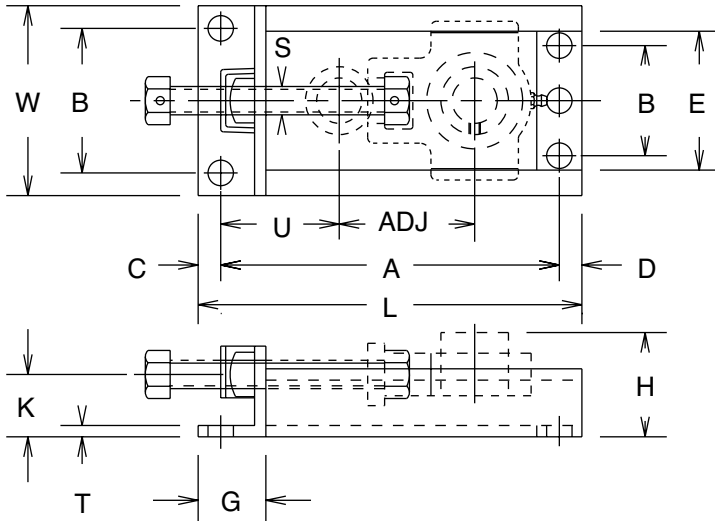

- Welded steel construction
- Plated adjusting screw

IndustrialLine™ Bearings
M

PART NUMBER	SHAFT SIZE RANGE		ADJUST-MENT	DIMENSIONS												BOLT HOLES		WT. LBS.
	FOR "200" SERIES UNITS	FOR "300" SERIES UNITS		L	W	A	B	C	D	E	G	H MAX.	K	S	T	NO.	SIZE	
3T200BC	3/4 - 1		3.0000	8.5000	4.1875	7.5000	3.1875	0.5000	0.5000	3.0625	1.5000	2.2969	1.3750	0.6250	0.2500	3.0000	0.5625	3.6
6T200BC	3/4 - 1		6.0000	11.5000	4.1875	10.5000	3.1875	0.5000	0.5000	3.0625	1.5000	2.2969	1.3750	0.6250	0.2500	3.0000	0.5625	4.4
9T200BC	3/4 - 1		9.0000	14.5000	4.1875	13.5000	3.1875	0.5000	0.5000	3.0625	1.5000	2.2969	1.3750	0.6250	0.2500	3.0000	0.5625	5.5
3T200DE	1-1/16 - 1-7/16		3.0000	9.3750	4.6875	8.3750	3.6875	0.5000	0.5000	3.5625	1.5000	2.5313	1.3750	0.7500	0.2500	3.0000	0.5625	4.3
6T200DE	1-1/16 - 1-7/16		6.0000	12.3750	4.6875	11.3750	3.6875	0.5000	0.5000	3.5625	1.5000	2.5313	1.3750	0.7500	0.2500	3.0000	0.5625	5.3
9T200DE	1-1/16 - 1-7/16		9.0000	15.3750	4.6875	14.3750	3.6875	0.5000	0.5000	3.5625	1.5000	2.5313	1.3750	0.7500	0.2500	3.0000	0.5625	6.3
12T200DE	1-1/16 - 1-7/16		12.0000	18.3750	4.6875	17.3750	3.6875	0.5000	0.5000	3.5625	1.5000	2.5313	1.3750	0.7500	0.2500	3.0000	0.5625	7.4
3T200FH	1-1/2 - 2S	1-7/16 - 1-3/4	3.0000	11.0000	5.1875	9.8750	3.0625	0.5000	0.6250	4.0625	2.0000	2.9375	1.6250	1.0000	0.2500	4.0000	0.5625	6.3
6T200FH	1-1/2 - 2S	1-7/16 - 1-3/4	6.0000	14.0000	5.1875	12.8750	3.0625	0.5000	0.6250	4.0625	2.0000	2.9375	1.6250	1.0000	0.2500	4.0000	0.5625	7.6
9T200FH	1-1/2 - 2S	1-7/16 - 1-3/4	9.0000	17.0000	5.1875	15.8750	3.0625	0.5000	0.6250	4.0625	2.0000	2.9375	1.6250	1.0000	0.2500	4.0000	0.5625	9.1
12T200FH	1-1/2 - 2S	1-7/16 - 1-3/4	12.0000	20.0000	5.1875	18.8750	3.0625	0.5000	0.6250	4.0625	2.0000	2.9375	1.6250	1.0000	0.2500	4.0000	0.5625	10.5
18T200FH	1-1/2 - 2S	1-7/16 - 1-3/4	18.0000	26.0000	5.1875	24.8750	3.0625	0.5000	0.6250	4.0625	2.0000	2.9375	1.6250	1.0000	0.2500	4.0000	0.5625	13.2
9T200JK	2 - 2-7/16	1-15/16 - 2-3/16	9.0000	18.2500	6.3750	16.8750	4.1250	0.6250	0.7500	5.2500	2.0000	3.4375	1.8750	1.2500	0.3125	4.0000	0.6875	13.9
12T200JK	2 - 2-7/16	1-15/16 - 2-3/16	12.0000	21.2500	6.3750	19.8750	4.1250	0.6250	0.7500	5.2500	2.0000	3.4375	1.8750	1.2500	0.3125	4.0000	0.6875	15.0
18T200JK	2 - 2-7/16	1-15/16 - 2-3/16	18.0000	27.2500	6.3750	25.8750	4.1250	0.6250	0.7500	5.2500	2.0000	3.4375	1.8750	1.2500	0.3125	4.0000	0.6875	19.8

These Take-Up Frames are used with TU220, TU250, TU220W and TU250W Take-Up Units shown on pages M-28 and M-29 and with TU350 Take-Up Units shown on page M-40.

*NOTE — "U" may have more than one value, depending on the Take-Up Unit and Frame combination used, therefore determined "U" from frame dimensions "G" minus "C" plus Take-Up Unit dimensions "A", "C" and "F".

Hub City IndustrialLine™ Bearing Units

Take-Up Frames

Series TWS200

TW200 Wide Slot Take-Up Frames

- Welded steel construction
- Plated adjusting screw

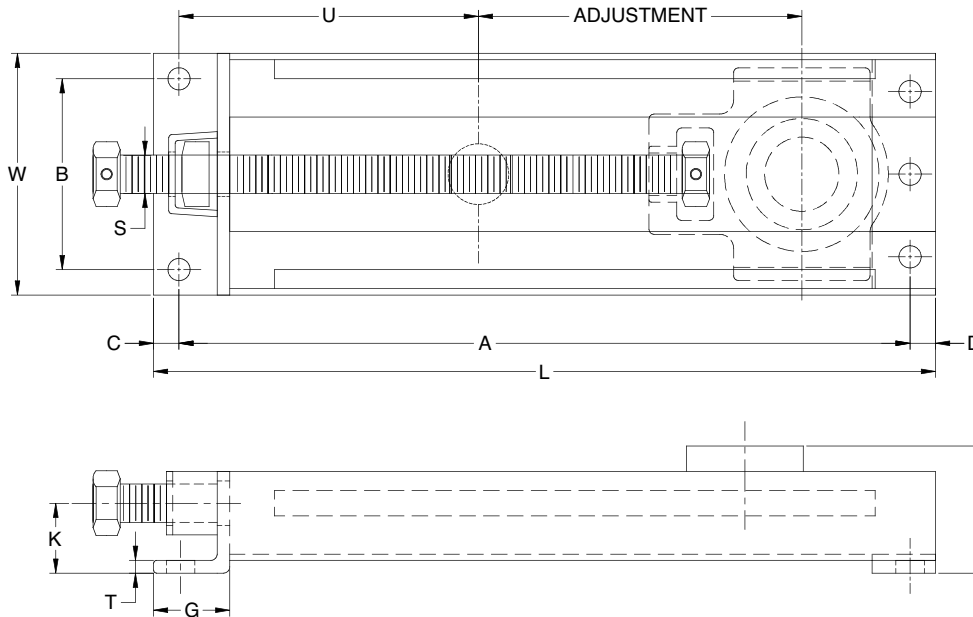

PART NUMBER	SHAFT SIZE RANGE		ADJUSTMENT	DIMENSIONS											BOLT HOLES		WT. LBS.
	FOR "200" SERIES UNITS	FOR "300" SERIES UNITS		L	W	A	B	C	D	G	H MAX.	K	S	T	NO.	SIZE	
1TWS200AC	1/2 - 1		1-1/2	7.000	4.063	6.000	3.188	.500	.500	1.500	2.438	1.375	.625	.250	3	.563	3.3
3TWS200AC	1/2 - 1		3	8.500	4.063	7.500	3.188	.500	.500	1.500	2.438	1.375	.625	.250	3	.563	3.9
6TWS200AC	1/2 - 1		6	11.500	4.063	1.500	3.188	.500	.500	1.500	2.438	1.375	.625	.250	3	.563	5.1
9TWS200AC	1/2 - 1		9	14.500	4.063	13.500	3.188	.500	.500	1.500	2.438	1.375	.625	.250	3	.563	6.2
3TWS200DE	1-1/8 - 1-7/16	1 - 1-1/4	3	9.500	4.688	8.375	3.688	.500	.500	1.500	2.656	1.375	.750	.250	3	.563	5.4
6TWS200DE	1-1/8 - 1-7/16	1 - 1-1/4	6	12.500	4.688	11.375	3.688	.500	.500	1.500	2.656	1.375	.750	.250	3	.563	6.7
9TWS200DE	1-1/8 - 1-7/16	1 - 1-1/4	9	15.500	4.688	14.375	3.688	.500	.500	1.500	2.656	1.375	.750	.250	3	.563	8.1
12TWS200DE	1-1/8 - 1-7/16	1 - 1-1/4	12	18.500	4.688	17.375	3.688	.500	.500	1.500	2.656	1.375	.750	.250	3	.563	9.5
3TWS200FH	1-1/2 - 2S	1-7/16 - 1-3/4	3	11.500	5.063	9.875	3.063	1.00	.625	2.000	3.125	1.625	1.000	.250	4	.563	7.4
6TWS200FH	1-1/2 - 2S	1-7/16 - 1-3/4	6	14.500	5.063	12.875	3.063	1.00	.625	2.000	3.125	1.625	1.000	.250	4	.563	9.1
9TWS200FH	1-1/2 - 2S	1-7/16 - 1-3/4	9	17.500	5.063	15.875	3.063	1.00	.625	2.000	3.125	1.625	1.000	.250	4	.563	10.8
12TWS200FH	1-1/2 - 2S	1-7/16 - 1-3/4	12	20.500	5.063	18.875	3.063	1.00	.625	2.000	3.125	1.625	1.000	.250	4	.563	12.5
18TWS200FH	1-1/2 - 2S	1-7/16 - 1-3/4	18	24.500	5.063	24.875	3.063	1.00	.625	2.000	3.125	1.625	1.000	.250	4	.563	15.9
9TWS200JK	2 - 2-7/16	1-15/16 - 2-3/16	9	18.250	6.313	16.875	4.125	.625	.750	2.000	3.719	1.875	1.250	.313	4	.688	20.0
12TWS200JK	2 - 2-7/16	1-15/16 - 2-3/16	12	21.250	6.313	19.875	4.125	.625	.750	2.000	3.719	1.875	1.250	.313	4	.688	22.8
18TWS200JK	2 - 2-7/16	1-15/16 - 2-3/16	18	27.250	6.313	25.875	4.125	.625	.750	2.000	3.719	1.875	1.250	.313	4	.688	28.2

These Take-Up Frames are used with WSTUS220, WSTUS250, WSTUS220W and WSTU250W Take-Up Units shown on pages M-30 and M-31 and with WSTU350 Take-Up Units shown on page M-41.

*NOTE — "U" may have more than one value, depending on the Take-Up Unit and Frame combination used, therefore determined "U" from frame dimensions "G" minus "C" plus Take-Up Unit dimensions "A", "C" and "F".

11 DIMENSIONS SHOWN ARE FOR REFERENCE ONLY.

DOWNLOAD AVAILABLE CAD MODELS AT: WWW.HUBCITYINC.COM

Certified prints are available upon request

CALL: (605) 225-0360 • FAX: (605) 225-0567

Hub City IndustrialLine™ Bearing Units

Bearing Inserts

Series B220, B250 B220 Bearing Inserts

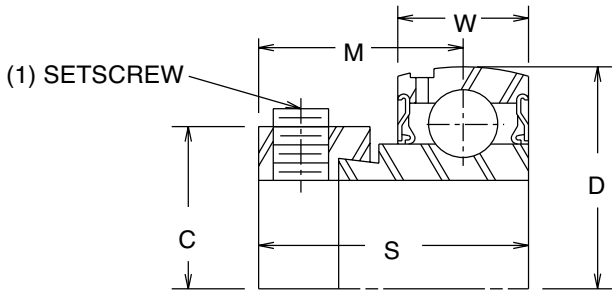

- Spherical outside diameter
- Relube type. Prelubricated at factory
- Molded glass fiber reinforced polyamide retainer
- Nitrile rubber seals with steel trash guard
- Eccentric locking collar

NOTE: BEARINGS WITH ECCENTRIC LOCKING COLLARS ARE NOT RECOMMENDED FOR USE IN REVERSING APPLICATIONS.

SHAFT SIZE	DIMENSIONS						WT. LBS.
	C	D	M	S	W	SETSCREW	
1/2, 5/8	1.1010	1.5748	0.8700	1.1260	0.4720	1/4-28 UNF	0.2
3/4	1.2730	1.8504	0.9250	1.2200	0.5510	1/4-28 UNF	0.3
7/8, 1	1.4600	2.0472	0.9250	1.2200	0.5920	1/4-28 UNF	0.4
1-1/8, 1-3/16, 1-1/4s	1.7100	2.4409	1.0510	1.4060	0.7090	5/16-24 UNF	0.6
1-1/4, 1-3/8, 1-7/16	2.1480	2.8346	1.1570	1.5310	0.7480	3/8-24 UNF	1.0
1-1/2	2.3350	3.1496	1.2680	1.7200	0.8270	3/8-24 UNF	1.3
1-5/8, 1-11/16, 1-3/4	2.4830	3.3465	1.2870	1.7200	0.8660	3/8-24 UNF	1.6
1-7/8, 1-15/16, 2S	2.7330	3.5433	1.2870	1.7200	0.8660	3/8-24 UNF	1.7
2, 2-3/16	2.9830	3.9370	1.4390	1.9110	0.9840	7/16-20 UNF	2.4
2-7/16	3.2960	4.3307	1.5590	2.0910	1.0240	7/16-20 UNF	3.0

Part Numbers are specified by "B220" and Bore Size. Example B220 x 1-1/4.

Used in PB220, PB221 Pillow Blocks; FB220, FB230 Flange Blocks; and TU220, WSTU220 Take-Up Units.

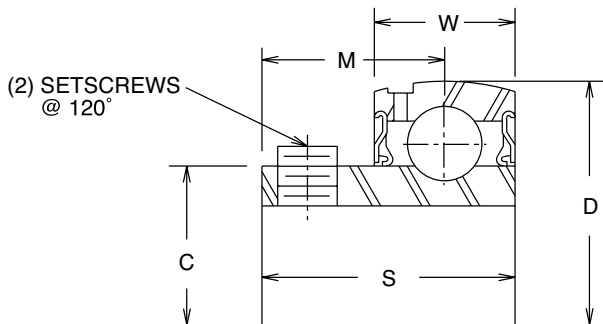

- Spherical outside diameter
- Relube type. Prelubricated at factory
- Molded glass fiber reinforced polyamide retainer
- Nitrile rubber seals with steel trash guard
- Setscrew Locking

B250 Bearing Inserts

SHAFT SIZE	DIMENSIONS						WT. LBS.
	C	D	M	S	W	SETSCREW	
1/2, 5/8	.9530	1.5748	0.6300	0.8860	0.4720	10-32	0.3
3/4	1.1100	1.8504	0.7200	1.0040	0.5510	1/4-28 UNF	0.3
7/8, 15/16, 1	1.3280	2.0472	0.7680	1.0710	0.5920	1/4-28 UNF	0.4
1-1/8, 1-3/16, 1-1/4s	1.5630	2.4409	0.8660	1.2200	0.7090	5/16-24 UNF	0.6
1-1/4, 1-3/8, 1-7/16	1.8150	2.8346	1.0040	1.3780	0.7480	5/16-24 UNF	0.9
1-1/2	2.0390	3.1496	1.1220	1.5750	0.8270	5/16-24 UNF	1.5
1-5/8, 1-11/16, 1-3/4	2.2360	3.3465	1.2010	1.6340	0.8660	5/16-24 UNF	1.8
1-15/16, 2S	2.4610	3.5433	1.2600	1.6930	0.8660	3/8-24 UNF	1.8
2, 2-3/16	2.7190	3.9370	1.2800	1.7720	0.9840	3/8-24 UNF	2.4
2-1/4, 2-7/16	2.9780	4.3307	1.3780	1.9090	1.0240	3/8-24 UNF	2.9
2-15/16	3.6240	5.1181	1.5350	2.1060	1.1420	3/8-24 UNF	4.9

Part Numbers are specified by "B250" and Bore Size. Example B250 x 1-1/4.

Used in PB100, PB100L, PB150, PB150L, PB250, PB251, TPB250 Pillow Blocks; FB100, FB110, FB150, FB160, FB250, FB260 Flange Blocks; and TU250, WSTU250 Take-Up Units.

DOWNLOAD AVAILABLE CAD MODELS AT: WWW.HUBCITYINC.COM

Certified prints are available upon request

† DIMENSIONS SHOWN ARE FOR REFERENCE ONLY.

Hub City IndustrialLine™ Bearing Units

Bearing Inserts

Series YW220, YW250

YW220 Bearing Inserts

- Spherical outside diameter
- Relube type. Prelubricated at factory
- Molded glass fiber reinforced polyamide retainer
- Nitrile rubber seals with steel flingers
- Metal flingers
- Eccentric locking collar
- Wide inner race

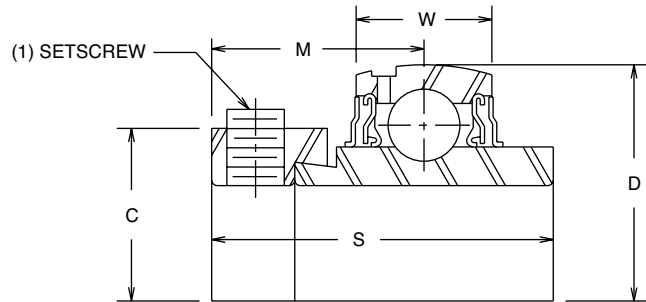

SHAFT SIZE	DIMENSIONS						WT. LBS.
	C	D	M	S	W	SETSCREW	
1	1.4600	2.0472	1.0590	1.7480	0.5910	1/4-28 UNF	0.6
1-3/16	1.7100	2.4409	1.1850	1.9060	0.7090	5/16-24 UNF	0.8
1-1/4, 1-3/8, 1-7/16	2.1480	2.8346	1.2720	2.0120	0.7480	3/8-24 UNF	1.4
1-1/2	2.3350	3.1496	1.3740	2.2170	0.8270	3/8-24 UNF	1.7
1-11/16, 1-3/4	2.4830	3.3465	1.3740	2.2170	0.8660	3/8-24 UNF	1.9
1-15/16	2.7330	3.5433	1.5000	2.4690	0.8660	3/8-24 UNF	2.1
2, 2-3/16	2.9830	3.9370	1.7170	2.8110	0.9840	7/16-20 UNF	3.1
2-7/16	3.2960	4.3307	1.8380	3.0630	1.0240	7/16-20 UNF	4.4

Part Numbers are specified by "YW220" and Bore Size. Example YW220 x 1-1/4.

Used in PB220W, PB221W, PB220HW, PB221HW Pillow Blocks; FB220HW, FB230HW Flange Blocks; and TU220W Take-Up Units.

T-Zerk: 1/4-28 Taper

YW250 Bearing Inserts

- Spherical outside diameter
- Relube type. Prelubricated at factory
- Molded glass fiber reinforced polyamide retainer
- Nitrile rubber seals with steel flingers
- Metal flingers
- Setscrew locking
- Wide inner race

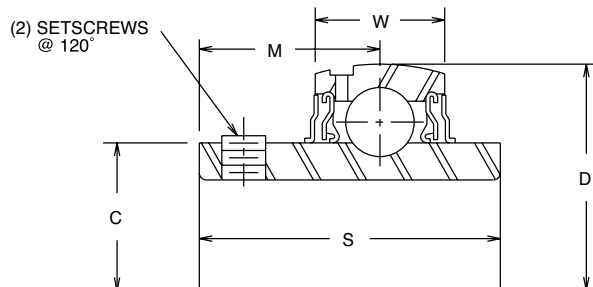

SHAFT SIZE	DIMENSIONS						WT. LBS.
	C	D	M	S	W	SETSCREW	
5/8	0.9530	1.5748	0.6260	1.0790	0.4720	1/4-28 UNF	0.2
3/4	1.1100	1.8504	0.7200	1.2200	0.5510	1/4-28 UNF	0.3
1	1.3280	2.0472	0.7800	1.3430	0.5910	1/4-28 UNF	0.5
1-3/16, 1-1/4S	1.5630	2.4409	0.8740	1.5000	0.7090	1/4-28 UNF	0.7
1-1/4, 1-7/16	1.8150	2.8346	1.0000	1.6890	0.7480	5/16-24 UNF	1.0
1-1/2	2.0390	3.1496	1.1890	1.9370	0.8270	5/16-24 UNF	1.3
1-3/4	2.2360	3.3465	1.1890	1.9370	0.8660	5/16-24 UNF	1.6
1-15/16	2.4610	3.5433	1.2830	2.0310	0.8660	3/8-24 UNF	1.6
2	2.7190	3.9370	1.3150	2.1890	0.9840	3/8-24 UNF	2.5
2-1/4, 2-7/16	2.9780	4.3307	1.5660	2.5660	1.0240	3/8-24 UNF	3.8

Part Numbers are specified by "YW250" and Bore Size. Example YW250 x 1-1/4.

Used in PB250W, PB251W, PB250HW, PB251HW, TPB250W Pillow Blocks; FB250HW, FB260HW Flange Blocks; and TU250W Take-Up Units.

T-Zerk: 1/4-28 Taper

⚠ DIMENSIONS SHOWN ARE FOR REFERENCE ONLY.

DOWNLOAD AVAILABLE CAD MODELS AT: WWW.HUBCITYINC.COM

Certified prints are available upon request

CALL: (605) 225-0360 • FAX: (605) 225-0567

Hub City IndustrialLine™ Bearing Units

Series 350 - Ratings

SHAFT SIZE	BEARING RADIAL LOAD CAPACITY IN POUNDS BASED ON L-10 LIFE OF 500 HOURS AND STEADY LOAD CONDITIONS (2500 HOURS AVERAGE LIFE)							
	BEARING SPEED – REVOLUTIONS PER MINUTE (RPM)							
	100	500	1,000	1,500	2,000	2,500	3,000	3,500
1	3,040	1,780	1,410	1,230	1,120	1,040	980	930
1-3/16	3,980	2,330	1,850	1,610	1,470	1,360	1,280	—
1-7/16	4,790	2,800	2,220	1,940	1,760	1,640	1,540	—
1-1/2	5,180	3,030	2,400	2,100	1,910	1,770	—	—
1-11/16, 1-3/4	5,480	3,200	2,540	2,220	2,020	1,870	—	—
1-15/16, 2	6,800	3,980	3,160	2,760	2,510	—	—	—
2-3/16, 2-1/4	8,250	4,830	3,830	3,350	3,040	—	—	—
2-7/16, 2-1/2	9,710	5,680	4,510	3,940	—	—	—	—
2-11/16	10,330	6,040	4,790	4,190	—	—	—	—
2-15/16, 3	11,370	6,650	5,280	4,610	—	—	—	—
3-7/16, 3-1/2	14,890	8,710	6,910	6,040	—	—	—	—

For ultimate life, snug fit or light press on shaft should be used.

Maximum Recommended Speeds — 1" and smaller 3500 RPM

1-3/16" - 1-7/16" 3000 RPM

1-1/2" - 1-3/4" 2500 RPM

1-15/16" - 2-1/4" 2000 RPM

2-7/16" and larger 1800 RPM

Recommended Operating Temperature Range — 25° to + 225°F.

For applications not covered in the table above, consult factory engineering.

IndustrialLine™ Bearings



TO MODIFY THE ABOVE RATINGS FOR OTHER L-10 LIFE REQUIREMENTS OR FOR SHOCK LOADS MULTIPLY THE ABOVE RATINGS BY THE FACTOR FROM THIS CHART														
MODIFICATION FACTORS FOR L-10 SERVICE LIFE AND LOAD CONDITIONS:														
LOAD CONDITIONS	L-10 LIFE (HOURS)													
	500	700	1,000	1,500	2,000	3,000	4,000	5,000	7,000	10,000	15,000	20,000	30,000	50,000
Steady Load	1.00	.894	.794	.694	.630	.550	.500	.464	.415	.368	.322	.292	.255	.215
Light Shock	.90	.804	.715	.624	.567	.495	.450	.418	.373	.331	.290	.263	.230	.194
Moderate Shock	.70	.626	.556	.485	.441	.385	.350	.325	.290	.258	.225	.205	.179	.151

DOWNLOAD AVAILABLE CAD MODELS AT: WWW.HUBCITYINC.COM

Certified prints are available upon request

EMAIL: hubsales@regalbeloit.com • www.hubcityinc.com



Hub City IndustrialLine™ Bearing Units

Cast Iron Pillow Blocks

Series PB350

- Relube type. Prelubricated at factory
- Setscrew locking
- Self-aligning replaceable bearing
- Nitrile rubber seals with steel trash guard
- Precision bored Cast Iron Housing

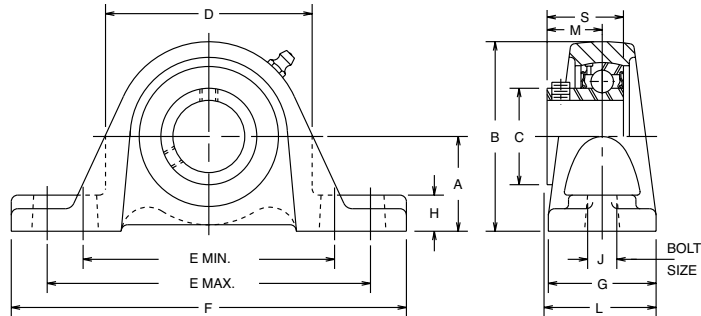

SHAFT SIZE	DIMENSIONS													WT. LBS.
	A	B	C	D	E		F	G	H	J	L	M	S	
					MIN.	MAX.								
1	1.6875	3.2500	1.5630	3.0000	4.2500	5.1250	6.3750	1.7500	0.7500	0.5000	1.7500	0.8660	1.2200	3.3
1-3/16	1.8750	3.6875	1.8150	3.4375	4.6875	5.5000	6.7500	1.8750	0.6875	0.5000	1.9375	1.0040	1.3780	4.4
1-7/16	2.1250	4.1250	2.0390	3.8750	5.1250	5.9375	7.1250	1.8750	0.9375	0.5000	2.0625	1.1220	1.5750	4.9
1-1/2	2.3125	4.4375	2.2360	4.1250	5.7500	6.5000	8.0000	2.0000	1.0000	0.6250	2.2031	1.2010	1.6340	5.6
1-3/4	2.3125	4.5625	2.4610	4.3125	5.8125	6.7500	8.3750	2.0000	0.8750	0.6250	2.2656	1.2600	1.6930	6.7
1-15/16, 2	2.5000	5.0000	2.7190	4.7500	6.4375	7.3750	9.0000	2.2500	0.9375	0.6250	2.4063	1.2800	1.7720	8.5
2-3/16, 2-1/4	2.7500	5.5625	2.9780	5.2500	6.8750	8.0000	9.6250	2.5000	1.1875	0.7500	2.6250	1.3780	1.9090	11.3
2-7/16, 2-1/2	3.0000	6.1250	3.4270	6.0000	7.7500	8.7500	10.5000	2.7500	1.1250	0.7500	2.9375	1.5600	2.0080	15.2
2-11/16	3.5000	6.7500	3.6240	6.2500	8.0000	9.5000	11.2500	3.0000	1.3750	0.8750	3.0313	1.5350	2.1060	17.9
2-15/16, 3	3.5000	7.0000	3.8350	6.7500	8.5000	10.2500	12.0000	3.2500	1.1250	0.8750	3.1563	1.5370	2.1850	19.1
3-7/16, 3-1/2	4.0000	8.0000	4.3940	7.6875	9.6875	12.5625	14.5625	3.5000	1.1250	0.8750	3.3281	1.5750	2.2440	28.4

Part Numbers are specified by "PB350" and Bore Size. Example: PB350 x 2-7/16.

For Load Ratings, see page M-37. For Comparison Charts, see page M-45.

T-Zerk: 1/4-28 Taper

For replacement inserts use B350 Bearing Inserts, see page M-41.

Cast Iron Flange Blocks

Series FB350

- Relube type. Prelubricated at factory
- Setscrew locking
- Self-aligning replacement bearing
- Nitrile rubber seals with steel trash guard
- Precision bored Cast Iron Housing

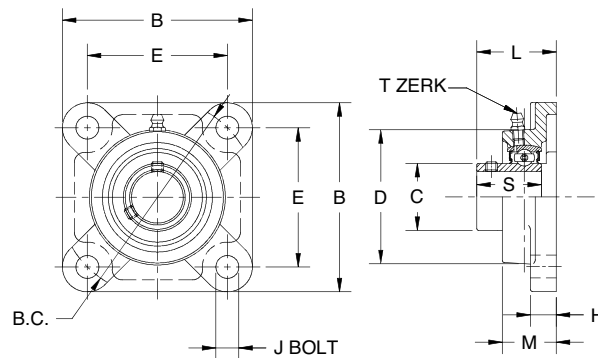

SHAFT SIZE	DIMENSIONS										WT. LBS.
	B	B.C.	C	D	E	H	J	L	M	S	
1	4.2500	4.6250	1.5630	3.1900	3.2680	0.5500	0.4720	1.5750	1.2200	1.2200	3.0
1-3/16	4.6100	5.1250	1.8150	3.6200	3.6220	0.6300	0.5510	1.7520	1.3400	1.3780	4.6
1-7/16	5.1200	5.6770	2.0390	4.0900	4.0160	0.6300	0.6300	1.9490	1.4200	1.5750	5.4
1-1/2	5.3900	5.8460	2.2360	4.2500	4.1340	0.7100	0.6300	2.0670	1.5000	1.6340	5.8
1-11/16, 1-3/4	5.6300	6.1810	2.4610	4.4500	4.3750	0.7100	0.6300	2.1260	1.5700	1.6930	7.0
1-15/16, 2	6.3800	7.2360	2.7190	4.9200	5.1800	0.7800	0.7480	2.2640	1.6900	1.7720	9.2
2-3/16, 2-1/4	6.8800	7.9600	2.9780	5.3100	5.6300	0.7800	0.7480	2.5200	1.8900	1.9090	12.1
2-7/16, 2-1/2	7.3700	8.2960	3.4270	6.0900	5.8660	0.8300	0.7480	2.7960	2.3200	2.0080	15.4
2-11/16	7.7500	8.4630	3.6240	6.3800	5.9840	0.9400	0.9060	2.9920	2.3600	2.1060	18.3
2-15/16, 3	7.7500	8.4630	3.8350	6.7800	5.9840	0.9400	0.9060	3.1100	2.6800	2.1850	19.0
3-7/16, 3-1/2	8.4300	9.5200	4.3940	7.6900	6.7320	0.9400	0.9060	3.1300	2.7500	2.2440	22.2

Part Numbers are specified by "FB350" and Bore Size. Example: FB350 x 2-7/16.

For Load Ratings, see page M-37. For Comparison Charts, see page M-46.

T-Zerk: 1/4-28 Taper

For replacement inserts use B350 Bearing Inserts, see page M-41.

⚠ DIMENSIONS SHOWN ARE FOR REFERENCE ONLY.

DOWNLOAD AVAILABLE CAD MODELS AT: WWW.HUBCITYINC.COM

Certified prints are available upon request

CALL: (605) 225-0360 • FAX: (605) 225-0567

Hub City IndustrialLine™ Bearing Units

Hub-Alloy® Pillow Blocks

Series PB350H

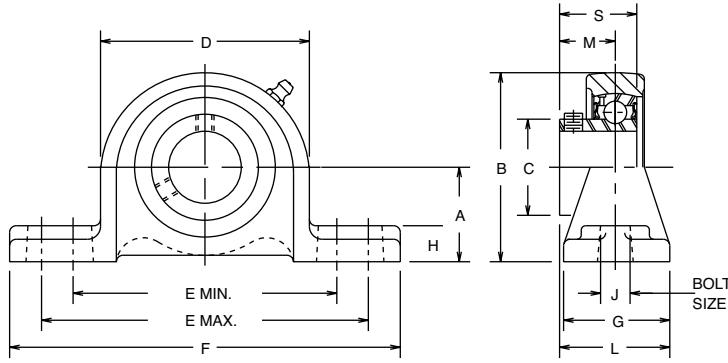

- Relube type. Prelubricated at factory
- Setscrew locking
- Self-aligning replacement bearing
- Nitrile rubber seals with steel trash guard
- Precision bored HUB-ALLOY® housing
- Higher strength and greater impact resistance than gray iron for high shock loads

SHAFT SIZE	DIMENSIONS													WT. LBS.
	A	B	C	D	E		F	G	H	J	L	M	S	
					MIN.	MAX.								
1	1.6875	3.1563	1.5630	2.9375	4.2500	5.1250	6.0625	1.5000	0.6875	0.5000	1.6250	0.8150	1.2200	2.0
1-3/16	1.8750	3.5625	1.8150	3.3750	4.6250	5.5000	6.4375	1.5000	0.6250	0.5000	1.7500	1.0040	1.3780	2.8
1-7/16	2.1250	4.0000	2.0390	3.7500	5.0625	6.3125	7.3750	1.7500	0.6875	0.5000	2.0000	1.1220	1.5750	4.3
1-1/2	2.3125	4.3125	2.2360	4.0000	5.5625	6.6875	7.8750	2.0000	0.8125	0.6250	2.2031	1.2010	1.6340	5.1
1-11/16, 1-3/4	2.3125	4.4375	2.4610	4.2500	5.8125	6.6875	7.8750	2.1250	0.8750	0.6250	2.3281	1.2600	1.6930	5.3
1-15/16, 2	2.5000	4.8438	2.7190	4.6875	6.0625	7.4375	8.6250	2.3750	0.8750	0.6250	2.4688	1.2800	1.7720	6.6
2-3/16, 2-1/4	2.7500	5.3438	2.9780	5.1875	6.6875	7.8125	9.2500	2.6250	0.9375	0.7500	2.6875	1.3780	1.9090	8.6
2-7/16, 2-1/2	3.0000	5.9375	3.4270	5.8750	7.4375	8.5625	10.0000	2.8750	0.9375	0.7500	2.8906	1.4570	2.0080	12.4
2-11/16	3.5000	6.5625	3.6240	6.1250	8.3125	9.6875	11.3125	3.0000	1.0000	0.8750	3.0313	1.5340	2.1060	15.3
2-15/16, 3	3.5000	6.7500	3.8350	6.5000	8.3125	9.6875	11.3125	3.1250	1.0000	0.8750	3.0938	1.5370	2.1850	15.8
3-7/16, 3-1/2	4.0000	7.6875	4.3940	7.3750	9.6875	12.5625	14.1875	3.5000	1.1875	0.8750	3.3281	1.5750	2.2440	23.3

Part Numbers are specified by "PB350H" and Bore Size. Example: PB350H x 2-7/16.

For Load Ratings, see page M-37. For Comparison Charts, see page M-45.

T-Zerk: 1/4-28 Taper

For replacement inserts use B350 Bearing Inserts, see page M-41.

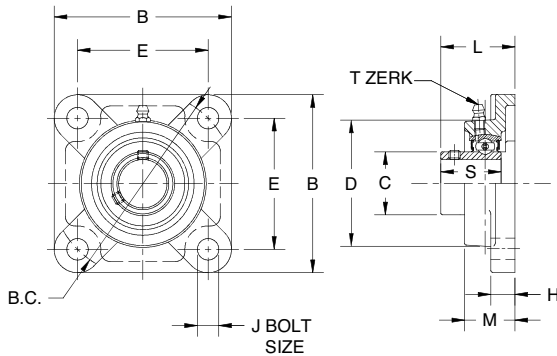

Hub-Alloy® Flange Blocks

Series FB350H

- Relube type. Prelubricated at factory
- Setscrew locking
- Self-aligning replacement bearing
- Nitrile rubber seals with steel trash guard
- Precision bored HUB-ALLOY® housing
- Higher strength and greater impact resistance than gray iron for high shock loads

SHAFT SIZE	DIMENSIONS										WT. LBS.
	B	B.C.	C	D	E	H	J	L	M	S	
1	4.2500	4.5960	1.5630	3.1900	3.2500	0.5100	0.4720	1.3030	1.1800	1.2200	3.0000
1-3/16, 1-1/4	4.6100	5.1250	1.8150	3.6200	3.6250	0.5600	0.6300	1.4370	1.3400	1.3780	4.2000
1-3/8, 1-7/16	5.1200	5.6560	2.0390	4.0900	4.0000	0.5600	0.6300	1.6540	1.5000	1.5750	5.4000
1-1/2	5.3900	5.8340	2.2360	4.2500	4.1250	0.5600	0.7480	1.7520	1.5700	1.6340	5.8000
1-5/8, 1-3/4, 1-11/16	5.6300	6.1870	2.4610	4.4500	4.3750	0.5600	0.7480	1.8510	1.5700	1.6930	7.0000
1-15/16, 2	6.3800	7.2500	2.7190	4.9200	5.1250	0.7900	0.7480	1.9220	1.7300	1.7720	9.2000
2-3/16, 2-1/4	6.8900	7.9540	2.9780	5.3100	5.6250	0.7900	0.7480	2.0510	1.9300	1.9090	12.1000
2-7/16, 2-1/2	7.3600	8.3080	3.4270	6.1000	5.8750	0.8300	0.7480	2.1580	2.3200	2.0080	15.4000
2-11/16	7.7500	8.4850	3.6240	6.3800	6.0000	0.9400	0.9060	2.2520	2.3600	2.1060	18.3000
2-15/16, 3	7.7500	8.4850	3.8350	6.7700	6.0000	0.9400	0.9060	2.4490	2.6800	2.1850	19.0000
3-7/16, 3-1/2	8.4200	9.5460	4.3940	7.6800	6.7500	0.9400	0.9060	2.2550	2.7500	2.2440	22.2000

Part Numbers are specified by "FB350H" and Bore Size. Example: FB350H x 2-7/16.

For Load Ratings, see page M-37. For Comparison Charts, see page M-46.

T-Zerk: 1/4-28 Taper

For replacement inserts use B350 Bearing Inserts, see page M-41.

DOWNLOAD AVAILABLE CAD MODELS AT: WWW.HUBCITYINC.COM

Certified prints are available upon request

† DIMENSIONS SHOWN ARE FOR REFERENCE ONLY.

Hub City IndustriaLine™ Bearing Units

Cast Iron Flange Cartridge

Series FC350

- Relube type. Prelubricated at factory
- Setscrew locking
- Self-aligning replacement bearing
- Nitrile rubber seals with steel trash guard
- Precision bored Cast Iron Housing

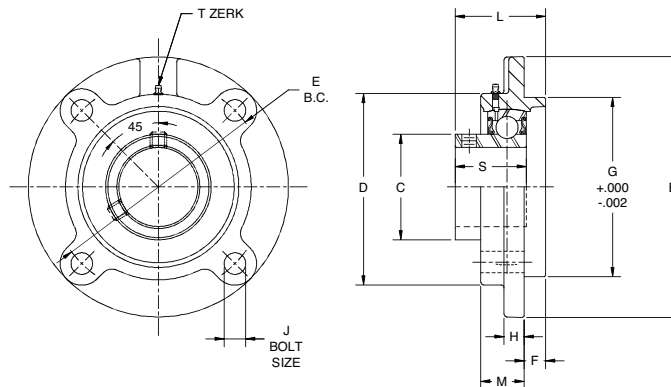

SHAFT SIZE	DIMENSIONS											WT. LBS.
	B	C	D	E	F	G	H	J	L	M	S	
1	4.3700	1.5630	3.2500	3.6220	0.2500	3.0000	0.3700	0.3740	1.5100	0.9400	1.2200	3.3
1-3/16, 1-1/4	5.0000	1.8150	3.6200	4.1340	0.3700	3.3740	0.3700	0.4720	1.6900	0.8700	1.3780	3.3
1-3/8, 1-7/16	5.2800	2.0390	3.8800	4.3700	0.4400	3.6220	0.4300	0.4720	1.9200	0.8700	1.5750	3.9
1-1/2	6.1000	2.2360	4.2500	5.1180	0.4300	4.2520	0.4700	0.5510	2.0000	1.0200	1.6340	4.1
1-5/8, 1-3/4, 1-11/16	6.1000	2.4610	4.5000	5.1180	0.4700	4.2520	0.4300	0.5510	2.0500	0.9800	1.6930	5.5
1-15/16, 2	6.3800	2.7190	4.8800	5.3940	0.6300	4.5000	0.5100	0.5510	2.1500	0.9800	1.7720	6.1
2-3/16, 2-1/4	7.0900	2.9780	5.3800	5.9840	0.8700	5.0000	0.6300	0.6300	2.4100	1.0200	1.9090	8.9
2-7/16, 2-1/2	7.6400	3.4270	6.0000	6.4960	0.7800	5.5000	0.5600	0.6300	2.6700	1.3000	2.0080	11.3
2-11/16	8.7400	3.6240	6.3800	7.5000	0.7800	6.3780	0.5600	0.7480	2.8700	1.4200	2.1060	15.4
2-15/16, 3	8.7400	3.8350	6.6200	7.5000	0.8700	6.3780	0.6300	0.7480	2.8800	1.3800	2.1850	15.2
3-7/16, 3-1/2	10.2400	4.3940	7.5000	8.6220	1.0000	7.3740	0.7500	0.9060	2.9500	1.4200	2.2440	22.5

Part Numbers are specified by "FC350" and Bore Size. Example: FC350 x 1-1/2.

For Load Ratings, see page M-37. For Comparison Charts, see page M-40.

T-Zerk: 1/4-28 Taper

For replacement inserts use B350 Bearing Inserts, see page M-41.

Take-Up Units

Series TU350

- Relube type. Prelubricated at factory
- Setscrew locking
- Self-aligning replacement bearing
- Nitrile rubber seals with steel trash guard
- Precision bored Cast Iron housing

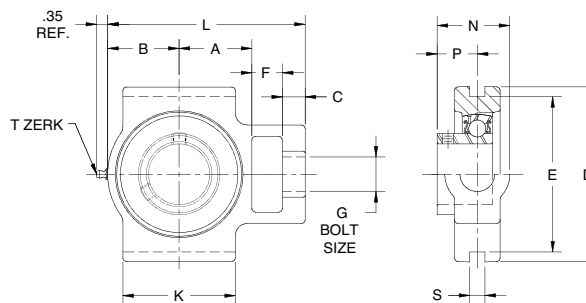

SHAFT SIZE	USE WITH FRAME NO. ★	DIMENSIONS													WT. LBS.
		A	B	C	D	E	F	G	J	K	L	N	P	S	
1-7/16	3 thru 18T200FH	1.8900	1.8500	0.6300	4.4900	4.0000	0.7500	1.1400	2.6400	2.9500	5.4700	1.9000	1.1220	0.3110	4.0
1-1/2	3 thru 18T200FH	2.0500	2.0000	0.6300	4.4900	4.0000	0.7500	1.1400	2.6400	3.1100	5.7800	1.9200	1.2010	0.3110	4.8
1-3/4	3 thru 18T200FH	2.2000	2.1300	0.6300	4.4900	4.0000	0.7500	1.1400	2.6400	3.3100	6.0600	2.0000	1.2600	0.3110	6.8
1-15/16, 2	9 thru 18T200JK	2.3800	2.3300	0.7500	5.7500	5.1260	1.0000	1.3800	3.2700	3.7000	6.8100	2.3500	1.2800	0.3110	9.6
2-3/16, 2-1/4	9 thru 18T200JK	2.3800	2.8700	0.7500	5.7500	5.1260	1.0000	1.3800	3.2700	4.0600	7.6700	2.4500	1.3780	0.3110	12.0

Part Numbers are specified by "TU350" and Bore Size. Example: TU350 x 2-1/4.

For replacement inserts use B350 Bearing Inserts, see page M-41.

T-Zerk: 1/4-28 Taper

★ Take-Up Frames shown on page M-33.

For Load Ratings, see page M-37.

† DIMENSIONS SHOWN ARE FOR REFERENCE ONLY.

DOWNLOAD AVAILABLE CAD MODELS AT: WWW.HUBCITYINC.COM

Certified prints are available upon request

CALL: (605) 225-0360 • FAX: (605) 225-0567

Hub City IndustriaLine™ Bearing Units

Take-Up Units

Series WSTU350

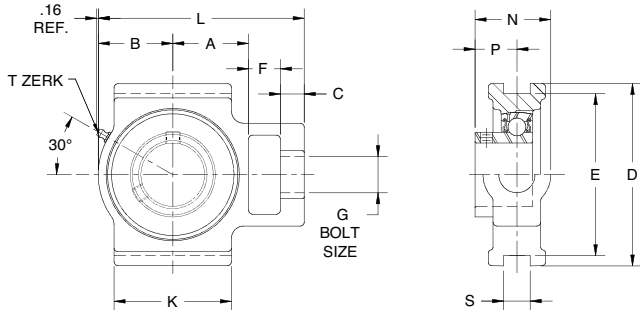

- Relube type. Prelubricated at factory
- Setscrew locking
- Self-aligning replacement bearing
- Nitrile rubber seals with steel trash guard
- Precision bored Cast Iron housing

SHAFT SIZE	USE WITH FRAME NO. ★	DIMENSIONS														WT. LBS.
		A	B	C	D	E	F	G	J	K	L	N	P	S§		
1-7/16	3 Thru 18TWS200FH	2.1200	2.1700	0.6300	4.4900	4.0000	0.7500	1.1400	3.2700	3.2700	5.8300	1.9000	1.1220	0.6890	4.0	
1-1/2	3 Thru 18TWS200FH	2.0500	2.2400	0.6300	4.4900	4.0000	0.7500	1.1400	3.2700	3.2700	5.8300	1.9200	1.2010	0.6890	4.8	
1-5/8, 1-3/4, 1-11/16	3 Thru 18TWS200FH	2.1600	2.3300	0.6300	4.4900	4.0000	0.7500	1.1400	3.2700	3.3800	6.0300	2.0000	1.2600	0.6890	6.8	
1-15/16, 2	9 Thru 18TWS200JK	2.4400	2.5600	0.7500	5.7500	5.1260	0.9800	1.3800	4.0200	3.7400	6.8900	2.3500	1.2800	1.0630	9.6	
2-3/16, 2-1/4	9 Thru 18TWS200JK	2.6800	2.9500	0.7500	5.7500	5.1260	1.2600	1.3800	4.0200	4.0200	7.8000	2.4500	1.3780	1.0630	12.0	
2-7/16, 2-1/2	9 Thru 18TWS200JK	3.3100	3.4200	0.8300	6.5700	5.9450	1.2600	1.6200	4.3700	4.7600	8.9800	2.4500	1.4570	1.0630	16.0	

Part Numbers are specified by "TU350" and Bore Size. Example: TU350 x 2-1/4.
 For replacement inserts use B350 Bearing Inserts, see page M-41.
 T-Zerk: 1/4-28 Taper

★ Take-Up Frames shown on page M-34.
 For Load Ratings, see page M-37.

IndustriaLine™ Bearings



Bearing Inserts

Series B350

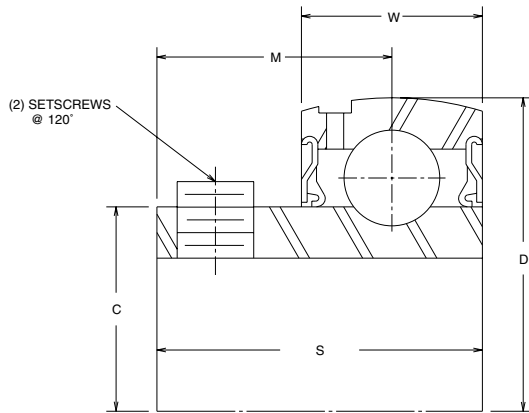

- Spherical outside diameter
- Relube type. Prelubricated at factory
- Molded glass fiber reinforced polyamide retainer
- Nitrile rubber seals with steel trash guard
- Setscrew locking
- Medium duty

SHAFT SIZE	DIMENSIONS						WT. LBS.
	C	D	M	S	W	SETScrew	
1	1.5630	2.4409	0.8660	1.2200	0.7090	5/16-24 UNF	1.0
1-3/16	1.8150	2.8346	1.0040	1.3780	0.7480	5/16-24 UNF	1.3
1-7/16	2.0390	3.1496	1.1220	1.5750	0.8270	5/16-24 UNF	1.6
1-1/2	2.2360	3.3465	1.2010	1.6340	0.8660	5/16-24 UNF	1.9
1-3/4	2.4610	3.5433	1.2600	1.6930	0.8660	3/8-24 UNF	2.2
1-15/16, 2	2.7190	3.9370	1.2800	1.7720	0.9840	3/8-24 UNF	2.6
2-3/16, 2-1/4	2.9780	4.3307	1.3780	1.9090	1.0240	3/8-24 UNF	3.1
2-7/16, 2-1/2	3.4270	4.9213	1.4570	2.0080	1.1020	3/8-24 UNF	5.1
2-11/16	3.6240	5.1181	1.5350	2.1060	1.1420	3/8-24 UNF	5.6
2-15/16, 3	3.8350	5.5118	1.5370	2.1850	1.1810	3/8-24 UNF	6.4
3-7/16, 3-1/2	4.3940	6.2992	1.5750	2.2440	1.3390	3/8-24 UNF	8.5

Part Numbers are specified by "B350" and Bore Size. Example: B350 x 1-1/2.
 Used in PB350, PB350H Pillow Blocks, FB350, FB350H Flange Blocks, FC350 Flange Cartridges and TU350 Take-Up Units.

DOWNLOAD AVAILABLE CAD MODELS AT: WWW.HUBCITYINC.COM
Certified prints are available upon request

† DIMENSIONS SHOWN ARE FOR REFERENCE ONLY.

Hub City IndustrialLine™ Bearing Units

Interchange Comparisons

Series PB120 & PB150

HUB-ALLOY® Pillow Blocks

High Shaft Height

SHAFT SIZE	HUB CITY	BOSTON	BROWNING	SEALMASTER
	PB120 PB150 ^②	XL ^①	VPS-M ^②	LP ^①
1/2	X 1/2	- 1/2	-108	-8
5/8	X 5/8	- 5/8	-110	-10
3/4	X 3/4	- 3/4	-112	-12
7/8	X 7/8	- 7/8	-114	-14
15/16	X 15/16	- 15/16	- 115	-15
1	X 1	-1	-116	-16
1-1/8	X 1-1/8	-1-1/8	-118	-18
1-3/16	X 1-3/16	-1-3/16	-119	-19
1-1/4S	X 1-1/4S	-1-1/4S	-120S	-20R
1-1/4	X 1-1/4	—	—	—
1-5/16	X 1-5/16	-1-5/16	—	—
1-3/8	X 1-3/8	-1-3/8	-122	-22
1-7/16	X 1-7/16	-1-7/16	-123	-23

① Non-Relube – Setscrew Lock

② Relube – Setscrew Lock

Series FB120 & FB150

HUB-ALLOY®

Three-Hole Flange Blocks

SHAFT SIZE	HUB CITY	BOSTON	FAFNIR	BROWNING	PTC	SEALMASTER	DODGE
	FB120 FB150 ^②	XL3 ^①	VFD ^① GVFD ^②	VF3S-M ^②	F-W-U/E ^① F-WG-U/E ^②	LF ^①	SCLF N/L ^① SCLF ^②
1/2	X 1/2	- 1/2	- 1/2	-108	2B08	—	- 1/2
5/8	X 5/8	- 5/8	- 5/8	-110	210	—	- 5/8
3/4	X 3/4	- 3/4	- 3/4	-112	212	-12	- 3/4
7/8	X 7/8	- 7/8	- 7/8	-114	214	-14	- 7/8
15/16	X 15/16	- 15/16	- 15/16	-115	215	-15	- 15/16
1	X 1	-1	-1	-116	216	-16	-1
1-1/8	X 1-1/8	-1-1/8	-1-1/8	-118	218	-18	-1-1/8
1-3/16	X 1-3/16	-1-3/16	-1-3/16	-119	219	-19	-1-3/16
1-1/4S	X 1-1/4S	-1-1/4S	-1-1/4S	-120S	2E20	-20R	-1-1/4, 206
1-1/4	X 1-1/4	—	-1-1/4	—	220	-20	-1-1/4, 207
1-5/16	X 1-5/16	-1-5/16	-1-5/16	—	221	—	-1-5/16
1-3/8	X 1-3/8	-1-3/8	-1-3/8	-122	222	-22	-1-3/8
1-7/16	X 1-7/16	-1-7/16	-1-7/16	-123	223	-23	-1-7/16

① Non-Relube – Setscrew Lock

② Relube – Setscrew Lock

Series FB110, FB130 & FB160

HUB-ALLOY®

Two-Hole Flange Blocks

SHAFT SIZE	HUB CITY	BOSTON	FAFNIR	BROWNING	PTC	SEALMASTER	DODGE
	FB110 ^① FB130 FB160 ^②	XL2 ^②	VFTD ^① GVFTD ^②	VF2S-M ^②	FX-W-U ^③ FX-WG-U ^④	LFT ^①	SCLFT N/L ^① SCLFT ^②
1/2	X 1/2	- 1/2	- 1/2	-108	2B08	-8	- 1/2
5/8	X 5/8	- 5/8	- 5/8	-110	210	-10	- 5/8
3/4	X 3/4	- 3/4	- 3/4	-112	212	-12	- 3/4
7/8	X 7/8	- 7/8	- 7/8	-114	214	-14	- 7/8
15/16	X 15/16	- 15/16	- 15/16	-115	215	-15	- 15/16
1	X 1	-1	-1	-116	216	-16	-1
1-1/8	X 1-1/8	-1-1/8	-1-1/8	-118	218	-18	-1-1/8
1-3/16	X 1-3/16	-1-3/16	-1-3/16	-119	219	-19	-1-3/16
1-1/4S	X 1-1/4S	-1-1/4S	-1-1/4S	-120S	2E20	-20R	-1-1/4, 206
1-1/4	X 1-1/4	—	-1-1/4	—	220	-20	-1-1/4, 207
1-5/16	X 1-5/16	-1-5/16	-1-5/16	—	221	—	-1-5/16
1-3/8	X 1-3/8	-1-3/8	-1-3/8	-122	222	-22	-1-3/8
1-7/16	X 1-7/16	-1-7/16	-1-7/16	-123	223	-23	-1-7/16

① Non-Relube – Setscrew Lock

② Relube – Setscrew Lock

③ Non-Relube – Eccentric Lock

④ Relube – Eccentric Lock

Series TPB220, TPB220W,

TPB250 & TPB250W

Cast Iron Tapped Base

Pillow Blocks

SHAFT SIZE	HUB CITY	BROWNING	SEALMASTER	DODGE
	TPB220 TPB220W TPB250 ^① TPB250W ^①	MTBS ^① VTBS ^①	TB ^① RTB ^①	SCTB ^①
1/2	X 1/2	-208 ^②	-8	- 1/2
5/8	X 5/8	-210	-10	- 5/8
3/4	X 3/4	-212	-12	- 3/4
7/8	X 7/8	-214 ^②	-14	- 7/8
15/16	X 15/16	-215	-15	- 15/16
1	X 1	-216	-16	-1
1-1/8	X 1-1/8	-218 ^②	-18	-1-1/8
1-3/16	X 1-3/16	-219	-19	-1-3/16
1-1/4S	X 1-1/4S	-220S ^②	-20R	-1-1/4, 206
1-1/4	X 1-1/4	-220	-20	-1-1/4, 207
1-5/16	X 1-5/16	—	-21 ^③	-1-5/16
1-3/8	X 1-3/8	-222	-22	-1-3/8
1-7/16	X 1-7/16	-223	-23	-1-7/16
1-1/2	X 1-1/2	-224	-24	—
1-5/8	X 1-5/8	-226 ^②	-26	—
1-11/16	X 1-11/16	-227 ^②	-27	—
1-3/4	X 1-3/4	-228	-28	—
1-15/16	X 1-15/16	-231	-31	—
2S	X 2S	—	-32R	—
2	X 2	-232	—	—
2-3/16	X 2-3/16	—	—	—

① Non-Relube – Setscrew Lock

② Not available in MTBS Series

③ Not available in RTB Series

Interchanges are for comparison purposes; dimensions and ratings may vary.

DOWNLOAD AVAILABLE CAD MODELS AT: WWW.HUBCITYINC.COM

Certified prints are available upon request

CALL: (605) 225-0360 • FAX: (605) 225-0567

Hub City IndustrialLine™ Bearing Units

Interchange Comparisons

Series PB220, PB220W, PB250, PB250W Cast Iron,
PB220HW, PB250HW HUB-ALLOY® Pillow Blocks - Low

SHAFT SIZE	HUB CITY	BOSTON	DODGE	FAFNIR	BROWNING	PTC	SEALMASTER	SKF	MCGILL
	PB220 ① PB250 ② PB220W ① ⑦ PB250W ② ⑦ PB220HW ① ⑦ PB250HW ② ⑦	L ① ⑥ SL ②	SCB ② VSCB ② ⑦ SXR ① SXVB ① ⑦	LAK ① RAK ① TAK ① VAK ①	MPLS ② MPLE ① VPLS ② ④ VPLE ① ④	PL3-U ② PL3-Y ① PL3-W ①	NPL ② RPL ② ⑦ VPL ② ⑦	SYHP ③ ⑧ SYH-X ②	CL-25 ②
1/2	X 1/2	- 1/2	-	- 1/2	-108/208	2B08N/U	-8	-8	- 1/2
5/8	X 5/8	- 5/8	-	- 5/8	-110/210	210N/U	-10	-10	- 5/8
3/4	X 3/4	- 3/4	- 3/4	- 3/4	-112/212	212N/U	-12	-12	- 3/4
7/8	X 7/8	- 7/8	- 7/8	- 7/8	-114/214	214N/U	-14	-14	- 7/8
15/16	X 15/16	- 15/16	- 15/16	- 15/16	-115/215	215N/U	-15	-15	- 15/16
1	X 1	-1	-1	-1	-116/216	216N/U	-16	-100	-1
1-1/8	X 1-1/8	-1-1/8	-1-1/8	-1-1/8	-118/218	218N/E	-18	-102	-1-1/8
1-3/16	X 1-3/16	-1-3/16	-1-3/16	-1-3/16	-119/219	219N/E	-19	-103	-1-3/16
1-1/4S	X 1-1/4S	-1-1/4S	-1-1/4, 206	-	-120S/220S	2E20N/E	-20R	-104A	-1-1/4S
1-1/4	X 1-1/4	-1-1/4	-1-1/4, 207	-1-1/4	-220	220N/E	-20	-104	-1-1/4
1-5/16	X 1-5/16	-1-5/16	-1 5/16	-1-5/16	-	221N/E	-21	-105	-
1-3/8	X 1-3/8	-1-3/8	-1-3/8	-1-3/8	-122/222	222N/E	-22	-106	-1-3/8
1-7/16	X 1-7/16	-1-7/16	-1-7/16	-1-7/16	-123/223	223N/E	-23	-107	-1-7/16
1-1/2	X 1-1/2	-1-1/2	-1-1/2	‡-1-1/2	-224	224N/E	-24	-108	-1-1/2
1-5/8	X 1-5/8	-1-5/8	‡-1-5/8	-1-5/8	-226	226N/U	-26	-110	-1-5/8
1-11/16	X 1-11/16	-1-11/16	-1-11/16	-1-11/16	-227	227N/U	-27	-111	-1-11/16
1-3/4	X 1-3/4	-1-3/4	-1-3/4	-1-3/4	-228	228N/U	-28	-112	-1-3/4
1-7/8	X 1-7/8	-	-	-1-7/8	-	230N/U	-30	-	-
1-15/16	X 1-15/16	-1-15/16	-1-15/16	-1-15/16	-231	231N/U	-31	-115	-1-15/16
2S	X 2S	-	-2, 210	-2S	-	2E32N/U	-2R	-	-2
2	X 2	-2	-	-2	-232	232N	-32	-200	-2L
2-3/16	X 2-3/16	-2-3/16	-2-7/16	-2-3/16	-235	235N	-35	-203	-2-3/16
2 1/4	X 2 1/4	-2-1/4	‡-2-1/4	-2 1/4	-236	236N	-36	-204	-2-1/4
2-7/16	X 2-7/16	-2-7/16	-2-7/16	-2-7/16	-239	239N	-39	-207	-2-7/16
2 15/16	X 2 15/16	-	-	‡-2 15/16	-247	-	-	-215	‡-2-15/16

Series PB221, PB221W, PB251, PB251W Cast Iron,
PB221HW, PB251HW HUB-ALLOY® Pillow Blocks - High

SHAFT SIZE	HUB CITY	BOSTON	DODGE	FAFNIR	BROWNING	PTC	SEALMASTER	SKF	MCGILL
	PB221 ① PB251 ② PB221W ① ⑦ PB251W ② ⑦ PB221HW ① ⑦ PB251HW ② ⑦	H ① ⑥ SH ②	SC ② VSC ② ⑦ SXR ① ⑦ SXV ① ⑦	LAS ① RAS ① RASC ② SAS ② TAS ① VAS ①	MPS ② MPE ① VPS ② ④ VPE ① ④	P3-U ② P3-Y ① P3-W ① ⑤	NP ② RP ② ⑦ VP ② ⑦	SY ② SYP ③ ⑧	C-25 ②
1/2	X 1/2	- 1/2	1/2, 203	- 1/2	-108/208	2B08N/U	-8	-8	- 1/2
5/8	X 5/8	- 5/8	5/8, 203	- 5/8	-110/210	210N/U	-10	-10	- 5/8
3/4	X 3/4	- 3/4	- 3/4	- 3/4	-112/212	212N/U	-12	-12	- 3/4
7/8	X 7/8	- 7/8	- 7/8	- 7/8	-114/214	214N/U	-14	-14	- 7/8
15/16	X 15/16	- 15/16	- 15/16	- 15/16	-115/215	215N/U	-15	-15	- 15/16
1	X 1	-1	-1	-1	-116/216	216N/U	-16	-100	-1
1-1/8	X 1-1/8	-1-1/8	‡-1-1/8	-1-1/8	-118/218	218N/E	-18	-102	-1-1/8
1-3/16	X 1-3/16	-1-3/16	-1-3/16	-1-3/16	-119/219	219N/E	-19	-103	-1-3/16
1-1/4S	X 1-1/4S	-1-1/4S	-1-1/4, 206	-	-120S/220S	2E20N/E	-20R	-104A	-1-1/4S
1-1/4	X 1-1/4	-1-1/4	-1-1/4, 207	-1-1/4	-220	220N/E	-20	-104	-1-1/4
1-5/16	X 1 5/16	-1-5/16	-1-5/16	-1-5/16	-	221N/E	-21	-105	-
1-3/8	X 1-3/8	-1-3/8	-1-3/8	-1-3/8	-122/222	222N/E	-22	-106	-1-3/8
1-7/16	X 1-7/16	-1-7/16	-1-7/16	-1-7/16	-123/223	223N/E	-23	-107	-1-7/16
1-1/2	X 1-1/2	-1-1/2	‡-1-1/2	‡-1-1/2	-224	224N/E	‡-24	-108	-1-1/2
1-5/8	X 1-5/8	-1-5/8	-1-5/8	-1-5/8	-226	226N/U	-26	-110	-1-5/8
1-11/16	X 1-11/16	-1-11/16	-1-11/16	-1-11/16	-227	227N/U	-27	-111	-1-11/16
1-3/4	X 1-3/4	-1-3/4	-1-3/4	-1-3/4	-228	228N/U	-28	-112	-1-3/4
1-7/8	X 1-7/8	-	-	-1-7/8	-	230N/U	-30	-	-
1-15/16	X 1-15/16	-1-15/16	-1 15/16	-1 15/16	-231	231N/U	-31	-115	-1-15/16
2S	X 2S	-	-2, 210	-2S	-	2E32N/U	-2R	-	-2
2	X 2	-2	-2, 211	-2	-232	232N	-32	-200	-2L
2-3/16	X 2-3/16	-2-3/16	-2-3/16	-2-3/16	-235	235N	-35	-203	-2-3/16
2-1/4	X 2-1/4	-2-1/4	-2 1/4, 212	-2-1/4	-236	236N	-36	-204	-2-1/4
2-7/16	X 2-7/16	-2-7/16	-2 7/16	-2-7/16	-239	239N	-39	-207	-2-7/16
2 15/16	X 2-15/16	-	‡-2 15/16	‡-2-15/16	-247	-	-	-215	‡-2-15/16

INTERCHANGES ARE FOR COMPARISON PURPOSES; DIMENSIONS AND RATINGS MAY VARY.

DOWNLOAD AVAILABLE CAD MODELS AT: WWW.HUBCITYINC.COM

Certified prints are available upon request

EMAIL: hubsales@regalbeloit.com • www.hubcityinc.com



Hub City IndustrialLine™ Bearing Units

Interchange Comparisons

Series FB220, FB250 Cast Iron; FB220HW, FB250HW Hub Alloy® 4-Hole Flange Blocks

SHAFT SIZE	HUB CITY	BOSTON	DODGE	FAFNIR	BROWNING	PTC	SEALMASTER	SKF	MCGILL	① Relube – Eccentric Lock ② Relube – Setscrew Lock ③ Non-Relube – Eccentric Lock ④ VF4E and VF4S available in 100 and 200 Series ⑤ U or E Suffix on F3-W only ⑥ 3 thru 12 Prefix on F Series ⑦ Not all sizes available ⑧ 1-7/16 maximum shaft size † Not dimensionally interchangeable
	FB220① FB250② FB220HW①⑦ FB250HW②⑦	F①⑥ SF②	SC4② VSC4②⑦ SXR4①⑦ SXV4①⑦	LCJ① RCJ① RCJC② SCJ② TCJ① VCJ①	MF4S② MF4E① VF-4S②④ VF4E①④	F3-U② F3-Y① F3-W①⑤	SF② RF②⑦ VF②⑦	FYP③⑧ FY② FY-X① FY-TM② FY-WN①⑦	FC4-25②	
1/2	X 1/2	- 1/2	- 1/2, 203	- 1/2	-108/208	2B08N/U	-8	-8	- 1/2	
5/8	X 5/8	- 5/8	- 5/8, 203	- 5/8	-110/210	210N/U	-10	-10	- 5/8	
3/4	X 3/4	- 3/4	- 3/4	- 3/4	-112/212	212N/U	-12	-12	- 3/4	
7/8	X 7/8	- 7/8	- 7/8	- 7/8	-114/214	214N/U	-14	-14	- 7/8	
15/16	X 15/16	- 15/16	- 15/16	- 15/16	-115/215	215N/U	-15	-15	- 15/16	
1	X 1	-1	-1	-1	-116/216	216N/U	-16	-100	-1	
1-1/8	X 1-1/8	-1-1/8	-1-1/8	-1-1/8	-118/218	218N/E	-18	-102	-1-1/8	
1-3/16	X 1-3/16	-1-3/16	-1-3/16	-1-3/16	-119/219	219N/E	-19	-103	-1-3/16	
1-1/4S	X 1-1/4S	-1-1/4S	-1-1/4, 206	—	-120S/220S	2E20N/E	-20R	—	-1-1/4S	
1-1/4	X 1-1/4	-1-1/4	-1-1/4, 207	-1-1/4	-220	220N/E	-20	-104	-1-1/4	
1-5/16	X 1-5/16	-1-5/16	-1-5/16	-1-5/16	—	221N/E	-21	-105	-1-5/16	
1-3/8	X 1-3/8	-1-3/8	-1-3/8	-1-3/8	-122/222	222N/E	-22	-106	-1-3/8	
1-7/16	X 1-7/16	-1-7/16	-1-7/16	-1-7/16	-123/223	223N/E	-23	-107	-1-7/16	
1-1/2	X 1-1/2	-1-1/2	-1-1/2	-1-1/2	-224	224N/E	-24	-108	-1-1/2	
1-5/8	X 1-5/8	-1-5/8	‡-1-5/8	-1-5/8	-226	226N/U	-26	-110	-1-5/8	
1-11/16	X 1-11/16	-1-11/16	-1-11/16	-1-11/16	-227	227N/U	-27	-111	-1-11/16	
1-3/4	X 1-3/4	-1-3/4	-1-3/4	-1-3/4	-228	228N/U	-28	-112	-1-3/4	
1-7/8	X 1-7/8	—	—	-1-7/8	—	230N/U	-30	—	-1-7/8	
1-15/16	X 1-15/16	-1-15/16	-1-15/16	-1-15/16	-231	231N/U	-31	-115	-1-15/16	
2S	X 2S	—	-2, 210	-2S	—	2E32N/U	-32R	—	-2	
2	X 2	-2	-2, 211	-2	-232	2323N	-32	-200	-2L	
2-3/16	X 2-3/16	-2-3/16	-2-3/16	-2-3/16	-235	235N	-35	-203	-2-3/16	
2-1/4	X 2-1/4	-2-1/4	-2-1/4, 212	-2-1/4	-236	236N	-36	-204	-2-1/4	
2-7/16	X 2-7/16	-2-7/16	-2-7/16	-2-7/16	-239	239N	-39	-207	-2-7/16	
2-15/16	X 2-15/16	—	-2-15/16	-2-15/16	-247	—	-47	-215	-2-15/16	

Series FB230, FB260 Cast Iron; FB230HW, FB260HW Hub Alloy® 2-Hole Flange Blocks

SHAFT SIZE	HUB CITY	BOSTON	DODGE	FAFNIR	BROWNING	PTC	SEALMASTER	SKF	MCGILL	① Relube – Eccentric Lock ② Relube – Setscrew Lock ③ Non-Relube – Eccentric Lock ④ VF2E and VF2S available in 100 and 200 Series ⑤ U or E Suffix on F3-W only ⑥ 3 thru 7 Prefix on T Series ⑦ Not all sizes available ⑧ 1-7/16 maximum shaft size † Not dimensionally interchangeable
	FB230① FB260② FB230HW①⑦ FB260HW②⑦	T①⑥ ST②	SC2② VSC2②⑦ SXR2①⑦ SXV2①⑦	LCJT① RCJT① RCJCT② SCJCT② TCJT① VCJT①	MF2S② MF2E① VF2S②④ VF2E①④	FX3-U② FX3-Y① FX3-W①⑤	SFT② RFT②⑦ VFT③⑦	FYPJ-P③⑧ FYTJ-S②⑦ FYTJ-X①⑦ FYT-FM③	FC2-25③	
1/2	X 1/2	- 1/2	- 1/2, 203	- 1/2	-108/208	2B08N/U	-8	-8	- 1/2	
5/8	X 5/8	- 5/8	- 5/8, 203	- 5/8	-110/210	210N/U	-10	-10	- 5/8	
3/4	X 3/4	- 3/4	- 3/4	- 3/4	-112/212	212N/U	-12	-12	- 3/4	
7/8	X 7/8	- 7/8	- 7/8	- 7/8	-114/214	214N/U	-14	-14	- 7/8	
15/16	X 15/16	- 15/16	- 15/16	- 15/16	-115/215	215N/U	-15	-15	- 15/16	
1	X 1	-1	-1	-1	-116/216	216N/U	-16	-100	-1	
1-1/8	X 1-1/8	-1-1/8	-1-1/8	-1-1/8	-118/218	218N/E	-18	-102	-1-1/8	
1-3/16	X 1-3/16	-1-3/16	-1-3/16	-1-3/16	-119/219	219N/E	-19	-103	-1-3/16	
1-1/4S	X 1-1/4S	-1-1/4S	-1-1/4, 206	—	-120S/220S	2E20N/E	-20R	—	-1-1/4S	
1-1/4	X 1-1/4	-1-1/4	-1-1/4, 207	-1-1/4	-220	220N/E	-20	-104	-1-1/4	
1-5/16	X 1-5/16	-1-5/16	-1-5/16	-1-5/16	—	221N/E	-21	-105	-1-5/16	
1-3/8	X 1-3/8	-1-3/8	-1-3/8	-1-3/8	-122/222	222N/E	-22	-106	-1-3/8	
1-7/16	X 1-7/16	-1-7/16	-1-7/16	-1-7/16	-123/223	223N/E	-23	-107	-1-7/16	
1-1/2	X 1-1/2	—	-1-1/2	-1-1/2	-224	224N/E	-24	-108	-1-1/2	
1-5/8	X 1-5/8	—	‡-1-5/8	-1-5/8	-226	226N/U	-26	-110	-1-5/8	
1-11/16	X 1-11/16	—	-1-11/16	-1-11/16	-227	227N/U	-27	-111	-1-11/16	
1-3/4	X 1-3/4	—	-1-3/4	-1-3/4	-228	228N/U	-28	-112	-1-3/4	
1-7/8	X 1-7/8	—	—	-1-7/8	—	230N/U	-30	—	-1-7/8	
1-15/16	X 1-15/16	—	-1-15/16	-1-15/16	-231	231N/U	-31	-115	-1-15/16	
2S	X 2S	—	-2	-2S	—	2E32N/U	-32R	—	-2	
2	X 2	—	—	-2	-232	232N	-32	-200	-2L	
2-3/16	X 2-3/16	—	—	-2-3/16	-235	235N	-35	-203	-2-3/16	
2-1/4	X 2-1/4	-2-1/4	—	—	—	—	—	—	—	
2-7/16	X 2-7/16	-2-7/16	—	—	—	—	—	—	—	

INTERCHANGES ARE FOR COMPARISON PURPOSES; DIMENSIONS AND RATINGS MAY VARY.

DOWNLOAD AVAILABLE CAD MODELS AT: WWW.HUBCITYINC.COM

Certified prints are available upon request

CALL: (605) 225-0360 • FAX: (605) 225-0567

Hub City IndustrialLine™ Bearing Units

Interchange Comparisons

Series WSTU220, WSTU250 HUB-ALLOY® Wide Slot Take-Up Units

SHAFT SIZE	HUB CITY		DODGE	FAFNIR	BROWNING		PTC	SEALMASTER		SKF	
	WSTU220 ^①	WSTU250 ^②	SC ^② SXR ^{①②} SXV ^{①②}	RTU ^①	VTWE ^①	MTWS ^② VTWS ^②	TH3-U ^②	ST ^②	RT ^②	TB ^②	TBX ^①
3/4	X 3/4	X 3/4	- 3/4	- 3/4	-212	-212	212N	—	-12	-12	-12
7/8	X 7/8	X 7/8	-7/8	-7/8	-214	-214	214N	—	-14	-14	-14
15/16	X 15/16	X 15/16	-15/16	-15/16	-215	-215	215N	-15	-15	-15	-15
1	X 1	X 1	-1	-1	-216	-216	216N	-16	-16	-100	-100
1-1/8	X 1-1/8	X 1-1/8	-1-1/8	-1-1/8	-218	-218	218N	—	-18	-102	-102
1-3/16	X 1-3/16	X 1-3/16	-1-3/16	-1-3/16	-219	-219	219N	-19	-19	-103	-103
1-1/4S	X 1-1/4S	X 1-1/4S	-1-1/4, 206	—	—	—	2E20N	-20R	-20R	—	—
1-1/4	X 1-1/4	X 1-1/4	-1-1/4, 207	-1-1/4	-220	-220	220N	-20	-20	-104	-104
1-5/16	X 1-5/16	X 1-5/16	-1-5/16	-1-5/16	—	—	221N	—	—	-105	-105
1-3/8	X 1-3/8	X 1-3/8	-1-3/8	-1-3/8	-222	-222	222N	—	-22	-106	-106
1-7/16	X 1-7/16	X 1-7/16	-1-7/16	-1-7/16	-223	-223	223N	-23	-23	-107	-107
1-1/2	X 1-1/2	X 1-1/2	-1-1/2	-1-1/2	-224	-224	224N	-24	-24	-108	-108
1-5/8	X 1-5/8	X 1-5/8	-1-5/8	-1-5/8	-226	-226	226N	—	-26	-110	-110
1-11/16	X 1-11/16	X 1-11/16	-1-11/16	-1-11/16	-227	-227	227N	-27	-27	-111	-111
1-3/4	X 1-3/4	X 1-3/4	-1-3/4	-1-3/4	-228	-228	228N	-28	-28	-112	-112
1-7/8	X 1-7/8	X 1-7/8	—	-1-7/8	—	—	230N	—	-30	—	—
1-15/16	X 1-15/16	X 1-15/16	-1-15/16	-1-15/16	-231	-231	231N	-31	-31	-115	-115
2S	—	X 2S	-2, 210	—	—	—	2E32N	-32R	-32R	—	—
2	X 2	X 2	-2, 211	-2	-232	-232	232N	-32	-32	-200	-200
2-3/16	X 2-3/16	X 2-3/16	-2-3/16	-2-3/16	-235	-235	235N	-35	-35	-203	-203
2-1/4	X 2-1/4	X 2-1/4	-2-1/4, 212	-2-1/4	—	—	236N	-36	-36	-204	-204
2-7/16	X 2-7/16	X 2-7/16	-2-7/16	-2-7/16	-239	-239	239N	-39	-39	-207	-207

① Relube – Eccentric Lock ② Relube – Setscrew Lock

IndustrialLine™ Bearings



Series PB350 Cast Iron, PB350H HUB-ALLOY® Pillow Blocks

SHAFT SIZE	HUB CITY	BOSTON	DODGE	FAFNIR	BROWNING	SEALMASTER	SKF	MCGILL
	PB350 ^① PB350H ^②	MB ^①	SCM ^①	RAKH ^② LAKH ^{②③}	MPS ^① VPS ^①	MP ^① MRP ^{①③}	SYM-TM ^①	C-35 ^①
1	X 1	—	-1	‡-1	‡-316	‡-16	—	-1
1-3/16	X 1-3/16	—	-1-3/16	-1-3/16	-319	-19	—	-1-3/16
1-7/16	X 1-7/16	-1-7/16	-1-7/16	-1-7/16	-323	-23	-1-7/16	-1-7/16
1-1/2	X 1-1/2	-1-1/2	‡-1-1/2	-1-1/2	-324	-24	-1-1/2	-1-1/2
1-11/16	X 1-11/16	-1-11/16	‡-1-11/16	-1-11/16	-327	-27	-1-11/16	‡-1-11/16
1-3/4	X 1-3/4	-1-3/4	‡-1-3/4	-1-3/4	-238	-28	-1-3/4	-1-3/4
1-15/16	X 1-15/16	-1-15/16	-1-15/16	-1-15/16	-331	-31	-1-15/16	-1-15/16
2	X 2	-2	-2	‡-2	-332	-32	-2	-2
2-3/16	X 2-3/16	-2-3/16	-2-3/16	-2-3/16	-335	-35	-2-3/16	-2-3/16
2-1/4	X 2-1/4	-2-1/4	-2-1/4	‡-2-1/4	-336	-36	-2-1/4	-2-1/4
2-7/16	X 2-7/16	-2-7/16	-2-7/16	-2-7/16	-339	-39	-2-7/16	-2-7/16
2-1/2	X 2-1/2	-2-1/2	-2-1/2	—	-340	-40	-2-1/2	-2-1/2
2-11/16	X 2-11/16	-2-11/16	-2-11/16	-2-11/16	-343	-43	-2-11/16	-2-11/16
2-15/16	X 2-15/16	-2-15/16	-2-15/16	-2-15/16	-347	-47	-2-15/16	-2-15/16
3	X 3	-3	-3	—	-348	-48	-3	-3
3-7/16	X 3-7/16	-3-7/16	-3-7/16	—	-355	-55	-3-7/16	-3-7/16
3-1/2	X 3-1/2	-3-1/2	-3-1/2	—	-356	-56	-3-1/2	-3-1/2

① Relube – Setscrew Lock ② Relube – Eccentric Lock ③ Not all sizes available

‡ Not dimensionally interchangeable

INTERCHANGES ARE FOR COMPARISON PURPOSES, DIMENSIONS AND RATINGS MAY VARY.

DOWNLOAD AVAILABLE CAD MODELS AT: WWW.HUBCITYINC.COM

Certified prints are available upon request

EMAIL: hubsales@regalbeloit.com • www.hubcityinc.com



Hub City IndustrialLine™ Bearing Units

Interchange Comparisons

Series FB350 Cast Iron; FB350H HUB-ALLOY® Four-Hole Flange Blocks

SHAFT SIZE	HUB CITY	BOSTON	DODGE	FAFNIR	BROWNING	SEALMASTER	SKF	MCGILL
	FB350 ① FB350H ①	MBF ①	SCM-4 ①	RCJO ②	MF4S ① VF4S ①	MSF ① MRF ①	FLY-TM ①	FC4-35 ①
1	X 1	—	-1	—	-316	-16	—	-1
1-3/16	X 1-3/16	—	-1-3/16	-1-3/16	-319	-19	—	-1-3/16
1-7/16	X 1-7/16	-1-7/16	-1-7/16	-1-7/16	-323	-23	-1-7/16	-1-7/16
1-1/2	X 1-1/2	-1-1/2	-1-1/2	-1-1/2	-324	-24	-1-1/2	-1-1/2
1-11/16	X 1-11/16	-1-11/16	-1-11/16	-1-11/16	-327	-27	-1-11/16	-1-11/16
1-3/4	X 1-3/4	-1-3/4	-1-3/4	—	-328	-28	-1-3/4	-1-3/4
1-15/16	X 1-15/16	-1-15/16	-1-15/16	-1-15/16	-331	-31	-1-15/16	-1-15/16
2	X 2	-2	-2	—	-332	-32	-2	-2
2-3/16	X 2-3/16	-2-3/16	-2-3/16	-2-3/16	-335	-35	-2-3/16	-2-3/16
2-1/4	X 2-1/4	-2-1/4	-2-1/4	—	-336	-36	-2-1/4	-2-1/4
2-7/16	X 2-7/16	-2-7/16	-2-7/16	-2-7/16	-339	-39	-2-7/16	-2-7/16
2-1/2	X 2-1/2	-2-1/2	-2-1/2	—	-340	-40	-2-1/2	-2-1/2
2-11/16	X 2-11/16	-2-11/16	-2-11/16	-2-11/16	-343	-43	-2-11/16	-2-11/16
2-15/16	X 2-15/16	-2-15/16	-2-15/16	-2-15/16	-347	-47	-2-15/16	-2-15/16
3	X 3	-3	-3	—	-348	-48	-3	-3
3-7/16	X 3-7/16	-3-7/16	-3-7/16	-3-7/16	-355	-55	-3-7/16	-3-7/16
3-1/2	X 3-1/2	-3-1/2	-3-1/2	—	-356	-56	-3-1/2	-3-1/2

① RELUBE – SETSCREW LOCK ② RELUBE – ECCENTRIC LOCK

Series FC350 Cast Iron Four-Hole Flange Cartridges

SHAFT SIZE	HUB CITY	BOSTON	DODGE	FAFNIR	BROWNING	SEALMASTER	MCGILL
	FC350 ①	MBP ①	SCM ①	RFC ②	MFCS ① VFCS ①	MFC ① MRFC ①	PFC4-35 ①
1-1/4	X 1-1/4	—	—	-1-1/4S	-320	-20	-1-1/4
1-7/16	X 1-7/16	-1-7/16	-1-7/16	-1-7/16	-323	-23	-1-7/16
1-1/2	X 1-1/2	-1-1/2	-1-1/2	-1-1/2	-234	-24	-1-1/2
1-11/16	X 1-11/16	-1-11/16	-1-11/16	-1-11/16	-327	-27	-1-11/16
1-3/4	X 1-3/4	-1-3/4	-1-3/4	-1-3/4	-328	-28	-1-3/4
1-15/16	X 15/16	-1-15/16	-1-15/16	-1-15/16	-331	-31	-1-15/16
2	X 2	-2	-2	-2	-332	-32	-2
2-3/16	X 2-3/16	-2-3/16	-2-3/16	-2-3/16	-335	-35	-2-3/16
2-1/4	X 2-1/4	-2-1/4	-2-1/4	—	-336	-36	-2-1/4
2-7/16	X 2-7/16	-2-7/16	-2-7/16	—	-339	-39	-2-7/16
2-1/2	X 2-1/2	-2-1/2	-2-1/2	—	-340	-40	-2-1/2
2-11/16	X 2-11/16	-2-11/16	—	—	-343	-43	-2-11/16
2-15/16	X 2-15/16	-2-15/16	-2-15/16	—	-347	-47	-2-15/16
3	X 3	-3	-3	—	-348	-48	-3
3-7/16	X 3-7/16	-3-7/16	-3-7/16	—	-355	-55	-3-7/16
3-1/2	X 3-1/2	-3-1/2	-3-1/2	—	-356	-56	-3-1/2

① RELUBE – SETSCREW LOCK ② RELUBE – ECCENTRIC LOCK

INTERCHANGES ARE FOR COMPARISON PURPOSES, DIMENSIONS AND RATINGS MAY VARY.

DOWNLOAD AVAILABLE CAD MODELS AT: WWW.HUBCITYINC.COM

Certified prints are available upon request

CALL: (605) 225-0360 • FAX: (605) 225-0567

Hub City DuraLine® Bearing Units

DuraLine® Features	N-2
Load Ratings	N-3
Pillow Blocks	N-4 to N-10
Flange Blocks	N-11 to N-16
Flange Cartridge Bearings	N-17
Flange Bracket Bearings.....	N-17
Take Up Units	N-18
200 Series Bearing Inserts	N-23
Medium Duty Bearings.....	N-25
Competitor Product Interchange.....	N-28

Over 325 NEW items in this section!

Hub City DuraLine® Bearing Units

Features

- Reliable Performance
- Economical Durability
- Bore Sizes Up to 3-1/2"
- Cast Iron Pillow Blocks
- Cast Iron and Ductile Iron Flange Blocks
- Cast Iron Flange Brackets
- Normal Duty and Medium Duty Sizes
- Take Up Units
- Setscrew Lock and Eccentric Lock Inserts
- Wide and Narrow Inner Race Inserts
- Self-Aligning Replacement Bearings
- Pre-Lubricated with Lithium Grease
- Steel Retainers
- Anti-rotation Pins
- Nitrile Rubber Seals with Steel Trash Guards
- Precision Bored Housings



For Additional Mounted Bearing
Choices
See IndustriaLine
Section M

DOWNLOAD AVAILABLE CAD MODELS AT: WWW.HUBCITYINC.COM

Certified prints are available upon request

CALL: (605) 225-0360 • FAX: (605) 225-0567

Hub City DuraLine® Bearing Units

Load Ratings

BEARING RADIAL LOAD CAPACITY (POUNDS) FOR 500 HOURS L-10 LIFE (2500 HOURS AVERAGE LIFE) AND STEADY LOAD CONDITIONS											
SHAFT SIZE (INCHES)		BASIC DYNAMIC RATING, C* (POUNDS)	BASIC STATIC RATING, Co** (POUNDS)	BEARING SPEED (RPM)							
100, 200 SERIES	300 SERIES			100	500	1,000	1,500	2,000	2,500	3,000	3,500
1/2 to 5/8		2150	1070	1,490	870	690	600	550	510	480	460
3/4		2880	1490	2,000	1,170	930	810	740	680	640	610
7/8 to 1		3150	1770	2,180	1,280	1010	890	800	750	700	670
1-1/8 to 1-1/4S	1	4380	2520	3,040	1,780	1410	1230	1120	1040	980	930
1-1/4 to 1-7/16		5780	3420	4,010	2,340	1860	1620	1480	1370	1290	
1-1/2	1-7/16	6650	4090	4,610	2,700	2140	1870	1700	1580	1480	
1-5/8 to 1-3/4	1-1/2	7160	4680	4,960	2,900	2300	2010	1830	1700		
1-7/8 to 2S	1-5/8 to 1-3/4	7890	5220	5,470	3,200	2540	2220	2020	1870		
2 to 2-3/16	1-15/16 to 2	9790	6560	6,790	3,970	3150	2750	2500			
2-1/4 to 2-7/16	2-3/16	10750	7370	7,450	4,360	3460	3020	2750			
	2-7/16 to 2-1/2	13670	10120	9,480	5,540	4400	3840				
2-15/16	2-11/16	14840	11130	10,290	6,020	4780	4170				
	2-15/16 to 3	16070	12180	11,140	6,520	5170	4520				
	3-7/16 to 3-1/2	21560	16070	14,950	8,740	6940	6060				

TO MODIFY THE ABOVE RATINGS
FOR OTHER L-10 LIFE REQUIREMENTS OR FOR SHOCK LOADS
MULTIPLY THE ABOVE RATINGS BY THE FACTOR FROM THIS CHART

MODIFICATION FACTORS FOR L-10 SERVICE LIFE AND LOAD CONDITIONS:

LOAD CONDITIONS	L-10 LIFE (HOURS)													
	500	700	1,000	1,500	2,000	3,000	4,000	5,000	7,000	10,000	15,000	20,000	30,000	50,000
Steady Load	1.00	.894	.794	.694	.630	.550	.500	.464	.415	.368	.322	.292	.255	.215
Light Shock	.90	.804	.715	.624	.567	.495	.450	.418	.373	.331	.290	.263	.230	.194
Moderate Shock	.70	.626	.556	.485	.441	.385	.350	.325	.290	.258	.225	.205	.179	.151

* Radial load for an L-10 rating life of 1,000,000 revolutions.

** Radial load rating for stationary or very low speed operation.

Maximum Recommended Speeds:

100, 200 Series	300 Series	
1/2 to 1-1/4S	1	3,500 RPM
1-1/4 to 1-1/2	1-3/16 to 1-7/16	3,000 RPM
1-5/8 to 2S	1-1/2 to 1-3/4	2,500 RPM
2 to 2-7/16	1-15/16 to 2-1/4	2,000 RPM
	2-7/16 to 2-11/16	1,700 RPM
	2-15/16 to 3-1/2	1,500 RPM

For ultimate life, snug fit or light press fit on shaft should be used.

Recommended operating temperature range: -25 to +225 deg F.

For applications not covered in the rating tables, consult the factory.

Ratings are based on ISO 281.

Ratings are based on snug or light press fit on shaft. Multiply ratings by 0.8 for loose shaft fits.

FOR LUBRICATION AND MOUNTING
INSTRUCTIONS REFER TO SECTION S.

DOWNLOAD AVAILABLE CAD MODELS AT: WWW.HUBCITYINC.COM

Certified prints are available upon request

EMAIL: hubsales@regalbeloit.com • www.hubcityinc.com



Hub City DuraLine® Bearing Units

Ductile Iron Pillow Blocks

Series PB120UR

- Relube type. Prelubricated at factory
- Eccentric locking collar
- Self-aligning replaceable bearing
- Nitrile rubber seals with steel trash guard
- Precision bored high strength Ductile Iron housing

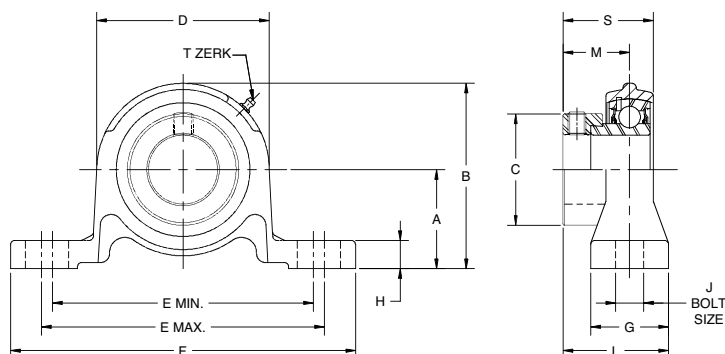

SHAFT SIZE	DIMENSIONS													WT. LBS.
	A	B	C	D	E		F	G	H	J	L	M	S	
					MIN.	MAX.								
1/2, 5/8	1.1870	2.1600	1.1020	2.1300	3.2200	3.6300	4.5000	0.9800	0.2800	0.4300	1.3600	0.8890	1.1260	0.6
3/4	1.3120	2.4400	1.2990	2.4000	3.5900	4.0300	4.9200	1.0600	0.3100	0.4300	1.4600	0.9450	1.2200	0.8
7/8, 1	1.4370	2.7200	1.4760	2.5600	3.7500	4.1200	5.1200	1.1400	0.3500	0.4100	1.5000	0.9250	1.2200	1.0
1-1/8, 1-3/16, 1-1/4s	1.6870	3.1900	1.7320	3.0000	4.4700	4.9700	6.1400	1.3000	0.3900	0.5500	1.7000	1.0910	1.4060	1.4
1-1/4, 1-3/8, 1-7/16	1.8750	3.5800	2.1650	3.4300	4.7500	5.2500	6.5000	1.3800	0.3900	0.5500	1.8500	1.1970	1.5310	1.9

Part Numbers are specified by "PB120" and Bore Size; Example: PB120UR x 1-1/8.

For Load Ratings, see page N-3.

For replacement inserts use B220R Bearing Inserts, see page N-22.

Series PB150UR

- Relube type. Prelubricated at factory
- Setscrew locking
- Self-aligning replaceable bearing
- Nitrile rubber seals with steel trash guard
- Precision bored high strength Ductile Iron housing

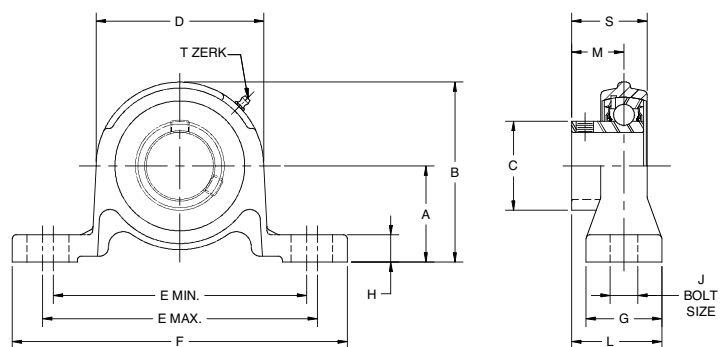

SHAFT SIZE	DIMENSIONS													WT. LBS.
	A	B	C	D	E		F	G	H	J	L	M	S	
					MIN.	MAX.								
1/2, 5/8	1.1870	2.1600	0.9210	2.1300	3.2200	3.6300	4.5000	0.9800	0.2800	0.4300	1.1000	0.6290	0.8660	0.6
3/4	1.3120	2.4400	1.1420	2.4000	3.5900	4.0300	4.9200	1.0600	0.3100	0.4300	1.2240	0.7090	0.9840	0.8
7/8, 1	1.4370	2.7200	1.3390	2.5600	3.7500	4.1200	5.1200	1.1400	0.3500	0.4100	1.3430	0.7680	1.0630	1.0
1-1/8, 1-3/16, 1-1/4s	1.6870	3.1900	1.5870	3.0000	4.4700	4.9700	6.1400	1.3000	0.3900	0.5500	1.4750	0.8660	1.1810	1.4
1-1/4, 1-3/8, 1-7/16	1.8750	3.5800	1.8890	3.4300	4.7500	5.2500	6.5000	1.3800	0.3900	0.5500	1.5780	0.9250	1.2590	1.9

Part Numbers are specified by "PB150" and Bore Size; Example: PB150UR x 1-1/8.

For Load Ratings, see page N-3.

For replacement inserts use B250R Bearing Inserts, see page N-22.

⚠ DIMENSIONS SHOWN ARE FOR REFERENCE ONLY.

DOWNLOAD AVAILABLE CAD MODELS AT: WWW.HUBCITYINC.COM

Certified prints are available upon request

CALL: (605) 225-0360 • FAX: (605) 225-0567

Hub City DuraLine® Bearing Units

Pillow Blocks

Series PB220UR, PB221UR

Features

- Self-aligning replaceable bearing
- Pre-lubricated with lithium grease
- Steel retainers
- Anti-rotation pins
- Nitrile rubber seals with steel trash guards
- Precision bored housings



200 SERIES 2 BOLT PILLOW BLOCK – ECCENTRIC LOCK

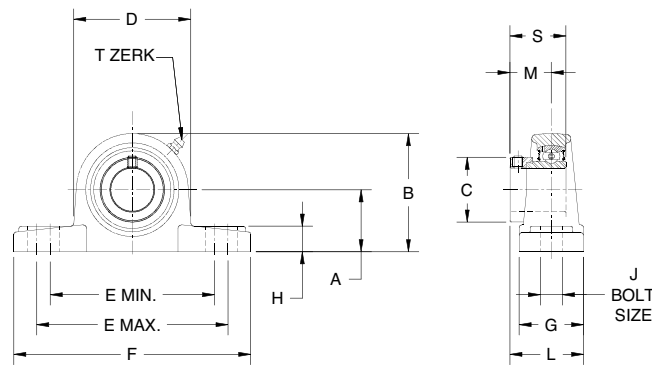

200 SERIES – 2 BOLT PILLOW BLOCKS – CAST IRON – ECCENTRIC LOCK – RELUBE TYPE

PB220UR (FOR LOW SHAFT HEIGHTS)

SHAFT SIZE	A	B	C	D	E MIN.	E MAX.	F	G	H	J	L	M	S	WT. LBS.
1/2, 5/8	1.0630	2.1300	1.1025	2.2400	3.3100	3.7000	4.7600	1.3800	0.5200	0.4700	1.6400	0.8900	1.1260	1.1
3/4	1.2520	2.5200	1.2990	2.6400	3.6600	4.0600	5.2400	1.6100	0.5600	0.4700	1.6900	0.9450	1.2200	1.8
7/8, 1	1.3110	2.6900	1.4760	2.8000	3.9400	4.3300	5.5100	1.7700	0.6300	0.4700	1.6700	0.9250	1.2200	2.3
1-1/8, 1-3/16, 1-1/4s	1.5630	3.1500	1.7320	3.2700	4.6100	4.9200	6.3000	1.8800	0.6700	0.5900	2.0400	1.0910	1.4060	2.8
1-1/4, 1-3/8, 1-7/16	1.8110	3.6200	2.1650	3.8600	4.8400	5.1600	6.5700	1.8800	0.7500	0.5900	2.1400	1.1970	1.5320	3.7
1-1/2	1.9380	3.9400	2.2830	4.1700	5.3500	5.6700	7.1300	2.1300	0.7500	0.5900	2.4300	1.3660	1.7200	4.2
1-5/8, 1-11/16, 1-3/4	2.0630	4.1900	2.4800	4.5300	5.5900	5.9100	7.4800	2.1300	0.8300	0.5900	2.4100	1.3460	1.7200	4.8
1-7/8, 1-15/16, 2S	2.1890	4.4500	2.7160	4.8000	6.0200	6.5000	8.0000	2.2500	0.8700	0.7800	2.5100	1.3260	1.7200	5.9
2, 2-3/16	2.4370	4.9200	2.9920	5.3100	6.8900	7.3600	9.1300	2.3600	0.9800	0.7800	2.6700	1.4920	1.9060	8.3
2-1/4, 2-7/16	2.6880	5.4400	3.3110	5.8300	7.2400	7.7200	9.5000	2.5300	1.1400	0.7800	2.8800	1.5040	1.9370	10.9

PB221UR (FOR HIGH SHAFT HEIGHTS)

SHAFT SIZE	A	B	C	D	E MIN.	E MAX.	F	G	H	J	L	M	S	WT. LBS.
1/2, 5/8	1.1880	2.4400	1.1020	2.3600	3.4400	4.0600	5.0000	1.5000	0.5600	0.5300	1.6400	0.8900	1.1260	1.2
3/4	1.3110	2.5600	1.2990	2.5600	3.4400	4.0600	5.0000	1.5000	0.5600	0.5300	1.6900	0.9450	1.2200	1.9
7/8, 1	1.4370	2.8000	1.4760	2.8700	3.8100	4.4400	5.5100	1.5000	0.5900	0.5300	1.6700	0.9250	1.2200	2.4
1-1/8, 1-3/16, 1-1/4s	1.6880	3.2700	1.7320	3.3900	4.5300	5.0000	6.5000	1.8800	0.6700	0.6700	2.0400	1.0910	1.4060	2.9
1-1/4, 1-3/8, 1-7/16	1.8750	3.6600	2.1650	3.7400	4.7500	5.2500	6.5700	1.8800	0.7200	0.6700	2.1400	1.1970	1.5320	4.1
1-1/2	1.9380	3.9000	2.2830	4.1300	5.1600	5.6300	7.2500	2.1300	0.7200	0.6700	2.4300	1.3660	1.7200	4.3
1-5/8, 1-11/16, 1-3/4	2.1250	4.1900	2.4800	4.4100	5.5000	6.0000	7.5000	2.1300	0.7800	0.6700	2.4100	1.3460	1.7200	4.9
1-7/8, 1-15/16, 2S	2.2500	4.5000	2.7160	4.6900	6.0000	6.5300	8.1200	2.3600	0.8100	0.7800	2.5100	1.3260	1.7200	6.1
2, 2-3/16	2.5000	4.9600	2.9920	5.0800	6.4400	7.0000	8.6200	2.3600	0.9100	0.7800	2.6700	1.4920	1.9060	9.0
2-1/4, 2-7/16	2.7500	5.4400	3.3110	5.6700	6.9700	7.5000	9.5000	2.7500	0.9800	0.7800	2.8800	1.5040	1.9370	11.1

For Load Ratings, See Page N-3

T-Zerk: 1/4-28 Taper

DuraLine Replacement Inserts

For 100 and 200 Series Setscrew Lock Use B250R, for 100 and 200 Series Eccentric Lock Use B220R, for 300 Series Setscrew Lock Use B350R

Dimensions shown are for reference only.

To order, specify type and bore size. Example: PB220UR x 1-7/16

DOWNLOAD AVAILABLE CAD MODELS AT: WWW.HUBCITYINC.COM

Certified prints are available upon request

EMAIL: hubsales@regalbeloit.com • www.hubcityinc.com



Hub City DuraLine® Bearing Units

Pillow Blocks - Wide Inner Race

Series PB220DRW, PB221DRW

Features

- Ductile iron housings
- Higher strength and impact resistance for high shock loads
- Suitable to replace gray iron housed bearings
- Self-aligning replaceable bearing
- Pre-lubricated with lithium grease
- Steel retainers
- Anti-rotation pins
- Nitrile rubber seals with steel flingers
- Precision bored housings



200 SERIES 2 BOLT PILLOW BLOCK
ECCENTRIC LOCK – WIDE INNER RING

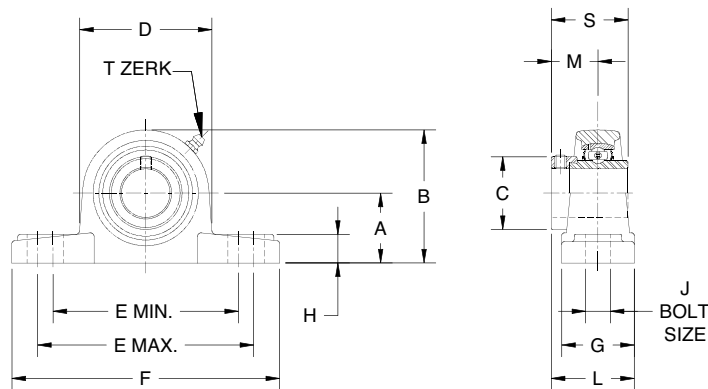

200 SERIES - 2 BOLT PILLOW BLOCKS - DUCTILE IRON - ECCENTRIC LOCK - RELUBE TYPE - WIDE INNER RING														
PB220DRW (FOR LOW SHAFT HEIGHTS)														
SHAFT SIZE	A	B	C	D	E MIN.	E MAX.	F	G	H	J	L	M	S	WT. LBS.
3/4	1.2500	2.5200	1.2990	2.6400	3.6800	4.0300	5.2500	1.6100	0.5600	0.4720	1.8500	1.0490	1.7200	1.9
7/8, 1	1.3120	2.6800	1.4760	2.8000	3.9600	4.3100	5.5000	1.7700	0.6300	0.4720	1.9500	1.0610	1.7480	2.4
1-1/8, 1-3/16, 1-1/4s	1.5620	3.1500	1.7320	3.2700	4.6000	4.9300	6.3100	1.8900	0.6700	0.5900	2.1300	1.1870	1.9060	3.0
1-1/4, 1-3/8, 1-7/16	1.8120	3.6200	2.1650	3.8600	4.8300	5.1700	6.5600	1.8900	0.7500	0.5900	2.2200	1.2740	2.0160	3.9
1-1/2	1.9370	3.8600	2.2830	4.1700	5.3500	5.6800	7.1030	2.1300	0.7500	0.5900	2.4400	1.3760	2.2200	4.5
1-5/8, 1-11/16, 1-3/4	2.0620	4.1700	2.4800	4.5300	5.5800	5.9200	7.5000	2.1300	0.8300	0.5900	2.4400	1.3760	2.2200	5.1
1-7/8, 1-15/16, 2s	2.1870	4.4900	2.7170	4.8000	6.0200	6.5000	8.0000	2.2400	0.8700	0.7870	2.6200	1.5000	2.4690	6.4
2, 2-3/16	2.4370	4.9600	2.9920	5.3100	6.8900	7.3000	9.1300	2.3600	0.9800	0.7870	2.9000	1.7170	2.8110	8.8
2-1/4, 2-7/16	2.6870	5.4300	3.3110	5.8300	7.2400	7.7200	9.5000	2.5200	1.1400	0.7870	3.1000	1.8440	3.0630	11.4

PB221DRW (FOR HIGH SHAFT HEIGHTS)														
SHAFT SIZE	A	B	C	D	E MIN.	E MAX.	F	G	H	J	L	M	S	WT. LBS.
3/4	1.3120	2.5600	1.2990	2.6400	3.5000	4.0900	5.0000	1.5000	0.5500	0.5120	1.8000	1.0490	1.7200	2.0
7/8, 1	1.4370	2.8000	1.4760	2.8000	3.9000	4.3700	5.5000	1.5000	0.5900	0.5120	1.8100	1.0610	1.7480	2.5
1-1/8, 1-3/16, 1-1/4s	1.6870	3.2700	1.7320	3.2700	4.5600	4.9700	6.5000	1.8900	0.6700	0.6700	2.1300	1.1870	1.9060	3.1
1-1/4, 1-3/8, 1-7/16	1.8750	3.6600	2.1650	3.8600	4.7900	5.2100	6.5600	1.8900	0.7100	0.6700	2.2200	1.2740	2.0160	4.3
1-1/2	1.9370	3.8600	2.2830	4.1700	5.1900	5.6000	7.2500	2.1300	0.7100	0.6700	2.2500	1.3760	2.2200	4.6
1-5/8, 1-11/16, 1-3/4	2.1250	4.1700	2.4800	4.5300	5.5400	5.9600	7.5000	2.1300	0.7900	0.6700	2.2500	1.3760	2.2200	5.2
1-7/8, 1-15/16, 2s	2.2500	4.4900	2.7170	4.8000	6.0400	6.5200	8.1200	2.3600	0.8300	0.7870	2.4600	1.5000	2.4690	6.6
2, 2-3/16	2.5000	4.9600	2.9920	5.3100	6.4800	7.0100	8.6200	2.3600	0.9100	0.7870	2.5000	1.7170	2.8110	9.5
2-1/4, 2-7/16	2.7500	5.4300	3.3110	5.8300	6.9900	7.5000	9.5000	2.7500	0.9800	0.7870	2.9400	1.8440	3.0630	11.5

For Load Ratings, See Page N-3
T-Zerk: 1/4-28 Taper

DuraLine Replacement Inserts
For 100 and 200 Series Setscrew Lock Use B250RW, for 100 and 200 Series Eccentric Lock Use B220RW

Dimensions shown are for reference only.
To order, specify type and bore size.
Example: PB220DRW x 1-7/16

DOWNLOAD AVAILABLE CAD MODELS AT: WWW.HUBCITYINC.COM

Certified prints are available upon request

CALL: (605) 225-0360 • FAX: (605) 225-0567

Hub City DuraLine® Bearing Units

Pillow Blocks

Series PB250UR, PB251UR

Features

- Self-aligning replaceable bearing
- Pre-lubricated with lithium grease
- Steel retainers
- Anti-rotation pins
- Nitrile rubber seals with steel trash guards
- Precision bored housings



200 SERIES 2 BOLT PILLOW BLOCK – SETSCREW LOCK

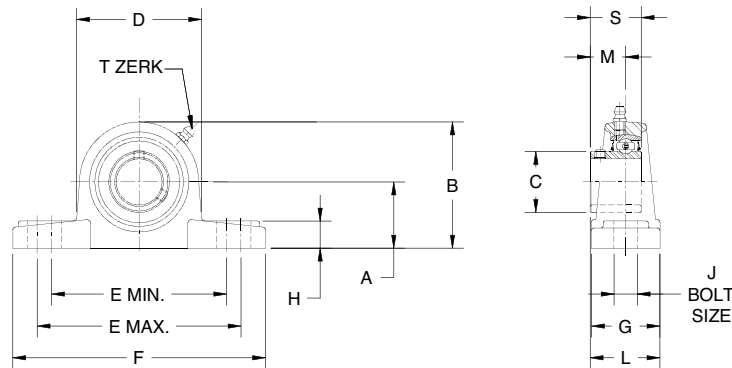

200 SERIES – 2 BOLT PILLOW BLOCKS – CAST IRON – SETSCREW LOCK – RELUBE TYPE														
PB250UR (FOR LOW SHAFT HEIGHTS)														
SHAFT SIZE	A	B	C	D	E MIN.	E MAX.	F	G	H	J	L	M	S	WT. LBS.
1/2, 5/8	1.0630	2.1300	0.9210	2.2400	3.3100	3.7000	4.7600	1.3800	0.5200	0.4700	1.3200	0.6300	0.8670	1.2
3/4	1.2520	2.5200	1.1410	2.6400	3.6600	4.0600	5.2400	1.6100	0.5600	0.4700	1.5200	0.7100	0.9840	1.8
7/8, 1	1.3110	2.6900	1.3390	2.8000	3.9400	4.3300	5.5100	1.7700	0.6300	0.4700	1.6500	0.7680	1.0630	2.3
1-1/8, 1-3/16, 1-1/4s	1.5630	3.1500	1.5870	3.2700	4.6100	4.9200	6.3000	1.8800	0.6700	0.5900	1.8100	0.8660	1.1810	2.8
1-1/4, 1-3/8, 1-7/16	1.8110	3.6200	1.8900	3.8600	4.8400	5.1600	6.5700	1.8800	0.7500	0.5900	1.8700	0.9250	1.2600	3.6
1-1/2	1.9380	3.9400	2.0870	4.1700	5.3500	5.6700	7.1300	2.1300	0.7500	0.5900	2.0500	0.9840	1.3390	4.5
1-5/8, 1-11/16, 1-3/4	2.0630	4.1900	2.2520	4.5300	5.5900	5.9100	7.4800	2.1300	0.8300	0.5900	2.3100	1.2200	1.6220	5.1
1-7/8, 1-15/16, 2S	2.1890	4.4500	2.4330	4.8000	6.0200	6.5000	8.0000	2.2500	0.8700	0.7800	2.4400	1.2830	1.7130	6.0
2, 2-3/16	2.4370	4.9200	2.7170	5.3100	6.8900	7.3600	9.1300	2.3600	0.9800	0.7800	2.5500	1.3190	1.7830	8.2
2-1/4, 2-7/16	2.6880	5.4400	2.9490	5.8300	7.2400	7.7200	9.5000	2.5300	1.1400	0.7800	2.9400	1.5280	2.1140	10.9

PB251UR (FOR HIGH SHAFT HEIGHTS)														
SHAFT SIZE	A	B	C	D	E MIN.	E MAX.	F	G	H	J	L	M	S	WT. LBS.
1/2, 5/8	1.1880	2.4400	0.9210	2.3600	3.4400	4.0600	5.0000	1.5000	0.5600	0.5300	1.3800	0.6300	0.8670	1.3
3/4	1.3110	2.5600	1.1410	2.5600	3.4400	4.0600	5.0000	1.5000	0.5600	0.5300	1.4700	0.7100	0.9840	1.9
7/8, 1	1.4370	2.8000	1.3390	2.8700	3.8100	4.4400	5.5100	1.5000	0.5900	0.5300	1.5200	0.7680	1.0630	2.4
1-1/8, 1-3/16, 1-1/4s	1.6880	3.2700	1.5870	3.3900	4.5300	5.0000	6.5000	1.8800	0.6700	0.6700	1.8100	0.8660	1.1810	2.9
1-1/4, 1-3/8, 1-7/16	1.8750	3.6600	1.8900	3.7400	4.7500	5.2500	6.5700	1.8800	0.7200	0.6700	1.8700	0.9250	1.2600	4.0
1-1/2	1.9380	3.8970	2.0870	4.1300	5.1600	5.6300	7.2500	2.1300	0.7200	0.6700	2.0000	0.9840	1.3390	4.6
1-5/8, 1-11/16, 1-3/4	2.1250	4.1900	2.2520	4.4100	5.5000	6.0000	7.5000	2.1300	0.7800	0.6700	2.2800	1.2200	1.6220	5.2
1-7/8, 1-15/16, 2S	2.2500	4.5000	2.4330	4.6900	6.0000	6.5300	8.1200	2.3600	0.8100	0.7800	2.5000	1.2830	1.7130	6.2
2, 2-3/16	2.5000	4.9600	2.7170	5.0800	6.4400	7.0000	8.6200	2.3600	0.9100	0.7800	2.5500	1.3190	1.7830	8.4
2-1/4, 2-7/16	2.7500	5.4400	2.9490	5.6700	6.9700	7.5000	9.5000	2.7500	0.9800	0.7800	3.0600	1.5280	2.1140	11.1

For Load Ratings, See Page N-3
T-Zerk: 1/4-28 Taper

DuraLine Replacement Inserts
For 100 and 200 Series Setscrew Lock Use B250R, for 100 and 200 Series Eccentric Lock Use B220R, for 300 Series Setscrew Lock Use B350R

Dimensions shown are for reference only.
To order, specify type and bore size. Example:
PB250UR x 1-7/16

DOWNLOAD AVAILABLE CAD MODELS AT: WWW.HUBCITYINC.COM

Certified prints are available upon request

EMAIL: hubsales@regalbeloit.com • www.hubcityinc.com



Hub City DuraLine® Bearing Units

Pillow Blocks - Wide Inner Race

Series PB250DRW, PB251DRW

Features

- Ductile iron housings
- Higher strength and impact resistance for high shock loads
- Suitable to replace gray iron housed bearings
- Self-aligning replaceable bearing
- Pre-lubricated with lithium grease
- Steel retainers and anti-rotation pins
- Nitrile rubber seals with steel flingers
- Precision bored housings



200 SERIES 2 BOLT PILLOW BLOCK
SETScrew LOCK – WIDE INNER RING

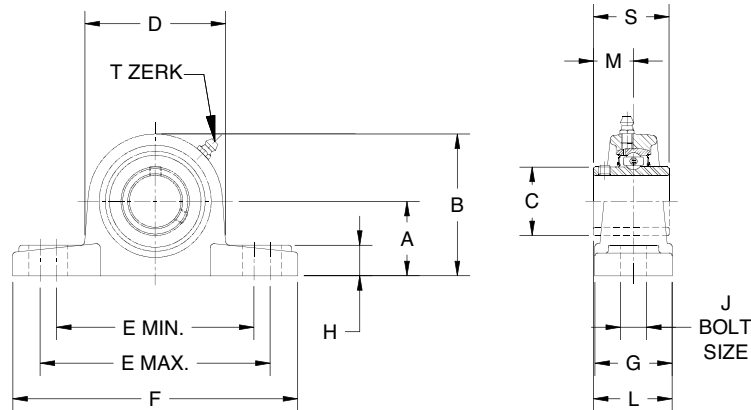

PB250DRW														
SHAFT SIZE	A	B	C	D	E MIN	E MAX	F	G	H	J	L	M	S	WT. LBS
1/2, 5/8	1.0620	2.1300	1.1300	2.2500	3.3300	3.6800	4.7500	1.3800	0.5100	0.4720	1.4100	0.7200	1.2200	1.2
3/4, 20mm	1.2500	2.5200	1.1420	2.6400	3.6800	4.0300	5.2500	1.6100	0.5600	0.4720	1.5300	0.7200	1.2200	1.9
7/8, 1, 25mm	1.3120	2.6800	1.3390	2.8000	3.9600	4.3100	5.5000	1.7700	0.6300	0.4720	1.6600	0.7760	1.3390	2.4
1-1/8, 1-3/16, 1-1/4s, 30mm	1.5620	3.1500	1.5910	3.2700	4.6000	4.9300	6.3100	1.8900	0.6700	0.5900	1.8200	0.8740	1.5000	3.0
1-1/4, 1-3/8, 1-7/16, 35mm	1.8120	3.6200	1.8660	3.8600	4.8300	5.1700	6.5600	1.8900	0.7500	0.5900	1.9500	1.0000	1.6890	3.8
1-1/2, 40mm	1.9370	3.9400	2.0750	4.1700	5.3500	5.6800	7.1300	2.1300	0.7500	0.5900	2.2500	1.1890	1.9370	4.8
1-5/8, 1-11/16, 1-3/4, 45mm	2.0620	4.1700	2.2480	4.5300	5.5800	5.9200	7.5000	2.1300	0.8300	0.5900	2.2500	1.1890	1.9370	5.4
1-7/8, 1-15/16, 2s, 50mm	2.1870	4.4500	2.4650	4.8000	6.0200	6.5000	8.0000	2.2400	0.8700	0.7870	2.4000	1.2830	2.0310	6.5
2, 2-3/16, 55mm	2.4370	4.9200	2.7760	5.3100	6.8900	7.3600	9.1300	2.3600	0.9800	0.7870	2.5000	1.3150	2.1890	8.7
2-1/4, 2-7/16, 60mm	2.6870	5.4300	3.0590	5.8300	7.2400	7.7200	9.5000	2.5200	1.1400	0.7870	2.8200	1.5630	2.5630	11.4

PB251DRW														
SHAFT SIZE	A	B	C	D	E MIN	E MAX	F	G	H	J	L	M	S	WT. LBS
1/2, 5/8	1.1870	2.4400	1.1300	2.2500	3.5100	3.9700	5.0000	1.5000	0.5500	0.5120	1.4700	0.7200	1.2200	1.3
3/4, 20mm	1.3120	2.5600	1.1420	2.6400	3.5000	4.0900	5.0000	1.5000	0.5500	0.5120	1.4800	0.7200	1.2200	2.0
7/8, 1, 25mm	1.4370	2.8000	1.3390	2.8000	3.9000	4.3700	5.5000	1.5000	0.5900	0.5120	1.5300	0.7760	1.3390	2.5
1-1/8, 1-3/16, 1-1/4s, 30mm	1.6870	3.2700	1.5910	3.2700	4.5600	4.9700	6.5000	1.8900	0.6700	0.6700	1.8200	0.8740	1.5000	3.1
1-1/4, 1-3/8, 1-7/16, 35mm	1.8750	3.6600	1.8660	3.8600	4.7900	5.2100	6.5600	1.8900	0.7100	0.6700	1.9500	1.0000	1.6890	4.2
1-1/2, 40mm	1.9370	3.8600	2.0750	4.1700	5.1900	5.6000	7.2500	2.1300	0.7100	0.6700	2.2500	1.1890	1.9370	4.9
1-5/8, 1-11/16, 1-3/4, 45mm	2.1250	4.1700	2.2480	4.5300	5.5400	5.9600	7.5000	2.1300	0.7900	0.6700	2.2500	1.1890	1.9370	5.5
1-7/8, 1-15/16, 2s, 50mm	2.2500	4.4900	2.4650	4.8000	6.0400	6.5200	8.1200	2.3600	0.8300	0.7870	2.4600	1.2830	2.0310	6.7
2, 2-3/16, 55mm	2.5000	4.9600	2.7760	5.3100	6.4800	7.0100	8.6200	2.3600	0.9100	0.7870	2.5000	1.3150	2.1890	8.9
2-1/4, 2-7/16, 60mm	2.7500	5.4300	3.0590	5.8300	6.9900	7.5000	9.5000	2.7500	0.9800	0.7870	2.9400	1.5630	2.5630	11.6

For Load Ratings, See Page N-3
T-Zerk: 1/4-28 Taper

DuraLine Replacement Inserts
For 100 and 200 Series Setscrew Lock Use B250RW, for 100 and 200 Series Eccentric Lock Use B220RW

Dimensions shown are for reference only.
To order, specify type and bore size.
Example: PB250DRW x 1-7/16

DOWNLOAD AVAILABLE CAD MODELS AT: WWW.HUBCITYINC.COM

Certified prints are available upon request

CALL: (605) 225-0360 • FAX: (605) 225-0567

Hub City DuraLine® Bearing Units

Tapped Base

Series TPB220UR

Features

- Self-aligning replaceable bearing
- Pre-lubricated with lithium grease
- Steel retainers
- Anti-rotation pins
- Nitrile rubber seals with steel trash guards
- Precision bored housings

200 SERIES PILLOW BLOCK ECCENTRIC LOCK

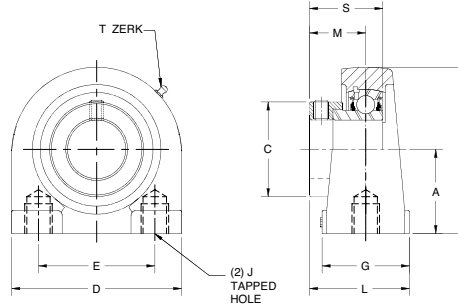

TPB220UR											
SHAFT SIZE	A	B	C	D	E	G	J - TAPPED HOLES	L	M	S	WT. LBS.
1/2, 5/8	1.3120	2.5600	1.1250	2.8700	2.0000	1.5000	3/8-16UNC X .50	1.6700	0.9210	1.4690	0.8
3/4	1.3120	2.5600	1.2990	2.8700	2.0000	1.5000	3/8-16UNC X .50	1.8000	1.0490	1.7200	1.0
7/8, 1	1.4370	2.8000	1.4760	3.0000	2.0000	1.5000	3/8-16UNC X .50	1.8100	1.0610	1.7480	1.5
1-1/8, 1-3/16, 1-1/4s	1.6870	3.3800	1.7320	4.0000	3.0000	1.5000	7/16-14UNC X .63	1.9400	1.1870	1.9060	2.2
1-1/4, 1-3/8, 1-7/16	1.8750	3.7400	2.1650	4.2500	3.2500	1.8900	1/2-13UNC X .78	2.2200	1.2740	2.0160	2.8
1-1/2	1.9370	3.9400	2.2830	4.6100	3.5000	1.8900	1/2-13UNC X .78	2.3200	1.3760	2.2200	3.8
1-5/8, 1-11/16, 1-3/4	2.1250	4.2500	2.4800	5.0000	3.7500	2.0000	1/2-13UNC X .78	2.3800	1.3760	2.2200	5.2
1-7/8, 1-15/16, 2s	2.2500	4.6500	2.7170	5.5000	4.0000	2.0000	5/8-11UNC X .90	2.5000	1.5000	2.4690	5.6
2, 2-3/16	2.2500	4.6500	2.9920	5.5000	4.0000	2.0000	5/8-11UNC X .98	2.7200	1.7170	2.8110	5.7

Tapped Base - Wide Inner Race

Series TPB220URW

Features

- Self-aligning replaceable bearing
- Pre-lubricated with lithium grease
- Steel retainers
- Anti-rotation pins
- Nitrile rubber seals with steel fingers
- Precision bored housings

200 SERIES PILLOW BLOCK ECCENTRIC LOCK – WIDE INNER RING

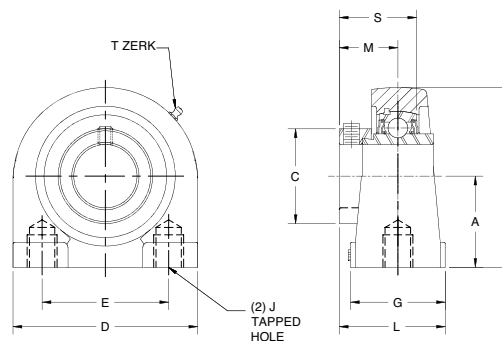

TPB220URW											
SHAFT SIZE	A	B	C	D	E	G	J - TAPPED HOLES	L	M	S	WT. LBS.
1/2, 5/8	1.3120	2.5600	1.1250	2.8700	2.0000	1.5000	3/8-16UNC X .50	1.6700	0.9210	1.4690	0.8
3/4	1.3120	2.5600	1.2990	2.8700	2.0000	1.5000	3/8-16UNC X .50	1.8000	1.0490	1.7200	1.0
7/8, 1	1.4370	2.8000	1.4760	3.0000	2.0000	1.5000	3/8-16UNC X .50	1.8100	1.0610	1.7480	1.5
1-1/8, 1-3/16, 1-1/4s	1.6870	3.3800	1.7320	4.0000	3.0000	1.5000	7/16-14UNC X .63	1.9400	1.1870	1.9060	2.2
1-1/4, 1-3/8, 1-7/16	1.8750	3.7400	2.1650	4.2500	3.2500	1.8900	1/2-13UNC X .78	2.2200	1.2740	2.0160	2.8
1-1/2	1.9370	3.9400	2.2830	4.6100	3.5000	1.8900	1/2-13UNC X .78	2.3200	1.3760	2.2200	3.8
1-5/8, 1-11/16, 1-3/4	2.1250	4.2500	2.4800	5.0000	3.7500	2.0000	1/2-13UNC X .78	2.3800	1.3760	2.2200	5.2
1-7/8, 1-15/16, 2s	2.2500	4.6500	2.7170	5.5000	4.0000	2.0000	5/8-11UNC X .90	2.5000	1.5000	2.4690	5.6
2, 2-3/16	2.2500	4.6500	2.9920	5.5000	4.0000	2.0000	5/8-11UNC X .98	2.7200	1.7170	2.8110	5.7

For Load Ratings, See Page N-3
T-Zerk: 1/4-28 Taper

DOWNLOAD AVAILABLE CAD MODELS AT: WWW.HUBCITYINC.COM
Certified prints are available upon request

EMAIL: hubsales@regalbeloit.com • www.hubcityinc.com



Hub City DuraLine® Bearing Units

Tapped Base

Series TPB250UR

200 SERIES PILLOW BLOCK SETSCREW LOCK

Features

- Self-aligning replaceable bearing
- Pre-lubricated with lithium grease
- Steel retainers
- Anti-rotation pins
- Nitrile rubber seals with steel trash guards
- Precision bored housings

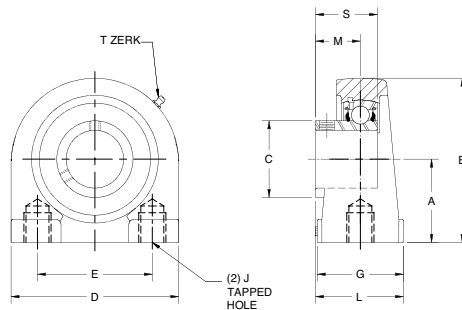

TPB250UR											
SHAFT SIZE	A	B	C	D	E	G	J - TAPPED HOLES	L	M	S	WT. LBS.
1/2, 5/8	1.3120	2.5600	0.9210	2.8700	2.0000	1.5000	3/8-16UNC X .50	1.3800	0.6300	0.8660	0.8
3/4	1.3120	2.5600	1.1410	2.8700	2.0000	1.5000	3/8-16UNC X .50	1.4600	0.7090	0.9840	0.9
7/8, 1	1.4370	2.8000	1.3390	3.0000	2.0000	1.5000	3/8-16UNC X .50	1.5200	0.7870	1.0630	1.4
1-1/8, 1-3/16, 1-1/4s	1.6870	3.3800	1.5870	4.0000	3.0000	1.5000	7/16-14UNC X .63	1.6200	0.8660	1.1810	2.0
1-1/4, 1-3/8, 1-7/16	1.8750	3.7400	1.8900	4.2500	3.2500	1.8900	7/16-14UNC X .78	1.8700	0.9240	1.2590	2.6
1-1/2	1.9370	3.9400	2.0870	4.6100	3.5000	1.8900	1/2-13UNC X .78	1.9300	0.9840	1.3380	3.5
1-5/8, 1-11/16, 1-3/4	2.1250	4.2500	2.2520	5.0000	3.7500	2.0000	1/2-13UNC X .78	2.2500	1.2480	1.6220	4.9
1-7/8, 1-15/16, 2S	2.2500	4.6500	2.4330	5.5000	4.0000	2.0000	5/8-11UNC X .90	2.3200	1.3190	1.7120	5.1
2, 2-3/16	2.2500	4.6500	2.7170	5.5000	4.0000	2.0000	5/8-11UNC X .98	2.3200	1.3700	1.7830	5.2

Tapped Base - Wide Inner Race

Series TPB250URW

200 SERIES PILLOW BLOCK SETSCREW LOCK – WIDE INNER RING

Features

- Self-aligning replaceable bearing
- Pre-lubricated with lithium grease
- Steel retainers
- Anti-rotation pins
- Nitrile rubber seals with steel flingers
- Precision bored housings

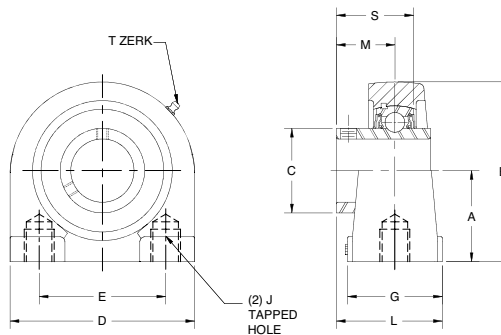

TPB250DRW											
SHAFT SIZE	A	B	C	D	E	G	J - TAPPED HOLES	L	M	S	WT. LBS.
1/2, 5/8	1.3120	2.5600	0.9690	2.8700	2.0000	1.5000	3/8-16UNC X .50	1.3800	0.6290	1.0240	0.8
3/4, 20mm	1.3120	2.5600	1.1420	2.8700	2.0000	1.5000	3/8-16UNC X .50	1.4600	0.7200	1.2200	1.0
7/8, 1, 25mm	1.4370	2.8000	1.3390	3.0000	2.0000	1.5000	3/8-16UNC X .50	1.5200	0.7760	1.3390	1.5
1-1/8, 1-3/16, 1-1/4s, 30mm	1.6870	3.3800	1.5910	4.0000	3.0000	1.5000	7/16-14UNC X .63	1.6200	0.8740	1.5000	2.2
1-1/4, 1-3/8, 1-7/16, 35mm	1.8750	3.7400	1.8660	4.2500	3.2500	1.8900	1/2-13UNC X .78	1.8700	1.0000	1.6890	2.8
1-1/2, 40mm	1.9370	3.9400	2.0750	4.6100	3.5000	1.8900	1/2-13UNC X .78	1.9300	1.1890	1.9370	3.8
1-5/8, 1-11/16, 1-3/4, 45mm	2.1250	4.2500	2.2480	5.0000	3.7500	2.0000	1/2-13UNC X .78	2.2500	1.1890	1.9370	5.2
1-7/8, 1-15/16, 2s, 50mm	2.2500	4.6500	2.4650	5.5000	4.0000	2.0000	5/8-11UNC X .90	2.3200	1.2830	2.0310	5.6
2, 2-3/16, 55mm	2.2500	4.6500	3.0590	5.5000	4.0000	2.0000	5/8-11UNC X .98	2.3200	1.3150	2.1890	5.7

For Load Ratings, See Page N-3
T-Zerk: 1/4-28 Taper

DOWNLOAD AVAILABLE CAD MODELS AT: WWW.HUBCITYINC.COM
Certified prints are available upon request

CALL: (605) 225-0360 • FAX: (605) 225-0567

Hub City DuraLine® Bearing Units

Flange Blocks

Series FB110UR, FB130UR, FB160UR

100 SERIES 2 BOLT FLANGE BLOCK SETSCREW LOCK

Features

- Self-aligning replaceable bearing
- Pre-lubricated with lithium grease
- Steel retainers
- Anti-rotation pins
- Nitrile rubber seals with steel trash guards
- ❖ Precision bored housings

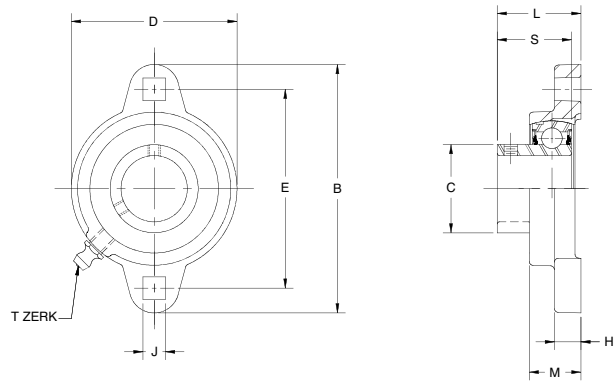

100 SERIES – 2 BOLT FLANGE BLOCKS – DUCTILE IRON – SETSCREW LOCK										
FB110UR (NON-RELUBE) & FB160UR (RELUBE)										
SHAFT SIZE	B	C	D	E	H	J	L	M	S	WT. LBS.
1/2, 5/8	3.1900	0.9210	2.2000	2.5000	0.3800	0.2800	1.0000	0.7100	0.8660	0.6
3/4	3.5400	1.1420	2.4000	2.8150	0.4300	0.3400	1.1400	0.7900	0.9840	0.8
7/8, 1	3.7400	1.3390	2.5200	2.9920	0.4300	0.3400	1.2000	0.7900	1.0630	0.8
1-1/8, 1-3/16, 1-1/4s	4.4500	1.5870	2.9900	3.5600	0.4700	0.4100	1.3400	0.8900	1.1810	1.1
1-1/4, 1-3/8, 1-7/16	4.8000	1.8890	3.5000	3.9370	0.5100	0.4100	1.4400	0.9400	1.2600	1.5

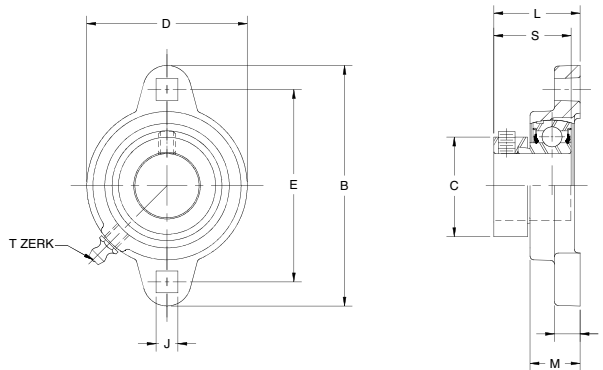

100 SERIES – 2 BOLT FLANGE BLOCKS – DUCTILE IRON – ECCENTRIC LOCK										
FB130UR										
SHAFT SIZE	B	C	D	E	H	J	L	M	S	WT. LBS.
1/2, 5/8	3.1900	1.1020	2.2000	2.5000	0.3800	0.2800	1.2600	0.7100	1.1260	0.6
3/4	3.5400	1.2990	2.4000	2.8150	0.4300	0.3400	1.3800	0.7900	1.2200	0.8
7/8, 1	3.7400	1.4760	2.5200	2.9920	0.4300	0.3400	1.3600	0.7900	1.2200	0.8
1-1/8, 1-3/16, 1-1/4s	4.4500	1.7320	2.9900	3.5600	0.4700	0.4100	1.5600	0.8900	1.4050	1.1
1-1/4, 1-3/8, 1-7/16	4.8000	2.1650	3.5000	3.9370	0.5100	0.4100	1.7100	0.9400	1.5310	1.5

For Load Ratings, See Page N-3
T-Zerk: 1/4-28 Taper

DuraLine Replacement Inserts
For 100 Series Setscrew Lock Use B250R, for 100 Series Eccentric Lock Use B220R,

Dimensions shown are for reference only.
To order, specify type and bore size. Example:
FB260UR x 1-7/16

DOWNLOAD AVAILABLE CAD MODELS AT: WWW.HUBCITYINC.COM
Certified prints are available upon request

EMAIL: hubsales@regalbeloit.com • www.hubcityinc.com



Hub City DuraLine® Bearing Units

Flange Blocks

Series FB120UR, FB150UR

100 SERIES 3 BOLT FLANGE BLOCK SETSCREW LOCK

Features

- Self-aligning replaceable bearing
- Pre-lubricated with lithium grease
- Steel retainers
- Anti-rotation pins
- Nitrile rubber seals with steel trash guards
- Precision bored housings

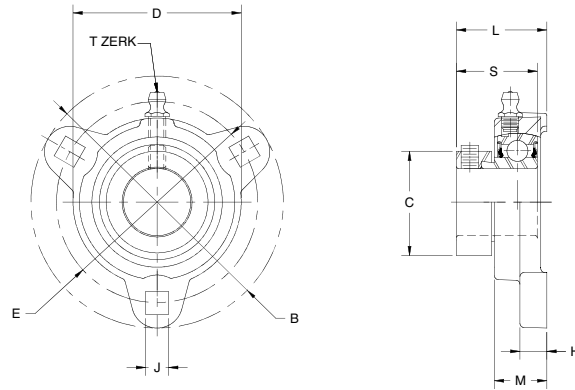

100 SERIES – 3 BOLT FLANGE BLOCKS – DUCTILE IRON – ECCENTRIC LOCK										
FB120UR										
SHAFT SIZE	B	C	D	E	H	J	L	M	S	WT. LBS
1/2, 5/8	3.1900	1.1020	2.0500	2.5000	0.3900	0.2800	1.2800	0.6900	1.1260	0.6
3/4	3.5600	1.2990	2.4400	2.8110	0.3900	0.3400	1.3500	0.7800	1.2200	0.8
7/8, 1	3.7500	1.4760	2.8300	3.0000	0.4700	0.3400	1.3300	0.7800	1.2200	0.8
1-1/8, 1-3/16, 1-1/4s	4.4400	1.7320	3.3100	3.5630	0.4700	0.4100	1.5600	0.8700	1.4050	1.1
1-1/4, 1-3/8, 1-7/16	4.8000	2.1650	3.4600	3.9370	0.5300	0.4100	1.7300	0.9400	1.5310	1.7

DuraLine Replacement Inserts

For 100 Series SetScrew Lock Use B250R, for 100 Series Eccentric Lock Use B220R

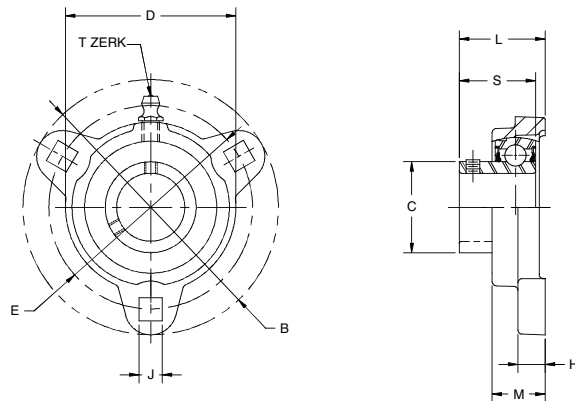

100 SERIES – 3 BOLT FLANGE BLOCKS – DUCTILE IRON – SETSCREW LOCK										
FB150UR (RELUBE)										
SHAFT SIZE	B	C	D	E	H	J	L	M	S	WT. LBS
1/2, 5/8	3.1900	0.9210	2.0500	2.5000	0.3900	0.2800	1.0200	0.6900	0.8660	0.6
3/4	3.5600	1.1420	2.4400	2.8110	0.3900	0.3400	1.1400	0.7800	0.9840	0.8
7/8, 1	3.7500	1.3390	2.8300	3.0000	0.4700	0.3400	1.1700	0.7800	1.0630	0.8
1-1/8, 1-3/16, 1-1/4s	4.4400	1.5870	3.3100	3.5630	0.4700	0.4100	1.3400	0.8700	1.1810	1.1
1-1/4, 1-3/8, 1-7/16	4.8000	1.8890	3.4600	3.9370	0.5300	0.4100	1.4500	0.9400	1.2600	1.7

For Load Ratings, See Page N-3
T-Zerk: 1/4-28 Taper

Dimensions shown are for reference only.
To order, specify type and bore size. Example:
FB250UR x 1-7/16

DOWNLOAD AVAILABLE CAD MODELS AT: WWW.HUBCITYINC.COM

Certified prints are available upon request

CALL: (605) 225-0360 • FAX: (605) 225-0567

Hub City DuraLine® Bearing Units

Flange Blocks

Features

- Self-aligning replaceable bearing
- Pre-lubricated with lithium grease
- Steel retainers
- Anti-rotation pins
- Nitrile rubber seals with steel trash guards
- Precision bored housings

Series FB230UR, FB260UR

200 SERIES 2 BOLT FLANGE BLOCK
ECCENTRIC LOCK

200 SERIES 2 BOLT FLANGE BLOCK
SETSCREW LOCK

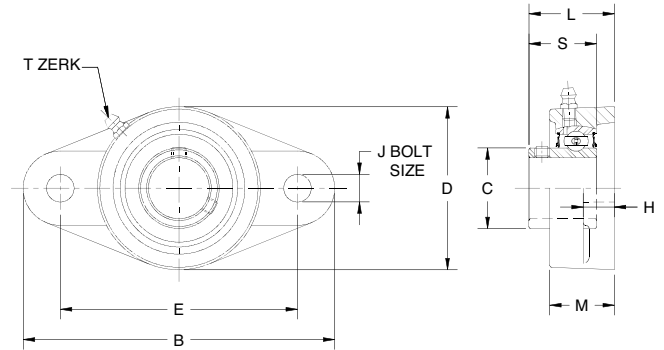
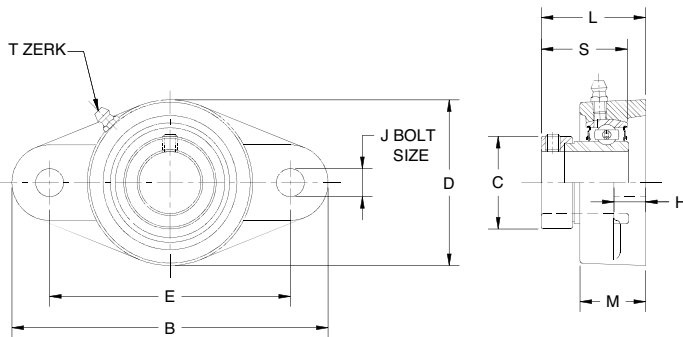

200 SERIES – 2 BOLT FLANGE BLOCKS – CAST IRON – ECCENTRIC LOCK										
FB230UR										
SHAFT SIZE	B	C	D	E	H	J	L	M	S	WT. LBS.
1/2, 5/8	4.4100	1.1000	2.3600	3.0000	0.4300	0.4100	1.5620	0.9800	1.1260	1.0
3/4	4.4100	1.3000	2.3600	3.5310	0.4300	0.4100	1.5080	0.9800	1.2200	1.3
7/8, 1	4.8800	1.4800	2.7600	3.8900	0.5100	0.4900	1.5510	1.0600	1.2200	1.9
1-1/8, 1-3/16, 1-1/4s	5.5500	1.7300	3.2700	4.5940	0.5100	0.4900	1.7950	1.1800	1.4060	2.7
1-1/4, 1-3/8, 1-7/16	6.1400	2.1700	3.7400	5.1250	0.5500	0.5500	1.9490	1.3400	1.5310	3.1
1-1/2	6.7300	2.2800	4.1300	5.6570	0.5500	0.5500	2.1930	1.5000	1.7200	3.6
1-5/8, 1-11/16, 1-3/4	7.0500	2.4800	4.3700	5.8430	0.5500	0.6300	2.2050	1.5700	1.7200	4.3
1-7/8, 1-15/16, 2S	7.4400	2.7200	4.5700	6.1890	0.5500	0.6300	2.2010	1.5700	1.7200	5.3
2, 2-3/16	8.5000	2.9900	5.2400	7.2520	0.8300	0.7100	2.4920	1.7300	1.8900	7.6

200 SERIES – 2 BOLT FLANGE BLOCKS – CAST IRON – SETSCREW LOCK										
FB260UR										
SHAFT SIZE	B	C	D	E	H	J	L	M	S	WT. LBS.
1/2, 5/8	4.4100	0.9200	2.3600	3.0000	0.4300	0.4100	1.3030	0.9800	0.8660	0.8
3/4	4.4100	1.1400	2.3600	3.5310	0.4300	0.4100	1.2830	0.9800	0.9840	1.0
7/8, 1	4.8800	1.3400	2.7600	3.8900	0.5100	0.4900	1.4020	1.0600	1.0630	1.4
1-1/8, 1-3/16, 1-1/4s	5.5500	1.5900	3.2700	4.5940	0.5100	0.4900	1.5790	1.1800	1.1810	1.9
1-1/4, 1-3/8, 1-7/16	6.1400	1.8900	3.7400	5.1250	0.5500	0.5500	1.7520	1.3400	1.2600	2.9
1-1/2	6.7300	2.2800	4.1300	5.6570	0.5500	0.5500	2.1930	1.5000	1.7200	3.9
1-5/8, 1-11/16, 1-3/4	7.0500	2.4800	4.3700	5.8430	0.5500	0.6300	2.0470	1.5700	1.7200	4.5
1-7/8, 1-15/16, 2S	7.4400	2.7200	4.5700	6.1890	0.5500	0.6300	2.1540	1.5700	1.7200	4.9
2, 2-3/16	8.5000	2.9900	5.2400	7.2520	0.8300	0.7100	2.3200	1.7300	1.8900	6.5

DuraLine Replacement Inserts

For 200 Series Setscrew Lock Use B250R, for 200 Series Eccentric Lock Use B220R, for 300 Series Setscrew Lock Use B350R

For Load Ratings, See Page N-3
T-Zerk: 1/4-28 Taper

Dimensions shown are for reference only.
To order, specify type and bore size. Example:
FB260UR x 1-7/16

DOWNLOAD AVAILABLE CAD MODELS AT: WWW.HUBCITYINC.COM

Certified prints are available upon request

EMAIL: hubsales@regalbeloit.com • www.hubcityinc.com



Hub City DuraLine® Bearing Units

Flange Blocks - Wide Inner Race

Series FB260DRW, FB230DRW

Features

- Ductile iron housings
- Higher strength and impact resistance for high shock loads
- Suitable to replace gray iron housed bearings
- Self-aligning replaceable bearing
- Pre-lubricated with lithium grease
- Steel retainers
- Anti-rotation pins
- Nitrile rubber seals with steel flingers
- Precision bored housings

200 SERIES 2 BOLT FLANGE BLOCK
ECCENTRIC LOCK – WIDE INNER RING

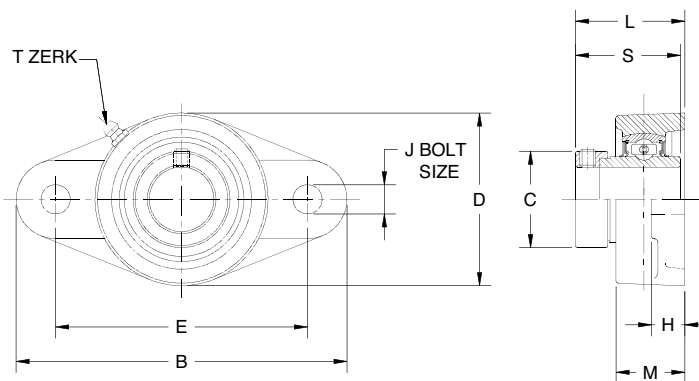

200 SERIES 2 BOLT FLANGE BLOCK
SETSCREW LOCK – WIDE INNER RING

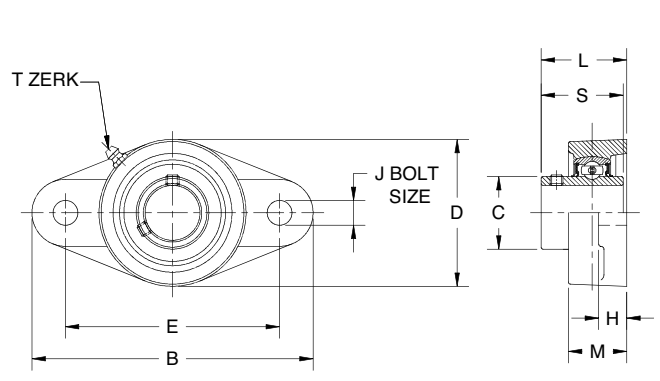

200 SERIES - 2 BOLT FLANGE BLOCKS - DUCTILE - ECCENTRIC LOCK - WIDE INNER RING										
FB230DRW										
SHAFT SIZE	B	C	D	E	H	J	L	M	S	WT. LBS.
3/4	4.4100	1.3000	2.3600	3.5310	0.4300	0.4130	1.7970	1.2600	1.7200	1.4
7/8, 1	4.8800	1.4800	2.7600	3.8900	0.5100	0.4920	1.8090	1.3200	1.7480	2.0
1-1/8, 1-3/16, 1-1/4s	5.5500	1.7300	3.2300	4.5940	0.5100	0.4920	1.9980	1.3800	1.9050	2.9
1-1/4, 1-3/8, 1-7/16	6.1400	2.1700	3.7400	5.1250	0.5900	0.5510	2.1150	1.4700	2.0160	3.3
1-1/2	6.7700	2.2800	4.1300	5.6570	0.5900	0.5510	2.3130	1.6900	2.2200	3.9
1-5/8, 1-11/16, 1-3/4	7.0500	2.4800	4.3700	5.8430	0.5900	0.6300	2.3060	1.7500	2.2200	4.6
1-7/8, 1-15/16, 2s	7.4400	2.7200	4.5600	6.1890	0.5900	0.6300	2.6260	1.8800	2.4680	5.8
2, 2-3/16	8.5000	2.9900	5.2400	7.2520	0.8300	0.7090	2.9680	2.0000	2.8110	8.1



200 SERIES - 2 BOLT FLANGE BLOCKS - DUCTILE - SETSCREW LOCK - WIDE INNER RING										
FB260DRW										
SHAFT SIZE	B	C	D	E	H	J	L	M	S	WT. LBS.
3/4, 20mm	4.4100	1.1420	2.3600	3.5310	0.4300	0.4130	1.4680	1.2600	1.2200	1.1
7/8, 1, 25mm	4.8800	1.3390	2.7600	3.8900	0.5100	0.4920	1.5230	1.3200	1.3390	1.5
1-1/8, 1-3/16, 1-1/4s, 30mm	5.5500	1.5910	3.2300	4.5940	0.5100	0.4920	1.6850	1.3800	1.5000	2.1
1-1/4, 1-3/8, 1-7/16, 35mm	6.1400	1.8660	3.7400	5.1250	0.5900	0.5510	1.8420	1.4700	1.6890	3.1
1-1/2, 40mm	6.7700	2.0750	4.1300	5.6570	0.5900	0.5510	2.1260	1.6900	1.9370	4.2
1-5/8, 1-11/16, 1-3/4, 45mm	7.0500	2.2480	4.3700	5.8430	0.5900	0.6300	2.1260	1.7500	1.9370	4.8
1-7/8, 1-15/16, 2s, 50mm	7.4400	2.4650	4.5600	6.1890	0.5900	0.6300	2.4090	1.8800	2.0310	5.2
2, 2-3/16, 55mm	8.5000	2.7760	5.2400	7.2520	0.8300	0.7090	2.5670	2.0000	2.1890	7.0



DuraLine Replacement Inserts

For 100 and 200 Series Setscrew Lock Use B250RW, for 100 and 200 Series Eccentric Lock Use B220RW

Dimensions shown are for reference only.

To order, specify type and bore size.

Example: FB260URW x 1-7/16

For Load Ratings, See Page N-3
T-Zerk: 1/4-28 Taper

DOWNLOAD AVAILABLE CAD MODELS AT: WWW.HUBCITYINC.COM

Certified prints are available upon request

CALL: (605) 225-0360 • FAX: (605) 225-0567

Hub City DuraLine® Bearing Units

Flange Blocks

Features

- Self-aligning replaceable bearing
- Pre-lubricated with lithium grease
- Steel retainers
- Anti-rotation pins
- Nitrile rubber seals with steel trash guards
- Precision bored housings

Series FB250UR, FB220UR

200 SERIES 4 BOLT FLANGE BLOCK ECCENTRIC LOCK

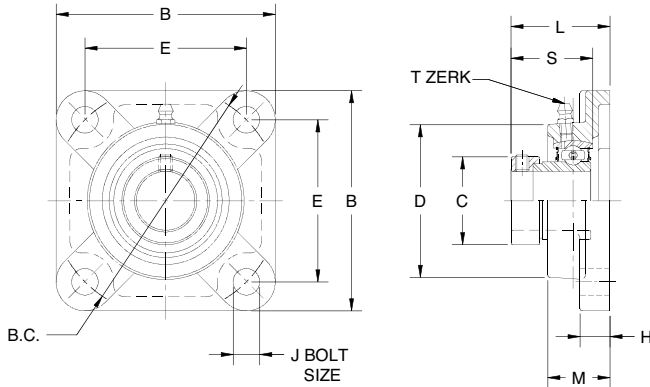

200 SERIES 4 BOLT FLANGE BLOCK SETSCREW LOCK

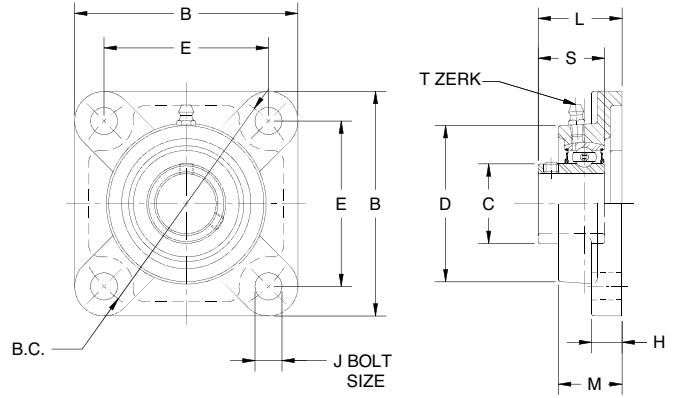

200 SERIES – 4 BOLT FLANGE BLOCKS – CAST IRON – ECCENTRIC LOCK											
FB220UR											
SHAFT SIZE	B	B.C.	C	D	E	H	J	L	M	S	WT. LBS.
1/2, 5/8	3.0000	3.0000	1.1000	2.0900	2.1200	0.4300	0.4500	1.4800	1.0000	1.1250	1.0
3/4	3.3800	3.5630	1.3000	2.3600	2.5200	0.4700	0.4700	1.5350	1.0000	1.2200	1.4
7/8, 1	3.7400	3.8980	1.4800	2.8000	2.7560	0.5500	0.4700	1.5550	1.0600	1.2200	1.8
1-1/8, 1-3/16, 1-1/4s	4.2500	4.6250	1.7300	3.1900	3.2680	0.5500	0.4700	1.7990	1.2200	1.4060	2.6
1-1/4, 1-3/8, 1-7/16	4.6100	5.1250	2.1700	3.6200	3.6220	0.6300	0.5500	1.9450	1.3400	1.5310	4.3
1-1/2	5.1200	5.6770	2.2800	4.0900	4.0160	0.6300	0.6300	2.1930	1.4200	1.7200	5.3
1-5/8, 1-11/16, 1-3/4	5.3900	5.8460	2.4800	4.2500	4.1340	0.7100	0.6300	2.2130	1.5000	1.7200	5.6
1-7/8, 1-15/16, 2S	5.6300	6.1810	2.7100	4.4500	4.3750	0.7100	0.6300	2.1930	1.5700	1.7200	6.5
2, 2-3/16	6.3800	7.2360	2.9900	4.9200	5.1180	0.7800	0.7500	2.4760	1.6900	1.9060	9.1



200 SERIES – 4 BOLT FLANGE BLOCKS – CAST IRON – SETSCREW LOCK											
FB250UR											
SHAFT SIZE	B	B.C.	C	D	E	H	J	L	M	S	WT. LBS.
1/2, 5/8	3.0000	3.0000	0.9200	2.0900	2.1260	0.4300	0.4500	1.2200	1.0000	0.8660	1.0
3/4	3.3800	3.5630	1.1400	2.3600	2.5200	0.4700	0.4700	1.3000	1.0000	0.9840	1.4
7/8, 1	3.7400	3.8980	1.3400	2.8000	2.7560	0.5500	0.4700	1.3980	1.0600	1.0630	1.8
1-1/8, 1-3/16, 1-1/4s	4.2500	4.6250	1.5900	3.1900	3.2680	0.5500	0.4700	1.5750	1.2200	1.2200	2.6
1-1/4, 1-3/8, 1-7/16	4.6100	5.1250	1.8900	3.6200	3.6220	0.6300	0.5500	1.6730	1.3400	1.2600	4.2
1-1/2	5.1200	5.6770	2.0900	4.0900	4.0160	0.6300	0.6300	1.8110	1.4200	1.3390	5.3
1-5/8, 1-11/16, 1-3/4	5.3900	5.8460	2.2500	4.2500	4.1340	0.7100	0.6300	2.0870	1.5000	1.6220	5.7
1-7/8, 1-15/16, 2S	5.6300	6.1810	2.4300	4.4500	4.3750	0.7100	0.6300	2.1500	1.5700	1.7130	6.6
2, 2-3/16	6.3800	7.2360	2.7200	4.9200	5.1180	0.7800	0.7500	2.3030	1.6900	1.7830	9.0

DuraLine Replacement Inserts

For 200 Series Setscrew Lock Use B250R, for 200 Series Eccentric Lock Use B220R, for 300 Series Setscrew Lock Use B350R

For Load Ratings, See Page N-3
T-Zerk: 1/4-28 Taper

Dimensions shown are for reference only.
To order, specify type and bore size. Example:
FB250UR x 1-7/16

DOWNLOAD AVAILABLE CAD MODELS AT: WWW.HUBCITYINC.COM

Certified prints are available upon request

EMAIL: hubsales@regalbeloit.com • www.hubcityinc.com



DuraLine® Bearings



Hub City DuraLine® Bearing Units

Flange Blocks - Wide Inner Race

Series FB220DRW, FB250DRW

Features

- Ductile iron housings
- Higher strength and impact resistance for high shock loads
- Suitable to replace gray iron housed bearings
- Self-aligning replaceable bearing
- Pre-lubricated with lithium grease
- Steel retainers
- Anti-rotation pins
- Nitrile rubber seals with steel flingers
- Precision bored housings

200 SERIES 4 BOLT FLANGE BLOCK
ECCENTRIC LOCK – WIDE INNER RING

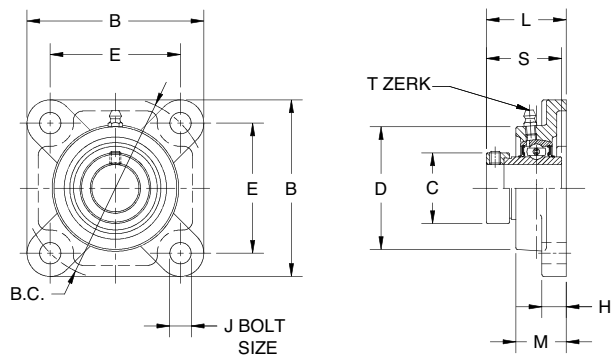

200 SERIES 4 BOLT FLANGE BLOCK
SETSCREW LOCK – WIDE INNER RING

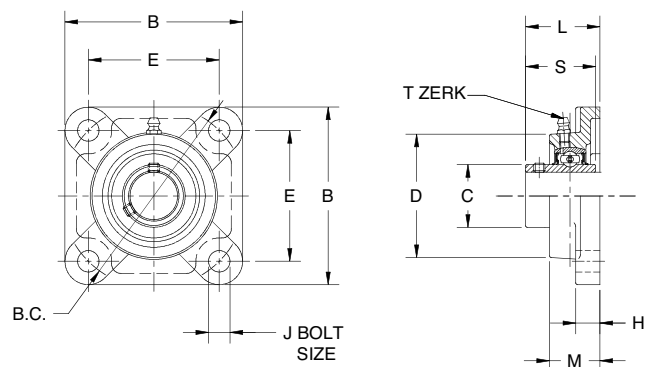

200 SERIES - 4 BOLT FLANGE BLOCKS - DUCTILE IRON - ECCENTRIC LOCK - WIDE INNER RING											
FB220DRW											
SHAFT SIZE	B	B.C.	C	D	E	H	J	L	M	S	WT. LBS.
3/4	3.3800	3.5630	1.3000	2.4000	2.5000	0.5900	0.4530	1.7910	1.1600	1.7200	1.7
7/8, 1	3.6600	3.8980	1.4800	2.7500	2.7500	0.5900	0.4530	1.8070	1.1800	1.7480	2.1
1-1/8, 1-3/16, 1-1/4s	4.1800	4.6250	1.7300	3.1500	3.2500	0.6300	0.5120	1.9720	1.2800	1.9050	2.9
1-1/4, 1-3/8, 1-7/16	4.5600	5.1250	2.1700	3.5400	3.6250	0.6700	0.5120	2.0980	1.3800	2.0160	3.9
1-1/2	5.0800	5.6560	2.2800	4.0200	4.0000	0.6700	0.5510	2.3200	1.5400	2.2200	4.9
1-5/8, 1-11/16, 1-3/4	5.3100	5.8340	2.4800	4.2500	4.1250	0.7100	0.6300	2.3200	1.5700	2.2200	5.8
1-7/8, 1-15/16, 2s	5.6300	6.1870	2.7100	4.4900	4.3750	0.7900	0.6300	2.6020	1.7700	2.4680	6.5
2, 2-3/16	6.3800	7.2480	2.9900	4.9600	5.1250	0.8300	0.6700	2.9370	1.9300	2.8110	9.0
2-1/4, 2-7/16	6.8900	7.9550	3.3100	5.3900	5.6250	0.8700	0.6700	3.1810	2.1100	3.0630	10.7



200 SERIES - 4 BOLT FLANGE BLOCKS - DUCTILE IRON - SETSCREW LOCK - WIDE INNER RING											
FB250DRW											
SHAFT SIZE	B	B.C.	C	D	E	H	J	L	M	S	WT. LBS.
3/4, 20mm	3.3800	3.5630	1.1420	2.4000	2.5000	0.5900	0.4530	1.4860	1.1600	1.2200	1.5
7/8, 1, 25mm	3.6600	3.8980	1.3390	2.7500	2.7500	0.5900	0.4530	1.5230	1.1800	1.3390	1.9
1-1/8, 1-3/16, 1-1/4s, 30mm	4.1800	4.6250	1.5910	3.1500	3.2500	0.6300	0.5120	1.6610	1.2800	1.5000	2.8
1-1/4, 1-3/8, 1-7/16, 35mm	4.5600	5.1250	1.8660	3.5400	3.6250	0.6700	0.5120	1.8260	1.3800	1.6890	4.4
1-1/2, 40mm	5.0800	5.6560	2.0750	4.0200	4.0000	0.6700	0.5510	2.1330	1.5400	1.9370	5.6
1-5/8, 1-11/16, 1-3/4, 45mm	5.3100	5.8340	2.2480	4.2500	4.1250	0.7100	0.6300	2.1330	1.5700	1.9370	6.0
1-7/8, 1-15/16, 2s, 50mm	5.6300	6.1870	2.4650	4.4900	4.3750	0.7900	0.6300	2.3860	1.7700	2.0310	7.1
2, 2-3/16, 55mm	6.3800	7.2480	2.7760	4.9600	5.1250	0.8300	0.6700	2.5350	1.9300	2.1890	9.5
2-1/4, 2-7/16, 60mm	6.8900	7.9550	3.0590	5.3900	5.6250	0.8700	0.6700	2.8860	2.1100	2.5630	12.4



DuraLine Replacement Inserts
For 100 and 200 Series Setscrew
Lock Use B250RW, for 100 and
200 Series Eccentric Lock Use
B220RW

For Load Ratings, See Page N-3
T-Zerk: 1/4-28 Taper

Dimensions shown are for
reference only. To order,
specify type and bore size.
Example: FB250DRW x 1-7/16

DOWNLOAD AVAILABLE CAD MODELS AT: WWW.HUBCITYINC.COM

Certified prints are available upon request

CALL: (605) 225-0360 • FAX: (605) 225-0567

Hub City DuraLine® Bearing Units

Cast Iron Flange Cartridge

Series FC250URW

- Relube type. Prelubricated at factory
- Setscrew locking
- Self-aligning replacement bearing
- Nitrile rubber seals with steel trash guard
- Precision bored Cast Iron Housing

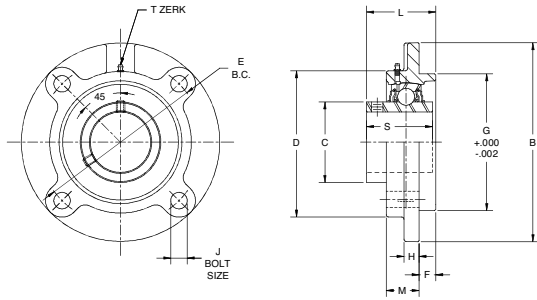

SHAFT SIZE	FC250URW - FLANGE CARTRIDGE - CAST IRON - SETSCREW - WIDE INNER RING											WT. LBS.
	B	C	D	E	F	G	H	J	L	M	S	
1-1/8, 1-3/16, 1-1/4s, 30mm	4.3700	1.5910	3.2500	3.6220	0.2500	3.0000	0.3700	0.3740	1.5200	0.9400	1.2680	3.3
1-1/4, 1-3/8, 1-7/16, 35mm	5.0000	1.8660	3.6200	4.1340	0.3700	3.3740	0.3700	0.4720	1.6800	0.8700	1.3150	3.9
1-1/2, 40mm	5.2400	2.0750	3.8800	4.3700	0.4400	3.6220	0.4300	0.4720	1.9800	1.0200	1.5430	4.1
1-5/8, 1-11/16, 1-3/4, 45mm	6.1000	2.2480	4.2500	5.1180	0.4700	4.2520	0.4700	0.5510	1.9800	0.8700	1.4170	5.5
1-7/8, 1-15/16, 2s, 50mm	6.1000	2.4650	4.5000	5.1180	0.4700	4.2520	0.4300	0.5510	2.0700	0.9800	1.5980	6.1
2, 2-3/16, 55mm	6.3800	2.7760	4.8800	5.3940	0.6300	4.5000	0.5100	0.5510	2.1800	0.9800	1.5900	8.9
2-1/4, 2-7/16, 60mm	7.0900	3.0590	5.3800	5.9840	0.8700	5.0000	0.6300	0.6300	2.5900	1.0200	1.7200	11.3

Part Numbers are specified by "FC250URW" and Bore Size. Example: FC250URW x 1-1/2.

Three-Bolt Flange Bracket Bearings

Features

- Reliable Performance
- Economical Durability
- Cast Iron Housings
- Wide Inner Race
- Self Aligning Replaceable Bearing
- Setscrew Lock Inserts
- Pre-lubricated with Lithium Grease
- Steel Retainers
- Anti-rotation pins
- Nitrile Rubber Seals with Steel Flingers
- Precision Bored Housings

FR250URW DURALINE 3-BOLT FLANGE BRACKET

Series FR250URW

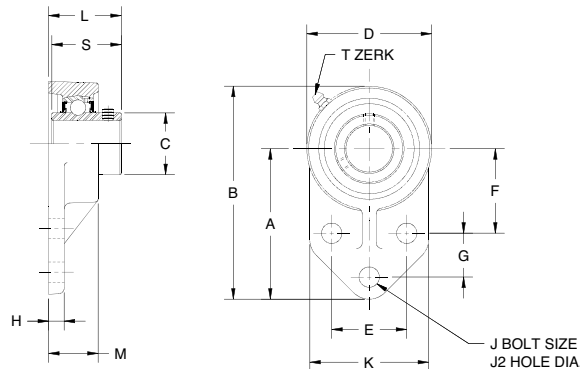

200 SERIES - 3 BOLT FLANGE BRACKETS - CAST IRON - SETSCREW LOCK - WIDE INNER RING								
FR250URW								
SHAFT SIZE	A	B	C	D	E	F	G	H
1/2, 5/8, 3/4, 20mm	3.0000	4.2500	1.1420	2.5000	1.5000	1.6880	0.8750	0.3100
7/8, 1, 25mm	3.3800	4.7500	1.3390	2.7500	1.6250	1.8120	1.1250	0.3800
1-1/8, 1-3/16, 1-1/4s, 30mm	3.7500	5.3800	1.5910	3.2500	1.8750	2.0630	1.2500	0.3800
1-1/4, 1-3/8, 1-7/16, 35mm	4.2500	6.1200	1.8660	3.7500	2.0000	2.3750	1.2500	0.5000
1-1/2, 40mm	4.5000	6.4400	2.0750	3.9400	2.0000	2.3750	1.6250	0.6300
1-5/8, 1-11/16, 1-3/4, 45mm	4.7500	6.8700	2.2480	4.1800	2.1250	2.5620	4.6880	0.7200
1-15/16, 2S, 50mm	5.1800	7.5000	2.4650	4.6500	2.7500	2.9370	1.6250	0.5000



200 SERIES - 3 BOLT FLANGE BRACKETS - CAST IRON - SETSCREW LOCK - WIDE INNER RING							
FR250URW							
SHAFT SIZE	J	J2	K	L	M	S	WT LBS
1/2, 5/8, 3/4, 20mm	0.3750	0.3940	2.3800	1.3430	1.0000	1.2200	1.5
7/8, 1, 25mm	0.3750	0.3940	2.5000	1.4370	1.1200	1.3380	1.9
1-1/8, 1-3/16, 1-1/4s, 30mm	0.3750	0.3940	2.7500	1.6100	1.2500	1.5000	2.2
1-1/4, 1-3/8, 1-7/16, 35mm	0.5000	0.5510	3.2500	1.8270	1.4400	1.6890	3.6
1-1/2, 40mm	0.5000	0.5510	3.0600	2.0160	1.4100	1.9370	4.6
1-5/8, 1-11/16, 1-3/4, 45mm	0.5000	0.5510	3.1300	2.0160	1.5000	1.9370	5.0
1-15/16, 2S, 50mm	0.5000	0.5510	4.0000	2.1100	1.5000	2.0310	5.7



DuraLine Replacement Inserts
For 100 and 200 Series Setscrew
Lock Use B250RW, for 100 and
200 Series
Eccentric Lock Use B220RW

For Load Ratings, See Page N-3

T-Zerk: 1/4-28 Taper

DOWNLOAD AVAILABLE CAD MODELS AT: WWW.HUBCITYINC.COM

Certified prints are available upon request

Dimensions shown are for reference only.

To order, specify type and bore size. Example:

FR250URW x 1-7/16

Hub City DuraLine® Bearing Units

Standard Slot Take-Up Units

Series TU220UR, TU250UR

TU220UR Standard Slot Take-Up Units

- Relube type. Prelubricated at factory
- Eccentric locking collar
- Self-aligning replaceable bearing
- Nitrile rubber seals with steel trash guard
- Precision bored Cast Iron housing

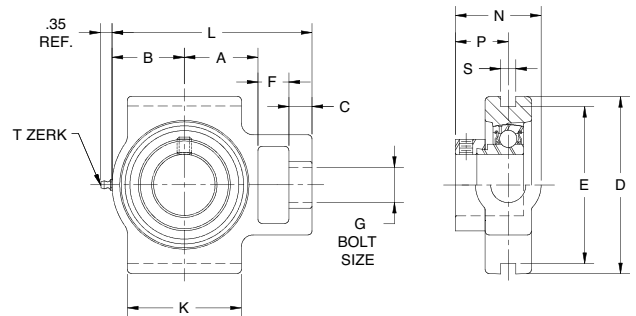

NOTE: BEARINGS WITH ECCENTRIC LOCKING COLLARS ARE NOT RECOMMENDED FOR USE IN REVERSING APPLICATIONS.

SHAFT SIZE	USE WITH FRAME NO. ★	DIMENSIONS													WT. LBS.
		A	B	C	D	E	F	G	J	K	L	N	P	S§	
3/4	3 thru 9T200BC	1.2900	1.2600	0.4000	3.5000	3.0000	0.6300	0.7500	1.8900	1.7300	3.9300	1.6800	0.9450	0.3110	1.6
7/8, 1	3 thru 9T200BC	1.2900	1.3800	0.4000	3.5000	3.0000	0.6300	0.7500	1.8900	1.9300	4.0500	1.6600	0.9250	0.3110	1.9
1-1/8, 1-3/16, 1-1/4S	3 thru 12T200DE	1.6100	1.5800	0.5100	4.0200	3.5040	0.6300	0.8700	2.1300	2.3600	4.6800	1.9000	1.0910	0.3110	2.5
1-1/4, 1-3/8, 1-7/16	3 thru 12T200DE	1.6900	1.7000	0.5100	4.0200	3.5040	0.7500	0.8700	2.1300	2.6400	5.0000	2.0100	1.1970	0.3110	2.9
1-1/2	3 thru 18T200FH	1.8900	1.8500	0.6300	4.4900	4.0000	0.7500	1.1400	2.6400	2.9500	5.4700	2.2700	1.3660	0.3110	4.1
1-5/8, 1-3/4, 1-11/16	3 thru 18T200FH	2.0500	2.0000	0.6300	4.4900	4.0000	0.7500	1.1400	2.6400	3.1100	5.7800	2.2500	1.3460	0.3110	4.6
1-15/16, 2	3 thru 18T200FH	2.2000	2.1300	0.6300	4.4900	4.0000	0.7500	1.1400	2.6400	3.3100	6.0600	2.2300	1.3270	0.3110	4.6
2-3/16, 2-1/4	9 thru 18T200JK	2.3800	2.3300	0.7500	5.7500	5.1260	1.0000	1.3800	3.2700	3.7000	6.8100	2.5500	1.4920	0.3110	8.3
2-7/16	9 thru 18T200JK	2.7000	2.8700	0.7500	5.7500	5.1260	1.0000	1.3800	3.2700	4.0600	7.6700	2.5700	1.5040	0.3110	8.6

Part Numbers are specified by "TU220UR" and Bore Size. Example: TU220UR x 1-1/2.
 ★ Take-Up Frames shown on page M-33.
 § Take-Up Units with wider slots are shown on page N-19.

For Load Ratings, see page N-3.
 For replacement inserts use B220R Bearing Inserts

TU250UR Standard Slot Take-Up Units

- Relube type. Prelubricated at factory
- Setscrew locking
- Self-aligning replaceable bearing
- Nitrile rubber seals with steel trash guard
- Precision bored Cast Iron housing

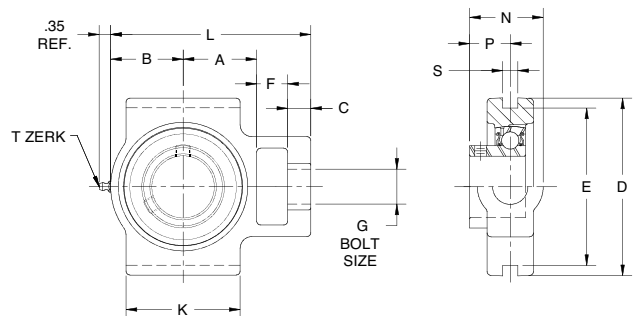

SHAFT SIZE	USE WITH FRAME NO. ★	DIMENSIONS													WT. LBS.
		A	B	C	D	E	F	G	J	K	L	N	P	S§	
3/4	3 thru 9T200BC	1.2900	1.2600	0.4000	3.5000	3.0000	0.6300	0.7500	1.8900	1.7300	3.9300	1.4400	0.7090	0.3110	1.6
7/8, 1	3 thru 9T200BC	1.2900	1.3800	0.4000	3.5000	3.0000	0.6300	0.7500	1.8900	1.9300	4.0500	1.5000	0.7680	0.3110	1.9
1-1/8, 1-3/16, 1-1/4S	3 thru 12T200DE	1.6100	1.5800	0.5100	4.0200	3.5040	0.6300	0.8700	2.1300	2.3600	4.6800	1.6800	0.8660	0.3110	2.5
1-1/4, 1-3/8, 1-7/16	3 thru 12T200DE	1.6900	1.7000	0.5100	4.0200	3.5040	0.7500	0.8700	2.1300	2.6400	5.0000	1.7400	0.9250	0.3110	2.9
1-1/2	3 thru 18T200FH	1.8900	1.8500	0.6300	4.4900	4.0000	0.7500	1.1400	2.6400	2.9500	5.4700	3.1700	0.9840	0.3110	4.1
1-5/8, 1-3/4, 1-11/16	3 thru 18T200FH	2.0500	2.0000	0.6300	4.4900	4.0000	0.7500	1.1400	2.6400	3.1100	5.7800	2.1300	1.2200	0.3110	4.6
1-15/16, 2	3 thru 18T200FH	2.2000	2.1300	0.6300	4.4900	4.0000	0.7500	1.1400	2.6400	3.3100	6.0600	2.1900	1.2830	0.3110	4.6
2-3/16, 2-1/4	9 thru 18T200JK	2.3800	2.3300	0.7500	5.7500	5.1260	1.0000	1.3800	3.2700	3.7000	6.8100	2.3800	1.3190	0.3110	8.3
2-7/16	9 thru 18T200JK	2.7000	2.8700	0.7500	5.7500	5.1260	1.0000	1.3800	3.2700	4.0600	7.6700	2.5900	1.5280	0.3110	8.6

Part Numbers are specified by "TU250UR" and Bore Size. Example: TU250UR x 1-1/2.
 ★ Take-Up Frames shown on page M-33.
 § Take-Up Units with wider slots are shown on page N-19.
 For Load Ratings, see page N-3.
 For replacement inserts use B220R Bearing Inserts

¶ DIMENSIONS SHOWN ARE FOR REFERENCE ONLY.

DOWNLOAD AVAILABLE CAD MODELS AT: WWW.HUBCITYINC.COM

Certified prints are available upon request

CALL: (605) 225-0360 • FAX: (605) 225-0567

Hub City DuraLine® Bearing Units

Standard Slot Take-Up Units

Series TU220URW, TU250URW

TU220URW Standard Slot Take-Up Units

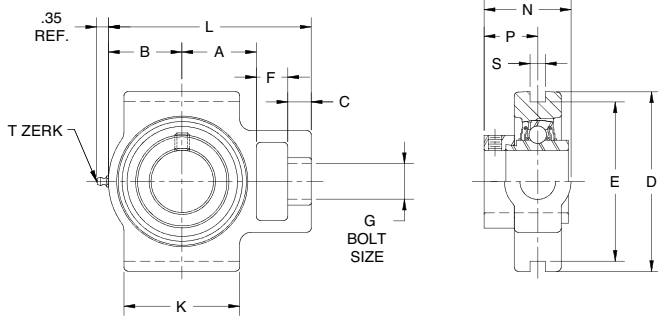

- Relube type. Prelubricated at factory
- Eccentric locking collar
- Self-aligning replaceable bearing
- Nitrile rubber seals with steel trash guard
- Precision bored Cast Iron housing
- Wide inner race

NOTE: BEARINGS WITH ECCENTRIC LOCKING COLLARS ARE NOT RECOMMENDED FOR USE IN REVERSING APPLICATIONS.

SHAFT SIZE	USE WITH FRAME NO. ★	DIMENSIONS													WT. LBS.
		A	B	C	D	E	F	G	J	K	L	N	P	§§	
3/4	3 thru 9T200BC	1.2900	1.2600	0.4000	3.5000	3.0000	0.6300	0.7500	1.8900	1.7300	3.9300	1.7800	1.0490	0.3110	1.6
7/8, 1	3 thru 9T200BC	1.2900	1.3800	0.4000	3.5000	3.0000	0.6300	0.7500	1.8900	1.9300	4.0500	1.7900	1.0610	0.3110	1.9
1-1/8, 1-3/16, 1-1/4S	3 thru 12T200DE	1.6100	1.5800	0.5100	4.0200	3.5040	0.6300	0.8700	2.1300	2.3600	4.6800	2.0000	1.1870	0.3110	2.5
1-1/4, 1-3/8, 1-7/16	3 thru 12T200DE	1.6900	1.7000	0.5100	4.0200	3.5040	0.7500	0.8700	2.1300	2.6400	5.0000	2.0800	1.2740	0.3110	2.9
1-1/2	3 thru 18T200FH	1.8900	1.8500	0.6300	4.4900	4.0000	0.7500	1.1400	2.6400	2.9500	5.4700	2.2800	1.3760	0.3110	4.1
1-5/8, 1-3/4, 1-11/16	3 thru 18T200FH	2.0500	2.0000	0.6300	4.4900	4.0000	0.7500	1.1400	2.6400	3.1100	5.7800	2.2800	1.3760	0.3110	4.6
1-15/16, 2	3 thru 18T200FH	2.2000	2.1300	0.6300	4.4900	4.0000	0.7500	1.1400	2.6400	3.3100	6.0600	2.4100	1.5000	0.3110	4.6
2-3/16, 2-1/4	9 thru 18T200JK	2.3800	2.3300	0.7500	5.7500	5.1260	1.0000	1.3800	3.2700	3.7000	6.8100	2.7800	1.7170	0.3110	8.3
2-7/16	9 thru 18T200JK	2.7000	2.8700	0.7500	5.7500	5.1260	1.0000	1.3800	3.2700	4.0600	7.6700	2.9100	1.8440	0.3110	8.6

Part Numbers are specified by "TU220URW" and Bore Size. Example: TU220URW x 1-1/2.

For Load Ratings, see page N-3

★ Take-Up Frames shown on page M-33.

Bearing protrudes beyond edge of housing.

§ Take-Up Units with wider slots are shown on page N-20.

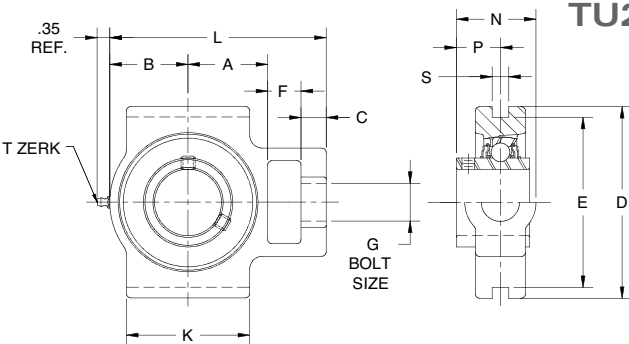

TU250URW Standard Slot Take-Up Units

- Relube type. Prelubricated at factory
- Setscrew locking
- Self-aligning replaceable bearing
- Nitrile rubber seals with steel trash guard
- Precision bored Cast Iron housing
- Wide inner race

SHAFT SIZE	USE WITH FRAME NO. ★	DIMENSIONS													WT. LBS.
		A	B	C	D	E	F	G	J	K	L	N	P	§§	
3/4, 20mm	3 thru 9T200BC	1.2900	1.2600	0.4000	3.5000	3.0000	0.6300	0.7500	1.8900	1.7300	3.9300	1.4500	0.7200	0.3110	1.6
7/8, 1, 25mm	3 thru 9T200BC	1.2900	1.3800	0.4000	3.5000	3.0000	0.6300	0.7500	1.8900	1.9300	4.0500	1.5000	0.7760	0.3110	1.9
1-1/8, 1-3/16, 1-1/4S, 30mm	3 thru 12T200DE	1.6100	1.5800	0.5100	4.0200	3.5040	0.6300	0.8700	2.1300	2.3600	4.6800	1.6800	0.8740	0.3110	2.5
1-1/4, 1-3/8, 1-7/16, 35mm	3 thru 12T200DE	1.6900	1.7000	0.5100	4.0200	3.5040	0.7500	0.8700	2.1300	2.6400	5.0000	1.8100	1.0000	0.3110	2.9
1-1/2, 40mm	3 thru 18T200FH	1.8900	1.8500	0.6300	4.4900	4.0000	0.7500	1.1400	2.6400	2.9500	5.4700	2.1000	1.1890	0.3110	4.1
1-5/8, 1-3/4, 1-11/16, 45mm	3 thru 18T200FH	2.0500	2.0000	0.6300	4.4900	4.0000	0.7500	1.1400	2.6400	3.1100	5.7800	2.1000	1.1890	0.3110	4.6
1-15/16, 2, 50mm	3 thru 18T200FH	2.2000	2.1300	0.6300	4.4900	4.0000	0.7500	1.1400	2.6400	3.3100	6.0600	2.1900	1.2830	0.3110	4.6
2-3/16, 2-1/4, 55mm	9 thru 18T200JK	2.3800	2.3300	0.7500	5.7500	5.1260	1.0000	1.3800	3.2700	3.7000	6.8100	2.3800	1.3150	0.3110	8.3
2-7/16, 60mm	9 thru 18T200JK	2.7000	2.8700	0.7500	5.7500	5.1260	1.0000	1.3800	3.2700	4.0600	7.6700	2.6300	1.5630	0.3110	8.6

Part Numbers are specified by "TU250URW" and Bore Size. Example: TU250URW x 1-1/2.

For Load Ratings, see page N-3

★ Take-Up Frames shown on page M-33.

For replacement inserts use YW250 Bearing Inserts

§ Take-Up Units with wider slots are shown on page N-20.

DOWNLOAD AVAILABLE CAD MODELS AT: WWW.HUBCITYINC.COM

Certified prints are available upon request

⚠ DIMENSIONS SHOWN ARE FOR REFERENCE ONLY.

EMAIL: hubsales@regalbeloit.com • www.hubcityinc.com



Hub City DuraLine® Bearing Units

Wide Slot Take-Up Units

Series WSTU220UR, WSTU250UR

WSTU220UR Wide Slot Take-Up Units

- Relube type. Prelubricated at factory
- Eccentric locking collar
- Self-aligning replaceable bearing
- Nitrile rubber seals with steel trash guard
- Precision bored Cast Iron housing

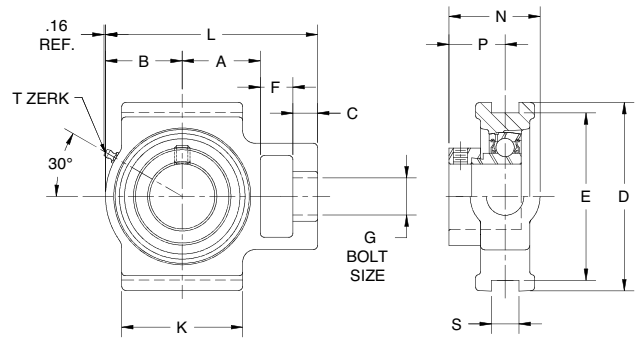

NOTE: BEARINGS WITH ECCENTRIC LOCKING COLLARS ARE NOT RECOMMENDED FOR USE IN REVERSING APPLICATIONS.

SHAFT SIZE	USE WITH FRAME NO.	DIMENSIONS													WT. LBS.
		A	B	C	D	E	F	G	J	K	L	N	P	S§	
3/4	3 Thru 9TWS200BC	1.3300	1.3400	0.4000	3.5000	3.0000	0.6300	0.7500	2.0000	2.0000	3.8600	1.5800	0.9450	1.2200	1.6
7/8, 1	3 Thru 9TWS200BC	1.4100	1.3800	0.4000	3.5000	3.0000	0.6300	0.7500	2.0000	2.0000	3.9800	1.5600	0.9250	1.2200	1.9
1-1/8, 1-3/16, 1-1/4S	3 Thru 12TWS200DE	1.7300	1.6900	0.4000	4.0200	3.5040	0.6300	0.8700	2.2000	2.2500	4.6100	1.8200	1.0910	1.4060	2.5
1-1/4, 1-3/8, 1-7/16	3 Thru 12TWS200DE	1.9300	2.0100	0.5100	4.0200	3.5040	0.6300	0.8700	2.5200	2.5200	5.2400	2.6600	1.1970	1.5310	2.9
1-1/2	3 Thru 18TWS200FH	2.1200	2.1700	0.6300	4.4900	4.0000	0.7500	1.1400	3.2700	3.2700	5.8300	2.3300	1.3660	0.6890	4.1
1-5/8, 1-3/4, 1-11/16	3 Thru 18TWS200FH	2.0500	2.2400	0.6300	4.4900	4.0000	0.7500	1.1400	3.2700	3.2700	5.8300	2.3100	1.3460	0.6890	4.6
1-15/16, 2	3 Thru 18TWS200FH	2.1600	2.3300	0.6300	4.4900	4.0000	0.7500	1.1400	3.2700	3.3800	6.0300	2.2900	1.3270	0.6890	4.8
2-3/16, 2-1/4	9 Thru 18TWS200JK	2.4400	2.5600	0.7500	5.7500	5.1260	0.9800	1.3800	4.0200	3.7400	6.8900	2.7500	1.4920	1.0630	8.3
2-7/16	9 Thru 18TWS200JK	2.6800	2.9500	0.7500	5.7500	5.1260	1.2600	1.3800	4.0200	4.0200	7.8000	2.7700	1.5040	1.0630	8.8

Part Numbers are specified by "WSTU220UR" and Bore Size. Example: WSTU220UR x 3/4.

§ Take-Up Units with narrower slots are shown on page M-24.

For replacement inserts use B220R Bearing Inserts

For Load Ratings, see page N-3.

WSTU250UR Wide Slot Take-Up Units

- Relube type. Prelubricated at factory
- Setscrew locking
- Self-aligning replaceable bearing
- Nitrile rubber seals with steel trash guard
- Precision bored Cast Iron housing

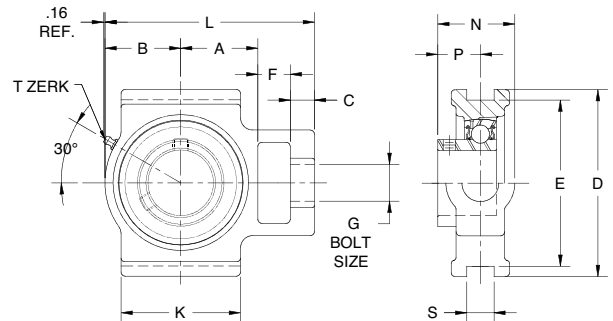

SHAFT SIZE	USE WITH FRAME NO.	DIMENSIONS													WT. LBS.
		A	B	C	D	E	F	G	J	K	L	N	P	S§	
3/4	3 Thru 9TWS200BC	1.3300	1.3400	0.4000	3.5000	3.0000	0.6300	0.7500	2.0000	2.0000	3.8600	1.3400	0.7090	1.2200	1.6
7/8, 1	3 Thru 9TWS200BC	1.4100	1.3800	0.4000	3.5000	3.0000	0.6300	0.7500	2.0000	2.0000	3.9800	1.4000	0.7680	1.2200	1.9
1-1/8, 1-3/16, 1-1/4S	3 Thru 12TWS200DE	1.7300	1.6900	0.4000	4.0200	3.5040	0.6300	0.8700	2.2000	2.2500	4.6100	1.6000	0.8660	1.4060	2.5
1-1/4, 1-3/8, 1-7/16	3 Thru 12TWS200DE	1.9300	2.0100	0.5100	4.0200	3.5040	0.6300	0.8700	2.5200	2.5200	5.2400	1.6600	0.9250	1.5310	2.9
1-1/2	3 Thru 18TWS200FH	2.1200	2.1700	0.6300	4.4900	4.0000	0.7500	1.1400	3.2700	3.2700	5.8300	1.9500	0.9840	0.6890	4.1
1-5/8, 1-3/4, 1-11/16	3 Thru 18TWS200FH	2.0500	2.2400	0.6300	4.4900	4.0000	0.7500	1.1400	3.2700	3.2700	5.8300	2.1400	1.2200	0.6890	4.6
1-15/16, 2	3 Thru 18TWS200FH	2.1600	2.3300	0.6300	4.4900	4.0000	0.7500	1.1400	3.2700	3.3800	6.0300	2.2000	1.2830	0.6890	4.8
2-3/16, 2-1/4	9 Thru 18TWS200JK	2.4400	2.5600	0.7500	5.7500	5.1260	0.9800	1.3800	4.0200	3.7400	6.8900	2.5800	1.3190	1.0630	8.3
2-7/16	9 Thru 18TWS200JK	2.6800	2.9500	0.7500	5.7500	5.1260	1.2600	1.3800	4.0200	4.0200	7.8000	2.9100	1.5280	1.0630	8.8

Part Numbers are specified by "WSTU250UR" and Bore Size. Example: WSTU250UR x 3/4.

§ Take-Up Units with narrower slots are shown on page M-24.

For replacement inserts use B250R Bearing Inserts

For Load Ratings, see page N-3.

¶ DIMENSIONS SHOWN ARE FOR REFERENCE ONLY.

DOWNLOAD AVAILABLE CAD MODELS AT: WWW.HUBCITYINC.COM

Certified prints are available upon request

CALL: (605) 225-0360 • FAX: (605) 225-0567

Hub City DuraLine® Bearing Units

Wide Slot Take-Up Units

Series WSTU220URW, WSTU250URW

WSTU220URW Wide Slot Take-Up Units

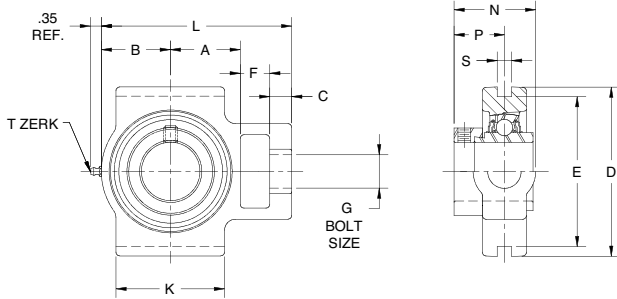

- Relube type. Prelubricated at factory
- Eccentric locking collar
- Self-aligning replaceable bearing
- Nitrile rubber seals with steel trash guard
- Precision bored Cast Iron housing

NOTE: BEARINGS WITH ECCENTRIC LOCKING COLLARS ARE NOT RECOMMENDED FOR USE IN REVERSING APPLICATIONS.

SHAFT SIZE	USE WITH FRAME NO.	DIMENSIONS											WT. LBS.		
		A	B	C	D	E	F	G	J	K	L	N		P	S§
3/4	3 Thru 9TWS200BC	1.3300	1.3400	0.4000	3.5000	3.0000	0.6300	0.7500	2.0000	2.0000	3.8600	1.6800	1.0490	1.2200	1.6
7/8, 1	3 Thru 9TWS200BC	1.4100	1.3800	0.4000	3.5000	3.0000	0.6300	0.7500	2.0000	2.0000	3.9800	1.6900	1.0610	1.2200	1.9
1-1/8, 1-3/16, 1-1/4S	3 Thru 12TWS200DE	1.7300	1.6900	0.4000	4.0200	3.5040	0.6300	0.8700	2.2000	2.2500	4.6100	1.9200	1.1870	1.4060	2.5
1-1/4, 1-3/8, 1-7/16	3 Thru 12TWS200DE	1.9300	2.0100	0.5100	4.0200	3.5040	0.6300	0.8700	2.5200	2.5200	5.2400	2.0000	1.2740	1.5310	2.9
1-1/2	3 Thru 18TWS200FH	2.1200	2.1700	0.6300	4.4900	4.0000	0.7500	1.1400	3.2700	3.2700	5.8300	2.3400	1.3760	0.6890	4.1
1-5/8, 1-3/4, 1-11/16	3 Thru 18TWS200FH	2.0500	2.2400	0.6300	4.4900	4.0000	0.7500	1.1400	3.2700	3.2700	5.8300	2.3400	1.3760	0.6890	4.6
1-15/16, 2	3 Thru 18TWS200FH	2.1600	2.3300	0.6300	4.4900	4.0000	0.7500	1.1400	3.2700	3.3800	6.0300	2.4700	1.5000	0.6890	4.8
2-3/16, 2-1/4	9 Thru 18TWS200JK	2.4400	2.5600	0.7500	5.7500	5.1260	0.9800	1.3800	4.0200	3.7400	6.8900	2.9800	1.7170	1.0630	8.3
2-7/16	9 Thru 18TWS200JK	2.6800	2.9500	0.7500	5.7500	5.1260	1.2600	1.3800	4.0200	4.0200	7.8000	3.1100	1.8440	1.0630	8.8

Part Numbers are specified by "WSTU220URW" and Bore Size. Example: WSTU220URW x 3/4.

- § Take-Up Units with narrower slots are shown on page M-39.
- For Load Ratings, see page N-3.

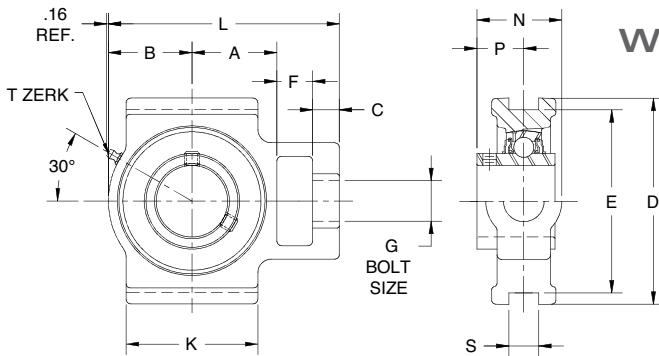

WSTU250URW Wide Slot Take-Up Units

- Relube type. Prelubricated at factory
- Setscrew locking
- Self-aligning replaceable bearing
- Nitrile rubber seals with steel trash guard
- Precision bored Cast Iron housing

SHAFT SIZE	USE WITH FRAME NO.	DIMENSIONS											WT. LBS.		
		A	B	C	D	E	F	G	J	K	L	N		P	S§
3/4, 20mm	3 Thru 9TWS200BC	1.3300	1.3400	0.4000	3.5000	3.0000	0.6300	0.7500	2.0000	2.0000	3.8600	1.3500	0.7200	1.2200	1.6
7/8, 1, 25mm	3 Thru 9TWS200BC	1.4100	1.3800	0.4000	3.5000	3.0000	0.6300	0.7500	2.0000	2.0000	3.9800	1.4100	0.7760	1.2200	1.9
1-1/8, 1-3/16, 1-1/4S, 30mm	3 Thru 12TWS200DE	1.7300	1.6900	0.4000	4.0200	3.5040	0.6300	0.8700	2.2000	2.2500	4.6100	1.6000	0.8740	1.4060	2.5
1-1/4, 1-3/8, 1-7/16, 35mm	3 Thru 12TWS200DE	1.9300	2.0100	0.5100	4.0200	3.5040	0.6300	0.8700	2.5200	2.5200	5.2400	1.7300	1.0000	1.5310	2.9
1-1/2, 40mm	3 Thru 18TWS200FH	2.1200	2.1700	0.6300	4.4900	4.0000	0.7500	1.1400	3.2700	3.2700	5.8300	2.1500	1.1890	0.6890	4.1
1-5/8, 1-3/4, 1-11/16, 45mm	3 Thru 18TWS200FH	2.0500	2.2400	0.6300	4.4900	4.0000	0.7500	1.1400	3.2700	3.2700	5.8300	2.1500	1.1890	0.6890	4.6
1-15/16, 2, 50mm	3 Thru 18TWS200FH	2.1600	2.3300	0.6300	4.4900	4.0000	0.7500	1.1400	3.2700	3.3800	6.0300	2.2500	1.2830	0.6890	4.8
2-3/16, 2-1/4, 55mm	9 Thru 18TWS200JK	2.4400	2.5600	0.7500	5.7500	5.1260	0.9800	1.3800	4.0200	3.7400	6.8900	2.5800	1.3150	1.0630	8.3
2-7/16, 60mm	9 Thru 18TWS200JK	2.6800	2.9500	0.7500	5.7500	5.1260	1.2600	1.3800	4.0200	4.0200	7.8000	2.8200	1.5630	1.0630	8.8

Part Numbers are specified by "WSTU250URW" and Bore Size. Example: WSTU250 x 3/4.

- § Take-Up Units with narrower slots are shown on page N-18.
- 9For Load Ratings, see page N-3.

† DIMENSIONS SHOWN ARE FOR REFERENCE ONLY.

DOWNLOAD AVAILABLE CAD MODELS AT: WWW.HUBCITYINC.COM

Certified prints are available upon request

EMAIL: hubsales@regalbeloit.com • www.hubcityinc.com



Hub City DuraLine® Bearing Units

Bearing Inserts

Series B220R, B250R

B220R Bearing Inserts

- Spherical outside diameter
- Relube type. Prelubricated at factory
- Molded glass fiber reinforced polyamide retainer
- Nitrile rubber seals with steel trash guard
- Eccentric locking collar

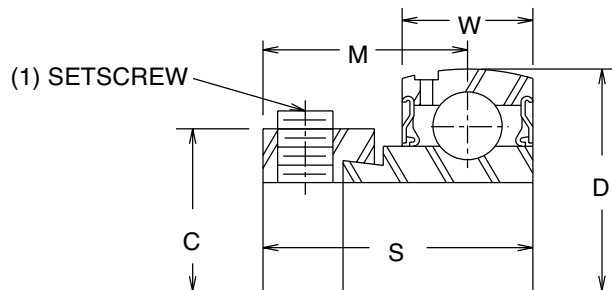

NOTE: BEARINGS WITH ECCENTRIC LOCKING COLLARS ARE NOT RECOMMENDED FOR USE IN REVERSING APPLICATIONS.

SHAFT SIZE	DIMENSIONS						WT. LBS.
	C	D	M	S	W	SETSCREW	
1/2, 5/8	1.1020	1.5748	0.8890	1.1260	0.4720	1/4 - 28 UNF	0.2
3/4	1.2990	1.8504	0.9450	1.2200	0.5510	1/4 - 28 UNF	0.3
7/8, 1	1.4760	2.0472	0.9250	1.2200	0.5910	1/4 - 28 UNF	0.4
1-1/8, 1-3/16, 1-1/4S	1.7320	2.4409	1.0910	1.4060	0.6290	1/4 - 28 UNF	0.6
1-1/4, 1-3/8, 1-7/16	2.1650	2.8346	1.1970	1.5310	0.6690	5/16 - 24 UNF	1.0
1-1/2	2.2830	3.1496	1.3660	1.7200	0.7090	5/16 - 24 UNF	1.3
1-5/8, 1-3/4, 1-11/16	2.4800	3.3465	1.3460	1.7200	0.7480	5/16 - 24 UNF	1.6
1-7/8, 1-15/16, 2S	2.7170	3.5433	1.3270	1.7200	0.7870	3/8 - 24 UNF	1.7
2, 2-3/16	2.9920	3.9370	1.4920	1.9060	0.8270	3/8 - 24 UNF	2.4
2-1/4, 2-7/16	3.3110	4.3307	1.5040	1.9370	0.8660	3/8 - 24 UNF	3.0

Part Numbers are specified by "B220R" and Bore Size. Example B220R x 1-1/4.

Used in PB220, PB221 Pillow Blocks; FB220, FB230 Flange Blocks; and TU220, WSTU220 Take-Up Units.

B250R Bearing Inserts

- Spherical outside diameter
- Relube type. Prelubricated at factory
- Molded glass fiber reinforced polyamide retainer
- Nitrile rubber seals with steel trash guard
- Setscrew Locking

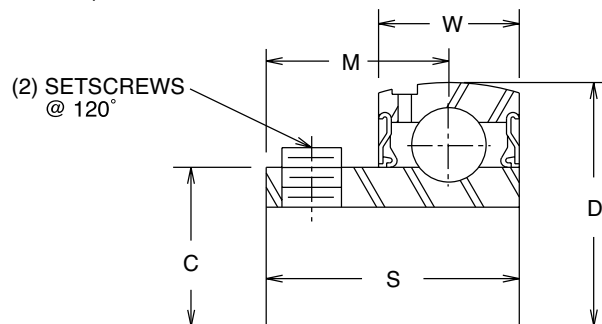

SHAFT SIZE	DIMENSIONS						WT. LBS.
	C	D	M	S	W	SETSCREW	
1/2, 5/8	0.9210	1.5748	0.6290	0.8660	0.4720	1/4 - 28 UNF	0.2
3/4	1.1420	1.8504	0.7090	0.9840	0.5510	1/4 - 28 UNF	0.3
7/8, 1	1.3390	2.0472	0.7680	1.0630	0.5910	1/4 - 28 UNF	0.4
1-1/8, 1-3/16, 1-1/4S	1.5870	2.4409	0.8660	1.1810	0.6290	1/4 - 28 UNF	0.6
1-1/4, 1-3/8, 1-7/16	1.8890	2.8346	0.9250	1.2590	0.6690	5/16 - 24 UNF	1.0
1-1/2	2.0870	3.1496	0.9840	1.3390	0.7090	5/16 - 24 UNF	1.3
1-5/8, 1-3/4, 1-11/16	2.2520	3.3465	1.2200	1.6220	0.7480	5/16 - 24 UNF	1.6
1-7/8, 1-15/16, 2S	2.4330	3.5433	1.2830	1.7130	0.7870	3/8 - 24 UNF	1.7
2, 2-3/16	2.7170	3.9370	1.3190	1.7830	0.8270	3/8 - 24 UNF	2.4
2-1/4, 2-7/16	2.9490	4.3307	1.5280	2.1140	0.8660	3/8 - 24 UNF	3.0

Part Numbers are specified by "B250R" and Bore Size. Example B250R x 1-1/4.

Used in PB100, PB100L, PB150UR, PB150L, PB250, PB251, TPB250 Pillow Blocks; FB100, FB110, FB150, FB160, FB250, FB260 Flange Blocks; and TU250, WSTU250 Take-Up Units.

† DIMENSIONS SHOWN ARE FOR REFERENCE ONLY.

DOWNLOAD AVAILABLE CAD MODELS AT: WWW.HUBCITYINC.COM

Certified prints are available upon request

CALL: (605) 225-0360 • FAX: (605) 225-0567

Hub City DuraLine® Bearing Units

Bearing Inserts

Series B220RW, B250RW

B220RW Bearing Inserts

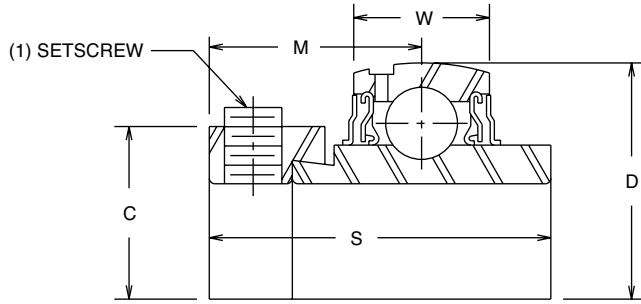

- Spherical outside diameter
- Relube type. Prelubricated at factory
- Molded glass fiber reinforced polyamide retainer
- Nitrile rubber seals with steel trash guard
- Metal flingers
- Eccentric locking collar
- Wide inner race

SHAFT SIZE	DIMENSIONS						WT. LBS.
	C	D	M	S	W	SETSCREW	
3/4	1.2990	1.8504	1.0490	1.7200	0.6290	1/4 - 28 UNF	0.3
7/8, 1	1.4760	2.0472	1.0610	1.7480	0.6690	1/4 - 28 UNF	0.4
1-1/8, 1-3/16, 1-1/4S	1.7320	2.4409	1.1870	1.9060	0.7480	5/16 - 24 UNF	0.6
1-1/4, 1-3/8, 1-7/16	2.1650	2.8346	1.2740	2.0160	0.7870	5/16 - 24 UNF	1.0
1-1/2	2.2830	3.1496	1.3760	2.2200	0.8270	5/16 - 24 UNF	1.3
1-5/8, 1-3/4, 1-11/16	2.4800	3.3465	1.3760	2.2200	0.8660	5/16 - 24 UNF	1.6
1-7/8, 1-15/16, 2S	2.7170	3.5433	1.5000	2.4690	0.9060	5/16 - 24 UNF	1.7
2, 2-3/16	2.9920	3.9370	1.7170	2.8110	0.9840	3/8 - 24 UNF	2.4
2-1/4, 2-7/16	3.3110	4.3307	1.8440	3.0630	1.0630	3/8 - 24 UNF	3.0

Part Numbers are specified by "B220RW" and Bore Size. Example B220RW x 1-1/4.

B250RW Bearing Inserts

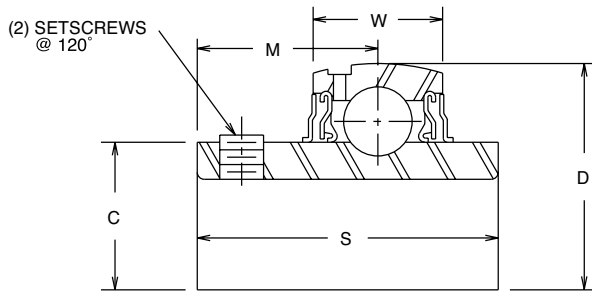

- Spherical outside diameter
- Relube type. Prelubricated at factory
- Molded glass fiber reinforced polyamide retainer
- Nitrile rubber seals with steel trash guard
- Metal flingers
- Setscrew locking
- Wide inner race

SHAFT SIZE	DIMENSIONS						WT. LBS.
	C	D	M	S	W	SETSCREW	
3/4, 20mm	1.1420	1.8504	0.7200	1.2200	0.6290	1/4 - 28 UNF	0.3
7/8, 1, 25mm	1.3390	2.0472	0.7760	1.3390	0.6690	1/4 - 28 UNF	0.4
1-1/8, 1-3/16, 1-1/4S, 30mm	1.5910	2.4409	0.8740	1.5000	0.7480	1/4 - 28 UNF	0.6
1-1/4, 1-3/8, 1-7/16, 35mm	1.8660	2.8346	1.0000	1.6890	0.7870	5/16 - 24 UNF	1.0
1-1/2, 40mm	2.0750	3.1496	1.1890	1.9370	0.8270	5/16 - 24 UNF	1.3
1-5/8, 1-3/4, 1-11/16, 45mm	2.2480	3.3465	1.1890	1.9370	0.8660	5/16 - 24 UNF	1.6
1-7/8, 1-15/16, 2S, 50mm	2.4650	3.5433	1.2830	2.0310	0.9060	3/8 - 24 UNF	1.7
2, 2-3/16, 55mm	2.7760	3.9370	1.3150	2.1890	0.9840	3/8 - 24 UNF	2.4
2-1/4, 2-7/16, 60mm	3.0590	4.3307	1.5630	2.5630	1.0630	3/8 - 24 UNF	3.0

Part Numbers are specified by "B250RW" and Bore Size. Example B250RW x 1-1/4.

DOWNLOAD AVAILABLE CAD MODELS AT: WWW.HUBCITYINC.COM
Certified prints are available upon request

† DIMENSIONS SHOWN ARE FOR REFERENCE ONLY.

EMAIL: hubsales@regalbeloit.com • www.hubcityinc.com



Hub City DuraLine® Bearing Units

Medium Duty

Pillow Block - PB350DRW

Features

- Ductile Iron Housing
- Self-aligning replaceable bearing
- Pre-lubricated with lithium grease
- Steel retainers
- Anti-rotation pins
- Nitrile rubber seals with steel trash guards
- Precision bored housings
- Higher strength and greater impact resistance than gray iron for high shock loads



300 SERIES PILLOW BLOCK

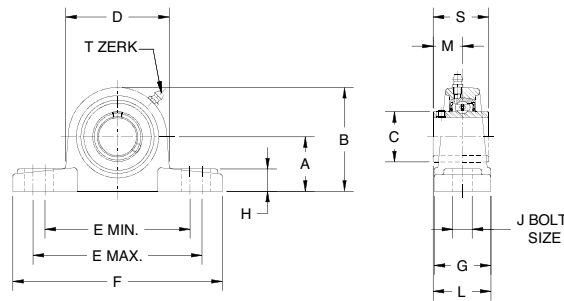

300 SERIES – PILLOW BLOCKS AND FLANGE BLOCKS – CAST IRON – SETSCREW LOCK														
PB350UR														
SHAFT SIZE	A	B	C	D	E MIN.	E MAX.	F	G	H	J	L	M	S	WT. LBS.
1	1.7500	3.3500	1.5910	3.3800	4.2800	5.0900	6.2500	2.0000	0.7100	0.6700	1.8700	0.8740	1.5000	3.3
1-3/16, 1-1/4	1.8750	3.7000	1.8660	3.8100	4.6000	5.4000	6.8800	2.2500	0.7900	0.6700	2.1200	1.0000	1.9370	4.0
1-3/8, 1-7/16	2.1250	4.1300	2.0750	4.2200	5.0700	6.2700	8.0000	2.2500	0.8700	0.6700	2.3100	1.1890	1.9370	4.9
1-1/2	2.3120	4.4500	2.2480	4.4100	5.5900	6.7000	8.7500	2.6300	1.0200	0.7870	2.5000	1.1890	1.9370	5.6
1-5/8, 1-3/4, 1-11/16	2.3120	4.5600	2.4650	4.6600	5.5500	6.7400	8.7500	2.6300	1.0200	0.7870	2.5900	1.2830	2.0310	6.7
1-15/16, 2	2.5000	4.9600	2.7760	5.1300	6.0200	7.4400	9.5000	2.8800	1.0600	0.7870	2.7500	1.3150	2.1890	8.5
2-3/16, 2-1/4	2.7500	5.4700	3.0590	5.4400	6.6600	7.8300	10.2500	3.1200	1.1800	0.9840	3.1200	1.5630	2.5630	11.3
2-7/16, 2-1/2	3.0000	6.0600	3.4250	6.0900	7.2100	8.7700	11.2500	3.2500	1.2600	0.9840	3.3800	1.7480	2.9370	15.2
2-11/16	3.5000	6.7700	3.5980	6.5600	7.9600	10.0700	13.0000	3.5000	1.3800	1.0630	3.5000	1.7520	3.0630	17.9
2-15/16, 3	3.5000	6.9700	3.8780	6.9700	7.9600	10.0700	13.0000	3.5000	1.3800	1.0630	3.6900	1.9410	3.2520	19.1
3-7/16, 3-1/2	4.0000	7.9500	4.4490	7.5600	9.7700	12.5100	15.0000	4.0000	1.6500	1.0630	4.2200	2.2160	3.7800	28.4

Flange Block - FB350DRW

- Ductile Iron Housing
- Self-aligning replaceable bearing
- Pre-lubricated with lithium grease
- Steel retainers
- Anti-rotation pins
- Nitrile rubber seals with steel trash guards
- Precision bored housings
- Higher strength and greater impact resistance than gray iron for high shock loads

300 SERIES FLANGE BLOCK

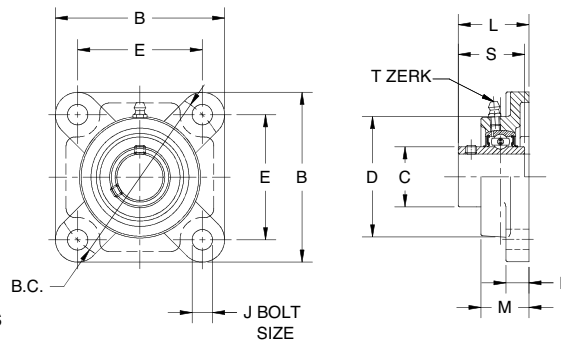

FB350DRW											
SHAFT SIZE	B	B.C.	C	D	E	H	J	L	M	S	WT. LBS.
1	4.2500	4.5960	1.5910	3.1900	3.2500	0.5100	0.4720	1.5830	1.1800	1.5000	3.0
1-3/16, 1-1/4	4.6100	5.1250	1.8660	3.6200	3.6250	0.5600	0.6300	1.7480	1.3400	1.9370	4.2
1-3/8, 1-7/16	5.1200	5.6560	2.0750	4.0900	4.0000	0.5600	0.6300	2.0160	1.5000	1.9370	5.4
1-1/2	5.3900	5.8340	2.2480	4.2500	4.1250	0.5600	0.7480	2.0550	1.5700	1.9370	5.8
1-5/8, 1-3/4, 1-11/16	5.6300	6.1870	2.4650	4.4500	4.3750	0.5600	0.7480	2.1890	1.5700	2.0310	7.0
1-15/16, 2	6.3800	7.2500	2.7760	4.9200	5.1250	0.7900	0.7480	2.3390	1.7300	2.1890	9.2
2-3/16, 2-1/4	6.8900	7.9540	3.0590	5.3100	5.6250	0.7900	0.7480	2.7050	1.9300	2.5630	12.1
2-7/16, 2-1/2	7.3600	8.3080	3.4250	6.1000	5.8750	0.8300	0.7480	3.0870	2.3200	2.9370	15.4
2-11/16	7.7500	8.4850	3.5980	6.3800	6.0000	0.9400	0.9060	3.2090	2.3600	3.0630	18.3
2-15/16, 3	7.7500	8.4850	3.8780	6.7700	6.0000	0.9400	0.9060	3.5160	2.6800	3.2520	19.0
3-7/16, 3-1/2	8.4200	9.5460	4.4490	7.6800	6.7500	0.9400	0.9060	3.7910	2.7500	3.7800	22.2

DuraLine Replacement Inserts
 For 100 and 200 Series Setscrew Lock Use
 B250R, for 100 and 200 Series Eccentric
 Lock Use B220R, for 300 Series Setscrew
 Lock Use B350R

For Load Ratings, See Page N-3

Dimensions shown are for reference only.
 To order, specify type and bore size. Example:
 PB350UR x 1-7/16

DOWNLOAD AVAILABLE CAD MODELS AT: WWW.HUBCITYINC.COM

Certified prints are available upon request

CALL: (605) 225-0360 • FAX: (605) 225-0567

Hub City DuraLine® Bearing Units

Cast Iron Flange Cartridge

Series FC350URW

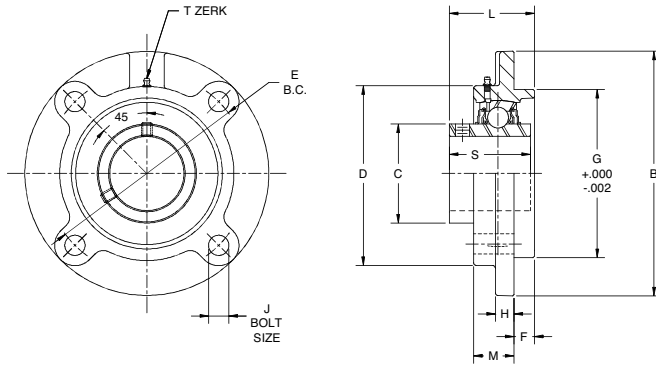

- Relube type. Prelubricated at factory
- Setscrew locking
- Self-aligning replacement bearing
- Nitrile rubber seals with steel trash guard
- Precision bored Cast Iron Housing
- Wide inner ring

SHAFT SIZE	DIMENSIONS											WT. LBS.
	B	C	D	E	F	G	H	J	L	M	S	
1	4.3700	1.5910	3.2500	3.6220	0.2500	3.0000	0.3700	0.3740	1.5200	0.9400	1.2680	3.3
1-3/16, 1-1/4	5.0000	1.8660	3.6200	4.1340	0.3700	3.3740	0.3700	0.4720	1.6800	0.8700	1.3150	3.3
1-3/8, 1-7/16	5.2800	2.0750	3.8800	4.3700	0.4400	3.6220	0.4300	0.4720	1.9800	0.8700	1.5430	3.9
1-1/2	6.1000	2.2480	4.2500	5.1180	0.4300	4.2520	0.4700	0.5510	1.9800	1.0200	1.4050	4.1
1-5/8, 1-3/4, 1-11/16	6.1000	2.4650	4.5000	5.1180	0.4700	4.2520	0.4300	0.5510	2.0700	0.9800	1.5980	5.5
1-15/16, 2	6.3800	2.7760	4.8800	5.3940	0.6300	4.5000	0.5100	0.5510	2.1400	0.9800	1.5900	6.1
2-3/16, 2-1/4	7.0900	3.0590	5.3800	5.9840	0.8700	5.0000	0.6300	0.6300	2.5900	1.0200	1.7200	8.9
2-7/16, 2-1/2	7.6400	3.4250	6.0000	6.4960	0.7800	5.5000	0.5600	0.6300	2.9600	1.3000	2.1810	11.3
2-11/16	8.7400	3.5980	6.3800	7.5000	0.7800	6.3780	0.5600	0.7480	3.0800	1.4200	2.3030	15.4
2-15/16, 3	8.7400	3.8780	6.6200	7.5000	0.8700	6.3780	0.6300	0.7480	3.2800	1.3800	2.4130	15.2
3-7/16, 3-1/2	10.2400	4.4490	7.5000	8.6220	1.0000	7.3740	0.7500	0.9060	3.6100	1.4200	2.6100	22.5

Part Numbers are specified by "FC350" and Bore Size. Example: FC350 x 1-1/2.
For Load Ratings, see page N-3. For Comparison Charts, see page M-40.

For replacement inserts use B350RW Bearing Inserts

Hub City DuraLine® Bearing Units

Medium Duty Take-Up Units

Series TU350URW

- Relube type. Prelubricated at factory
- Setscrew locking
- Self-aligning replacement bearing
- Nitrile rubber seals with steel trash guard
- Precision bored Cast Iron housing

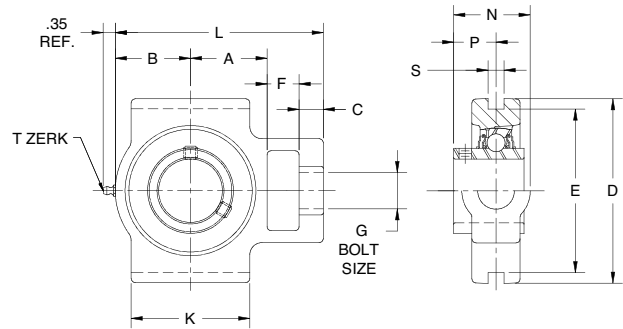

SHAFT SIZE	USE WITH FRAME NO. ★	DIMENSIONS													WT.	
		A	B	C	D	E	F	G	J	K	L	N	P	S§	LBS.	
1	3 Thru 12T200DE	1.6100	1.5800	0.5100	4.0200	3.5040	0.6300	0.8700	2.1300	2.3600	4.6800	1.6800	0.8740	0.3110	3.0	
1-3/16, 1-1/4	3 Thru 12T200DE	1.6900	1.7000	0.5100	4.0200	3.5040	0.7500	0.8700	2.1300	2.6400	5.0000	1.8100	1.0000	0.3110	3.5	
1-3/8, 1-7/16	3 Thru 18T200FH	1.8900	1.8500	0.6300	4.4900	4.0000	0.7500	1.1400	2.6400	2.9500	5.4700	2.1000	1.1890	0.3110	4.0	
1-1/2	3 Thru 18T200FH	2.0500	2.0000	0.6300	4.4900	4.0000	0.7500	1.1400	2.6400	3.1100	5.7800	2.1000	1.1890	0.3110	4.8	
1-5/8, 1-3/4, 1-11/16	3 Thru 18T200FH	2.2000	2.1300	0.6300	4.4900	4.0000	0.7500	1.1400	2.6400	3.3100	6.0600	2.1900	1.2830	0.3110	6.8	
1-15/16, 2	9 Thru 18T200JK	2.3800	2.3300	0.7500	5.7500	5.1260	1.0000	1.3800	3.2700	3.7000	6.8100	2.3800	1.3150	0.3110	9.6	
2-3/16, 2-1/4	9 Thru 18T200JK	2.3800	2.8700	0.7500	5.7500	5.1260	1.0000	1.3800	3.2700	4.0600	7.6700	2.6300	1.5630	0.3110	12.0	

Part Numbers are specified by "TU350URW" and Bore Size. Example: TU350URW x 2-1/4.
For replacement inserts use B350RW Bearing Inserts.

★ Take-Up Frames shown on page M-33.
For Load Ratings, see page N-3.

† DIMENSIONS SHOWN ARE FOR REFERENCE ONLY.

Medium Duty Wide Slot Take-Up Units

Series WSTU350URW

- Relube type. Prelubricated at factory
- Setscrew locking
- Self-aligning replacement bearing
- Nitrile rubber seals with steel trash guard
- Precision bored Cast Iron housing

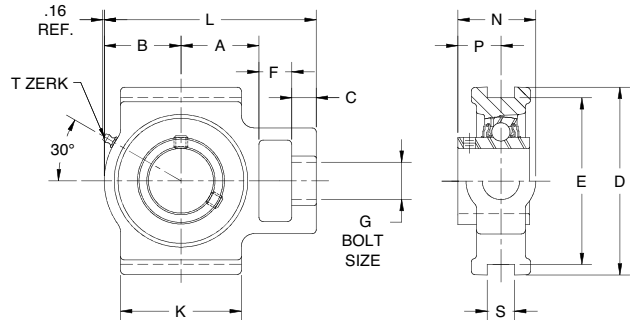

SHAFT SIZE	USE WITH FRAME NO. ★	DIMENSIONS													WT.	
		A	B	C	D	E	F	G	J	K	L	N	P	S§	LBS.	
1	3 Thru 12TWS200DE	1.7300	1.6900	0.4000	4.0200	3.5040	0.6300	0.8700	2.2000	2.2500	4.6100	1.6100	0.8740	0.5310	3.0	
1-3/16, 1-1/4	3 Thru 12TWS200DE	1.9300	2.0100	0.5100	4.0200	3.5040	0.6300	0.8700	2.5200	2.5200	5.2400	1.7300	1.0000	0.5310	3.5	
1-3/8, 1-7/16	3 Thru 18TWS200FH	2.1200	2.1700	0.6300	4.4900	4.0000	0.7500	1.1400	3.2700	3.2700	5.8300	2.1600	1.1890	0.6890	4.0	
1-1/2	3 Thru 18TWS200FH	2.0500	2.2400	0.6300	4.4900	4.0000	0.7500	1.1400	3.2700	3.2700	5.8300	2.1600	1.1890	0.6890	4.8	
1-5/8, 1-3/4, 1-11/16	3 Thru 18TWS200FH	2.1600	2.3300	0.6300	4.4900	4.0000	0.7500	1.1400	3.2700	3.3800	6.0300	2.2500	1.2830	0.6890	6.8	
1-15/16, 2	9 Thru 18TWS200JK	2.4400	2.5600	0.7500	5.7500	5.1260	0.9800	1.3800	4.0200	3.7400	6.8900	2.5800	1.3150	1.0630	9.6	
2-3/16, 2-1/4	9 Thru 18TWS200JK	2.6800	2.9500	0.7500	5.7500	5.1260	1.2600	1.3800	4.0200	4.0200	7.8000	2.8200	1.5630	1.0630	12.0	
2-7/16, 2-1/2	----	3.3100	3.4200	0.8300	6.5700	5.9450	1.2600	1.6200	4.3700	4.7600	8.9800	2.9400	1.5630	1.0630	16.0	

Part Numbers are specified by "WSTU350URW" and Bore Size. Example: WSTU350URW x 2-1/4.
For replacement inserts use B350RW Bearing Inserts, see page M-35.

★ Take-Up Frames shown on page M-34.
For Load Ratings, see page N-3.

† DIMENSIONS SHOWN ARE FOR REFERENCE ONLY.

DOWNLOAD AVAILABLE CAD MODELS AT: WWW.HUBCITYINC.COM

Certified prints are available upon request

CALL: (605) 225-0360 • FAX: (605) 225-0567

Hub City DuraLine® Bearing Units Bearing Inserts

Series B350RW

- Spherical outside diameter
- Relube type. Prelubricated at factory
- Molded glass fiber reinforced polyamide retainer
- Nitrile rubber seals with steel flingers
- Setscrew locking
- Medium duty
- Wide inner ring

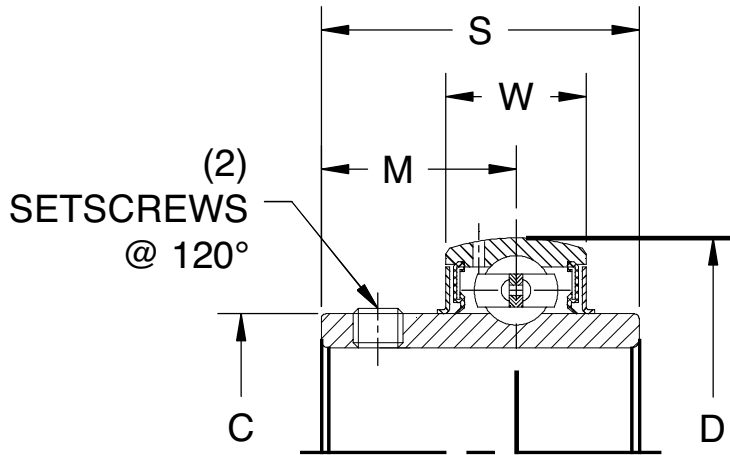

SHAFT SIZE	DIMENSIONS						WT. LBS.
	C	D	M	S	W	SETSCREW	
1	1.5870	2.4409	0.8740	1.5000	0.7480	1/4 - 28 UNF	1.0
1-3/16, 1-1/4	1.8900	2.8346	1.0000	1.6890	0.7870	1/4 - 28 UNF	1.3
1-3/8, 1-7/16	2.0870	3.1496	1.1890	1.9370	0.8270	5/16 - 24 UNF	1.6
1-1/2	2.2520	3.3465	1.1890	1.9370	0.8660	5/16 - 24 UNF	1.9
1-5/8, 1-3/4, 1-11/16	2.4330	3.5433	1.2830	2.0310	0.9060	5/16 - 24 UNF	2.2
1-15/16, 2	2.7170	3.9370	1.3150	2.1890	0.9840	3/8 - 24 UNF	2.6
2-3/16, 2-1/4	2.9490	4.3307	1.5630	2.5630	1.0630	3/8 - 24 UNF	3.1
2-7/16, 2-1/2	3.4060	4.9213	1.7480	2.9370	1.1410	7/16 - 20 UNF	5.1
2-11/16	3.6020	5.1181	1.7520	3.0630	1.1810	7/16 - 20 UNF	5.6
2-15/16, 3	3.8580	5.5118	1.9410	3.2520	1.2600	7/16 - 20 UNF	6.4
3-7/16, 3-1/2	4.3700	6.2992	2.2160	3.7800	1.4570	7/16 - 20 UNF	8.5

Part Numbers are specified by "B350" and Bore Size. Example: B350RW x 1-1/2.

Hub City DuraLine® Bearing Units

Quick Reference Competitor Product Interchange Guide

TO USE THIS GUIDE: 1. LOCATE THE COMPETITOR'S PREFIX IN THE APPROPRIATE COLUMN. FOLLOW THE LINE LEFT TO READ THE DURALINE PREFIX LOCATED ON THE SAME LINE. 2. LOCATE THE COMPETITORS SUFFIX IN THE APPROPRIATE COLUMN. FOLLOW THE LINE LEFT TO READ THE CORRECT DURALINE SIZE. 3. COMBINE DURALINE PREFIX AND SIZE FOR PROPER ORDERING INFORMATION.

Normal Duty Pillow Blocks

	DuraLine	AMI	FYH	IPTCI	PEER	SST
PREFIX	PB220UR	KHLP	EASL	SAPL	FHLP	SAAK
	PB220DRW		NAPK	NAPL	HCLP	HCAK
	PB221UR	KHP	EAP	SAP	FHP	SAP
	PB221DRW	UGP	NAP	NAP	HCP	HCP
	PB250UR		EBSL	SBPL	FHSLP	SBAK
	PB250DRW	UCLP	SL	UCPL	UCLP	UCAK
	PB251UR		UCP	SBP	FHSP	SBP
	PB251DRW	UCP	UCP	UCP	UCP	UCP
	TPB250UR			SBPA		
	TPB250DRW	UCTB	UCPAN	UCPA	UCPA	UCPA
SIZE/SUFFIX	1/2	201-8	201-8	201-8	201-8	201-8
	5/8	202-10	202-10	202-10	202-10	202-10
	3/4	204-12	204-12	204-12	204-12	204-12
	7/8	205-14	205-14	205-14	205-14	205-14
	1	205-16	205-16	205-16	205-16	205-16
	1-1/8	206-18	206-18	206-18	206-18	206-18
	1-3/16	206-19	206-19	206-19	206-19	206-19
	1-1/4S	206-20	206-20	206-20	206-20	206-20
	1-1/4	207-20	207-20	207-20	207-20	207-20
	1-3/8	207-22	207-22	207-22	207-22	207-22
	1-7/16	207-23	207-23	207-23	207-23	207-23
	1-1/2	208-24	208-24	208-24	208-24	208-24
	1-5/8	209-26	209-26	209-26	209-26	209-26
	1-11/16	209-27	209-27	209-27	209-27	209-27
	1-3/4	209-28	209-28	209-28	209-28	209-28
	1-7/8	210-30	210-30	210-30	210-30	210-30
	1-15/16	210-31	210-31	210-31	210-31	210-31
	2S	210-32	210-32	210-32	210-32	210-32
	2	211-32	211-32	211-32	211-32	211-32
	2-3/16	211-35	211-35	211-35	211-35	211-35
2-7/16	212-39	212-39	212-39	212-39	212-39	
2-15/16	215-47	215-47	215-47	215-47	215-47	

Normal Duty Flange Blocks & Flange Brackets

	DuraLine	AMI	FYH	IPTCI	PEER	SST
PREFIX	FB220UR	KHF	EAF	SAF	FHF	SAF-S
	FB220DRW		NANF	SAF	HCFS	HCFS
	FB230UR	KHFT	EAF	SAFL	FHFT	SAFT
	FB230DRW	UGJFT	NANFL	NANFL	HCFTS	HCFT
	FB250UR		EBF	SBF	FHSF	SBF-S
	FB250DRW	UCF		UCF	UCF	UCF
	FB260UR		EBFL	SBFL	FHFST	SBFT
	FB260DRW	UCFT	UCFL	UCFL	UCFT	UCFT
	FR250URW	UCFB	UCFB	UCFB	UCFB	
	SIZE/SUFFIX	1/2	201-8	201-8	201-8	201-8
5/8		202-10	202-10	202-10	202-10	202-10
3/4		204-12	204-12	204-12	204-12	204-12
7/8		205-14	205-14	205-14	205-14	205-14
1		205-16	205-16	205-16	205-16	205-16
1-1/8		206-18	206-18	206-18	206-18	206-18
1-3/16		206-19	206-19	206-19	206-19	206-19
1-1/4S		206-20	206-20	206-20	206-20	206-20
1-1/4		207-20	207-20	207-20	207-20	207-20
1-3/8		207-22	207-22	207-22	207-22	207-22
1-7/16		207-23	207-23	207-23	207-23	207-23
1-1/2		208-24	208-24	208-24	208-24	208-24
1-5/8		209-26	209-26	209-26	209-26	209-26
1-11/16		209-27	209-27	209-27	209-27	209-27
1-3/4		209-28	209-28	209-28	209-28	209-28
1-7/8		210-30	210-30	210-30	210-30	210-30
1-15/16		210-31	210-31	210-31	210-31	210-31
2S		210-32	210-32	210-32	210-32	210-32
2		211-32	211-32	211-32	211-32	211-32
2-3/16		211-35	211-35	211-35	211-35	211-35
2-7/16	212-39	212-39	212-39	212-39	212-39	
2-15/16	215-47	215-47	215-47	215-47	215-47	

Light Duty Flange Blocks

	DuraLine	AMI	FYH	IPTCI	PEER	SST
PREFIX	FB100UR	BTM		SBRFB	FHFS3X	SBFCT
	FB150UR			FHFS3X-G	SBFCT-G	
	FB110UR			SBFL- _{-H4}	FHSFX	SBFTD
	FB160UR			SBFL- _{-GH4}	FHSFX-G	SBFTD-G
SIZE/SUFFIX	1/2	201-8	201-8	201-8	201-8	201-8
	5/8	202-10	202-10	202-10	202-10	202-10
	3/4	204-12	204-12	204-12	204-12	204-12
	7/8	205-14	205-14	205-14	205-14	205-14
	1	205-16	205-16	205-16	205-16	205-16
	1-1/8	206-18	206-18	206-18	206-18	206-18
	1-3/16	206-19	206-19	206-19	206-19	206-19
	1-1/4S	206-20	206-20	206-20	206-20	206-20
	1-1/4	207-20	207-20	207-20	207-20	207-20
	1-3/8	207-22	207-22	207-22	207-22	207-22
	1-7/16	207-23	207-23	207-23	207-23	207-23

Medium Duty Pillow Blocks & Flange Blocks

	DuraLine	AMI	FYH	IPTCI	PEER	SST
PREFIX	PB350UR	UCP	UCP	UCP	UCP	UCP
	FB350UR	UCF	UCF	UCF	UCF	UCF
SIZE/SUFFIX	1	X05-16	X05-16	X05-16	X05-16	X05-16
	1-7/16	X07-23	X07-23	X07-23	X07-23	X07-23
	1-1/2	X08-24	X08-24	X08-24	X08-24	X08-24
	1-3/4	X09-28	X09-28	X09-28	X09-28	X09-28
	1-15/16	X10-31	X10-31	X10-31	X10-31	X10-31
	2	X11-32	X11-32	X11-32	X11-32	X11-32
	2-3/16	X11-35	X11-35	X11-35	X11-35	X11-35
	2-7/16	X12-39	X12-39	X12-39	X12-39	X12-39
	2-1/2	X13-40	X13-40	X13-40	X13-40	X13-40
	2-11/16	X14-43	X14-43	X14-43	X14-43	X14-43
	2-15/16	X15-47	X15-47	X15-47	X15-47	X15-47
	3	X15-48	X15-48	X15-48	X15-48	X15-48
	3-7/16	X17-55	X17-55	X17-55	X17-55	X17-55
	3-1/2	X18-56	X18-56	X18-56	X18-56	X18-56

NOTE: ABOVE GUIDE IS DESIGNED FOR QUICK REFERENCE ONLY. PLEASE REVIEW AND CONFIRM ALL CRITICAL DIMENSIONS BEFORE PLACING YOUR ORDER. NOT ALL CONFIGURATIONS ARE AVAILABLE IN EACH SIZE LISTED. CONFIRM AVAILABILITY IN CATALOG DIMENSIONAL PAGES.

DURALINE NOMENCLATURE GUIDE:

PB: PILLOW BLOCK
 FB: FLANGE BLOCK
 FR: FLANGE CARTRIDGE
 100 SERIES: LIGHT DUTY SETSCREW LOCK
 220: SERIES NORMAL DUTY ECCENTRIC LOCK
 221 SERIES NORMAL DUTY ECCENTRIC LOCK -HIGH BASE
 230 SERIES: NORMAL DUTY ECCENTRIC LOCK -2 BOLT FLANGE

250 SERIES: NORMAL DUTY SETSCREW LOCK
 251 SERIES: NORMAL DUTY SETSCREW LOCK-HIGH BASE
 260 SERIES: NORMAL DUTY SETSCREW LOCK - 2 BOLT FLANGE
 350 SERIES: MEDIUM DUTY SETSCREW LOCK
 UR: CAST IRON DURALINE HOUSING (100 SERIES IS DUCTILE)
 DR: DUCTILE IRON DURALINE HOUSING
 W: WIDE INNER RACE

DOWNLOAD AVAILABLE CAD MODELS AT: WWW.HUBCITYINC.COM

Certified prints are available upon request

CALL: (605) 225-0360 • FAX: (605) 225-0567

Hub City CleanLine™ Bearing Units

Solutions for Pharmaceutical, Meat, Poultry and Produce Processing & Washdown Applications.

CleanLine™ Features	O-2
CleanLine UltraPlus™ Stainless Steel Mounted Bearings	O-3 to O-6
CleanLine Plus™ Thermoplastic Composite Mounted Bearings	O-7 to O-8
Stainless Steel Bearing Inserts	O-9
Thermoplastic Composite Housing Load Ratings	O-10
Mounted Bearing Accessories	O-11 to O-13

Over 50 NEW items in this section!

Hub City CleanLine™ Bearing Units

CleanLine UltraPlus™ Stainless Steel Mounted Bearings - Ultimate Solutions

Features:

- 304 Stainless Steel Housing
- 440 Stainless Steel Rings and Balls
- 302 Stainless Steel Flingers and Retainers
- Factory Filled with USDA H1 Lubricant
- Machine Polished to NSF/3-A or Industry Approved Standards
- Bore Sizes Up to 1.9375
- HACCP Compatible



CleanLine Plus™ Thermoplastic Composite Mounted Bearings - Intermediate Solutions

Features:

- Ultradur® Glass Reinforced PBT Thermoplastic Housings
- 440 Stainless Steel Rings and Balls
- 302 Stainless Steel Flingers and Retainers
- Factory Filled with USDA H1 Lubricant
- Smooth Surface for Easy Cleaning
- Bore Sizes Up to 1.5"



DOWNLOAD AVAILABLE CAD MODELS AT: WWW.HUBCITYINC.COM
Certified prints are available upon request
CALL: (605) 225-0360 • FAX: (605) 225-0567

Hub City CleanLine™ Bearing Units

CleanLine UltraPlus™ and Pharmaceutical Stainless Steel Mounted Bearings

Series PB251STW - Pillow Block



Features:

- 440 Stainless Steel Rings and Balls
- 302 Stainless Steel Flingers and Retainers
- Setscrew Lock - Wide Inner Ring
- Factory Filled USDA H1 Lubricant Meets FDA Regulation 178.3570 Requirement for Incidental Contact with Food
- 304 Stainless Steel Setscrews
- Anti Rotation Pin
- 304 Stainless Steel Housing
- No Ribs Undercuts or Protrusions - Easier to Clean
- Stainless Steel Grease Fittings
- Grooved for Composite Dust Caps on One Side,

See Page O-13

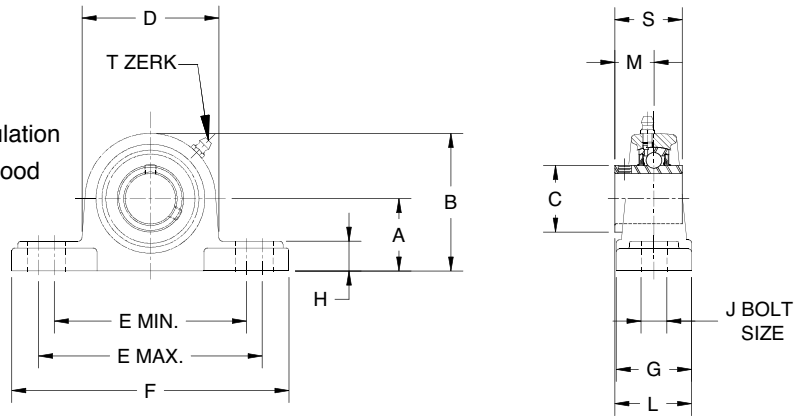

SHAFT SIZE	A	B	C	D	E MIN.	E MAX.	F	G	H	J	L	M	S	WT. LBS.
1/2, 5/8, 3/4	1.3120	2.5600	1.1400	2.5600	3.4600	4.0200	5.0000	1.5000	.5100	.5100	1.4700	.7200	1.2200	1.4
7/8, 1	1.4380	2.8000	1.3400	2.8700	3.8600	4.4100	5.5100	1.5000	.5900	.5100	1.5300	.7790	1.3430	1.7
1-1/8, 1-3/16, 1-1/4s	1.6880	3.3100	1.5900	3.3900	4.5600	4.9600	6.5000	1.8900	.6700	.6700	1.8200	.8740	1.5000	2.9
1-1/4, 1-3/8, 1-7/16	1.8740	3.6600	1.8900	3.7400	4.8000	5.2000	6.5700	1.8900	.7500	.6700	1.8200	1.0000	1.6890	3.5
1-1/2	1.9380	3.8600	2.0600	4.1300	5.2000	5.5900	7.2500	2.1300	.7900	.6700	2.2500	1.1890	1.9370	4.4
1-5/8, 1-11/16, 1-3/4	2.1250	4.1700	2.2600	4.4100	5.5500	5.9400	7.4800	2.1300	.7900	.6700	2.2500	1.1890	1.9370	5.0
1-15/16	2.2500	4.5000	2.4900	4.6900	6.1000	6.4200	8.1100	2.3600	.8700	.7900	2.4600	1.2830	2.0310	5.9

Part Numbers are specified by "PB251STW" and Bore Size. Example: PB251STW x 1.
For replacement inserts use B250TW Bearing Inserts, O-9
T-Zerk: 1/4-28 Taper

For Load Ratings, See page O-10.

Series TPB250STW - Tapped Base Pillow Block

Features: (same as above)

FOR LUBRICATION AND INSTALLATION
INSTRUCTIONS - REFER TO SECTION S

NOTE: PRODUCTS ON THIS PAGE ARE AVAILABLE WITH
TRIPLE LIP SEALS (SEE PAGE O-9)
TO ORDER ADD SUFFIX L3 (EXAMPLE PB251STWX1L3)

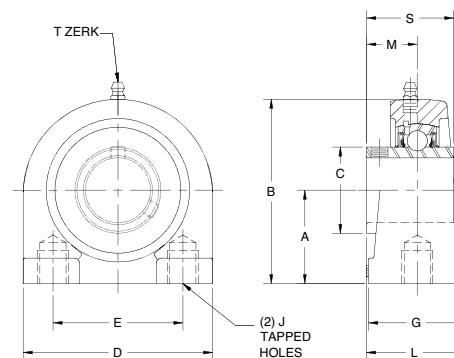

SHAFT SIZE	A	B	C	D	E	G	J - TAPPED HOLES	L	M	S	WT. LBS.
1/2, 5/8, 3/4	1.3120	2.5600	1.1400	2.8700	2.0000	1.5000	3/8-16UNC X .50	1.4700	.7200	1.2060	0.8
7/8, 1	1.4370	2.8000	1.3400	3.0000	2.0000	1.5000	3/8-16UNC X .50	1.5300	.7790	1.3430	0.9
1-1/8, 1-3/16, 1-1/4s	1.6870	3.3800	1.5900	4.0000	3.0000	1.5000	7/16-14UNC X .63	1.6200	.8740	1.5000	1.9
1-1/4, 1-3/8, 1-7/16	1.8750	3.7400	1.8900	4.2500	3.2500	1.8900	1/2-13UNC X .75	1.9500	1.0000	1.6890	2.0
1-1/2	1.9370	3.9400	2.0600	4.6100	3.5000	1.8900	1/2-13UNC X .75	2.1300	1.1890	1.9370	2.8
1-5/8, 1-11/16, 1-3/4	2.1250	4.2500	2.2600	5.0000	3.7500	2.0000	1/2-13UNC X .75	2.1900	1.1890	1.9370	3.3
1-15/16	2.2500	4.6400	2.4900	5.5000	4.0000	2.0000	5/8-11UNC X .79	2.2800	1.2830	2.0310	4.2

Part Numbers are specified by "TPB250STW" and Bore Size. Example: TPB250STW x 3/4.
For replacement inserts use B250TW Bearing Inserts, O-9
T-Zerk: 1/4-28 Taper

For Load Ratings, See page O-10.

DOWNLOAD AVAILABLE CAD MODELS AT: WWW.HUBCITYINC.COM

Certified prints are available upon request

EMAIL: hubsales@regalbeloit.com • www.hubcityinc.com

⚠ DIMENSIONS SHOWN ARE FOR REFERENCE ONLY.



Hub City CleanLine™ Bearing Units

CleanLine UltraPlus™ and Pharmaceutical Stainless Steel Mounted Bearings



Series FB250STW - Four Bolt Flange Blocks

Features:

- 440 Stainless Steel Rings and Balls
- 302 Stainless Steel Flingers and Retainers
- Setscrew Lock - Wide Inner Ring
- Factory Filled USDA H1 Lubricant Meets FDA Regulation 178.3570 Requirement for Incidental Contact with Food
- 304 Stainless Steel Setscrews
- Anti Rotation Pin
- 304 Stainless Steel Housing
- No Ribs - Undercuts or Protrusions Easier to Clean
- Stainless Steel Grease Fittings
- Grooved for Composite Dust Caps on One Side, See Page O-13

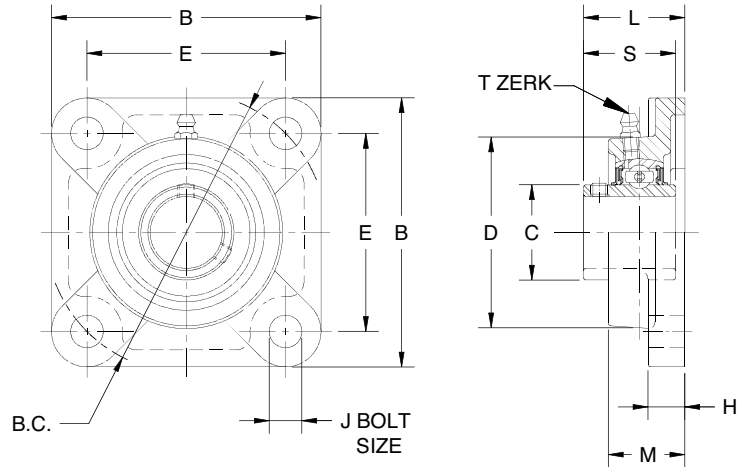

SHAFT SIZE	B	B.C.	C	D	E	H	J	L	M	S	WT. LBS.
1/2, 5/8, 3/4	3.3800	3.5630	1.1400	2.3600	2.5200	.4700	.4720	1.3110	1.0000	1.2200	1.3
7/8, 1	3.7400	3.8980	1.3400	2.8000	2.7560	.5100	.4720	1.4090	1.0600	1.3420	1.8
1-1/8, 1-3/16, 1-1/4s	4.2500	4.6220	1.5900	3.1900	3.2680	.5100	.4720	1.5830	1.2200	1.5000	2.4
1-1/4, 1-3/8, 1-7/16	4.6100	5.1220	1.8900	3.6200	3.6220	.5900	.5510	1.7480	1.3400	1.6890	3.5
1-1/2	5.1200	5.6790	2.0600	4.0900	4.0160	.5900	.6300	2.0160	1.4200	1.9370	4.2
1-5/8, 1-11/16, 1-3/4	5.3900	5.8460	2.2600	4.2500	4.1340	.6300	.6300	2.0550	1.5000	1.9370	5.3
1-15/16	5.6300	6.1800	2.4900	4.4500	4.3700	.6300	.6300	2.1500	1.5700	2.0310	5.7

Part Numbers are specified by "FB250STW" and Bore Size. Example: FB250STW x 3/4.
For replacement inserts use B250TW Bearing Inserts, O-9.
T-Zerk: 1/4-28 Taper

For Load Ratings, See page O-10.

Series FB260STW - Two Bolt Flange Blocks

Features: (same as above)

FOR LUBRICATION AND INSTALLATION INSTRUCTIONS - REFER TO SECTION S

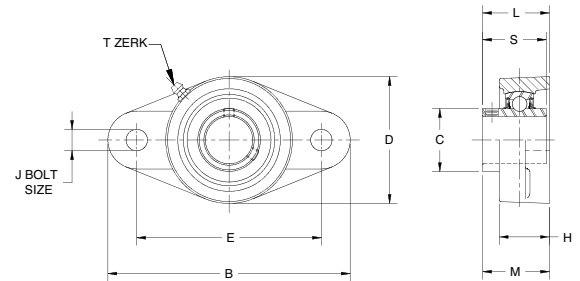

NOTE: PRODUCTS ON THIS PAGE ARE AVAILABLE WITH TRIPLE LIP SEALS (SEE PAGE O-9)
TO ORDER ADD SUFFIX L3 (EXAMPLE PB2515TWX1L3)

SHAFT SIZE	B	C	D	E	H	J	L	M	S	WT. LBS.
1/2, 5/8, 3/4	4.4500	1.1400	2.3600	3.5430	.4300	.4130	1.3110	1.0000	1.2200	1.1
7/8, 1	5.1200	1.3400	2.6800	3.8980	.5100	.4920	1.4090	1.0600	1.3420	1.4
1-1/8, 1-3/16, 1-1/4s	5.8300	1.5900	3.1500	4.6060	.5100	.4920	1.5830	1.2200	1.5000	1.9
1-1/4, 1-3/8, 1-7/16	6.3400	1.8900	3.5400	5.1180	.6300	.5510	1.7480	1.3400	1.6890	2.6
1-1/2	6.8900	2.0600	3.9400	5.6690	.6300	.5510	2.0160	1.4200	1.9370	3.5
1-5/8, 1-11/16, 1-3/4	7.4000	2.2600	4.2500	5.8270	.6300	.6300	2.0550	1.5000	1.9370	4.2
1-15/16	7.6700	2.4900	4.5300	6.1810	.6300	.6300	2.1500	1.5700	2.0310	5.1

Part Numbers are specified by "FB260STW" and Bore Size. Example: FB260STW x 3/4.
For replacement inserts use B250TW Bearing Inserts, O-9.
T-Zerk: 1/4-28 Taper

For Load Ratings, See page O-10.

¶ DIMENSIONS SHOWN ARE FOR REFERENCE ONLY.

DOWNLOAD AVAILABLE CAD MODELS AT: WWW.HUBCITYINC.COM

Certified prints are available upon request

CALL: (605) 225-0360 • FAX: (605) 225-0567

Hub City CleanLine™ Bearing Units

CleanLine UltraPlus™ and Pharmaceutical Stainless Steel Mounted Bearings

Series FR250STW - Three Bolt Flange Bracket

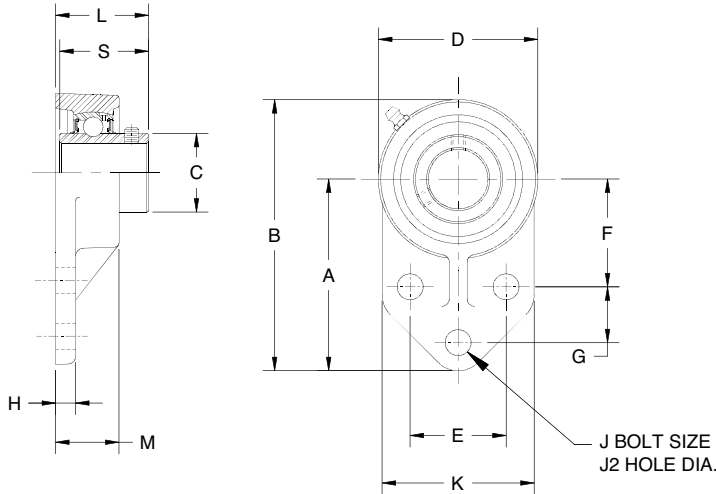
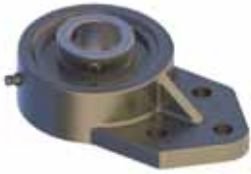

Features:

- 440 Stainless Steel Rings and Balls
- 302 Stainless Steel Flingers and Retainers
- Setscrew Lock - Wide Inner Ring
- Factory Filled USDA H1 Lubricant Meets FDA Regulation 178.3570 Requirement for Incidental Contact with Food
- 304 Stainless Steel Setscrews
- Anti Rotation Pin
- 304 Stainless Steel Housing
- No Ribs - Undercuts or Protrusions Easier to Clean
- Stainless Steel Grease Fittings
- Grooved for Composite Dust Caps on One Side, See Page O-13

SHAFT SIZE	A	B	C	D	E	F	G	H	J	J2	K	L	M	S	WT LBS
1/2, 5/8, 3/4	3.0000	4.2500	1.1400	2.5000	1.5000	1.6880	.8750	.3100	0.3125	.3940	2.3800	1.3500	1.0000	1.2200	1.3
7/8, 1	3.3800	4.7500	1.3400	2.7500	1.6250	1.8120	1.1250	.3800	0.3125	.3940	2.5000	1.4480	1.1400	1.3380	1.8
1-1/8, 1-3/16, 1-1/4s	3.7500	5.3800	1.5900	3.2500	1.8750	2.0630	1.2500	.3800	0.3125	.3940	2.7500	1.6220	1.2600	1.5000	2.4
1-1/4, 1-3/8, 1-7/16	4.2500	6.1200	1.8900	3.7500	2.0000	2.3750	1.2500	.5000	0.4375	.4720	3.2500	1.8270	1.4600	1.6890	3.5
1-1/2	4.5000	6.4400	2.0600	3.9400	2.0000	2.3750	1.6250	.6300	0.3750	.4720	3.0600	2.0160	1.3400	1.9370	4.2
1-5/8, 1-11/16, 1-3/4	4.7500	6.8700	2.2600	4.1800	2.1250	2.5620	1.6880	.7200	0.3750	.4720	3.1300	2.0160	1.3400	1.9370	5.3
1-15/16	5.1800	7.5000	2.4900	4.6500	2.7500	2.9370	1.6250	.5000	0.4375	.5120	4.0000	2.1100	1.5000	2.0310	5.7

Part Numbers are specified by "FR250STW" and Bore Size. Example: FR250STW x 3/4.
For replacement inserts use B250TW Bearing Inserts, O-9.
T-Zerk: 1/4-28 Taper

For Load Ratings, See page O-10.



Series TU250STW - Take Up Unit

Features: (same as above)

FOR LUBRICATION AND INSTALLATION
INSTRUCTIONS - REFER TO SECTION S

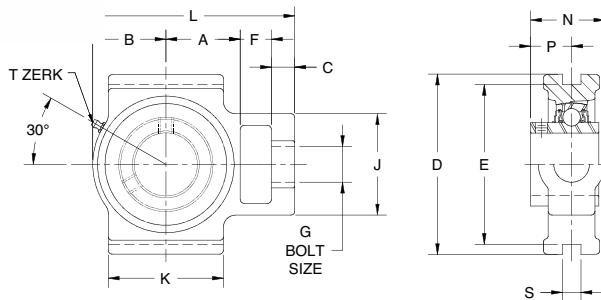

NOTE: PRODUCTS ON THIS PAGE ARE AVAILABLE
WITH TRIPLE LIP SEALS (SEE PAGE O-9)
TO ORDER ADD SUFFIX L3 (EXAMPLE
PB2515TWX1L3)

SHAFT SIZE	A	B	C	D	E	F	G	J	K	L	N	P	S	WT LBS
1/2, 5/8, 3/4	1.3300	1.2200	.2800	3.4400	3.0000	.6300	.7500	1.8500	1.8500	3.4600	1.3500	.7200	.3110	1.8
7/8, 1	1.4100	1.3400	.2800	3.4400	3.0000	.6300	.7500	1.8500	1.8500	3.6600	1.4100	.7790	.3110	2.7
1-1/8, 1-3/16, 1-1/4s	1.7000	1.6100	.3500	3.9400	3.5040	.6300	.8700	2.2400	2.0900	4.2900	1.6000	.8740	.3110	3.6
1-1/4, 1-3/8, 1-7/16	1.8900	1.8500	.3500	3.9400	3.5040	.6300	.8700	2.2400	2.3600	4.7200	1.7300	1.0000	.3110	5.0
1-1/2	2.0400	2.0500	.4700	4.4400	4.4000	.7500	1.1400	3.1500	2.9500	5.3100	1.9500	.9840	.3110	6.2
1-5/8, 1-11/16, 1-3/4	2.0500	2.2000	.5500	4.4400	4.0000	.7500	1.1400	3.1500	3.1100	5.5500	2.1900	1.2200	.3110	7.3
1-15/16	2.2000	2.3200	.5500	4.4400	4.0000	.7500	1.1400	3.2300	3.2300	5.8200	2.2500	1.2830	.3110	8.0

Part Numbers are specified by "TU250STW" and Bore Size. Example: TU250STW x 3/4.
For replacement inserts use B250TW Bearing Inserts, O-9.
T-Zerk: 1/4-28 Taper

For Load Ratings, See page O-10.

DOWNLOAD AVAILABLE CAD MODELS AT: WWW.HUBCITYINC.COM

Certified prints are available upon request

EMAIL: hubsales@regalbeloit.com • www.hubcityinc.com

⚠ DIMENSIONS SHOWN ARE FOR REFERENCE ONLY.



Hub City CleanLine™ Bearing Units

CleanLine UltraPlus™ and Pharmaceutical Stainless Steel Mounted Bearings

Series WSTU250STW - Wide Slot Take Up Unit

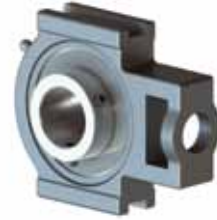

Features:

- 440 Stainless Steel Rings and Balls
- 302 Stainless Steel Flingers and Retainers
- Setscrew Lock - Wide Inner Ring
- Factory Filled USDA H1 Lubricant Meets FDA Regulation 178.3570 Requirement for Incidental Contact with Food
- 304 Stainless Steel Setscrews
- Anti Rotation Pin
- 304 Stainless Steel Housing
- No Ribs - Undercuts or Protrusions Easier to Clean
- Stainless Steel Grease Fittings
- Grooved for Composite Dust Caps on One Side,
See Page O-13

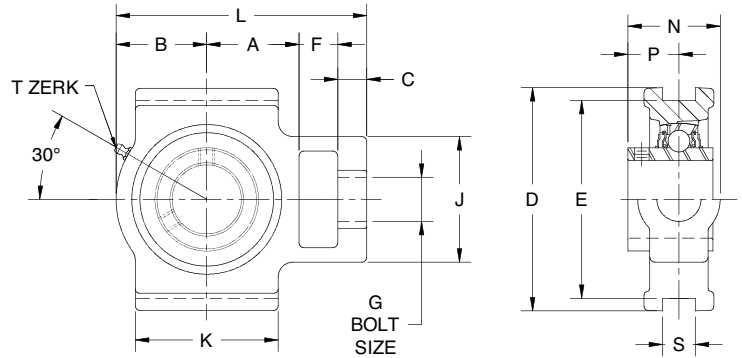

SHAFT SIZE	A	B	C	D	E	F	G	J	K	L	N	P	S	WT LBS
1/2, 5/8, 3/4	1.3300	1.2200	.2800	3.4400	3.0000	.6300	.7500	1.8500	1.8500	3.4600	1.3500	.7200	.5310	1.8
7/8, 1	1.4100	1.3400	.2800	3.4400	3.0000	.6300	.7500	1.8500	1.8500	3.6600	1.4100	.7790	.5310	2.7
1-1/8, 1-3/16, 1-1/4s	1.7000	1.6100	.3500	3.9400	3.5040	.6300	.8700	2.2400	2.0900	4.2900	1.6000	.8740	.5310	3.6
1-1/4, 1-3/8, 1-7/16	1.8900	1.8500	.3500	3.9400	3.5040	.6300	.8700	2.2400	2.3600	4.7200	1.7300	1.0000	.5310	5.0
1-1/2	2.0400	2.0500	.4700	4.4400	4.0000	.7500	1.1400	3.1500	2.9500	5.3100	1.9500	.9840	.6890	6.2
1-5/8, 1-11/16, 1-3/4	2.0500	2.2000	.5500	4.4400	4.0000	.7500	1.1400	3.1500	3.1100	5.5500	2.1900	1.2200	.6890	7.3
1-15/16	2.2000	2.3200	.5500	4.4400	4.0000	.7500	1.1400	3.2300	3.2300	5.8200	2.2500	1.2830	.6890	8.0

Part Numbers are specified by "WSTU250STW" and Bore Size. Example: WSTU250STW x 3/4.
For replacement inserts use B250TW Bearing Inserts, O-9.
T-Zerk: 1/4-28 Taper

For Load Ratings, See page O-10.

FOR LUBRICATION AND INSTALLATION
INSTRUCTIONS - REFER TO SECTION S

NOTE: PRODUCTS ON THIS PAGE ARE AVAILABLE
WITH TRIPLE LIP SEALS (SEE PAGE O-9)
TO ORDER ADD SUFFIX L3 (EXAMPLE
PB2515TWX1L3)

DOWNLOAD AVAILABLE CAD MODELS AT: WWW.HUBCITYINC.COM

Certified prints are available upon request

CALL: (605) 225-0360 • FAX: (605) 225-0567

Hub City CleanLine™ Bearing Units



CleanLine Plus™ Thermoplastic Composite Mounted Bearings Series PB251CTW - Pillow Blocks

Features:

- 440 Stainless Steel Rings and Balls
- 302 Stainless Steel Flingers and Retainers
- Setscrew Lock - Wide Inner Ring
- Factory Filled USDA H1 Lubricant Meets FDA Regulation 178.3570 Requirement for Incidental Contact with Food
- 304 Stainless Steel Setscrews
- Anti Rotation Pin
- Ultradur Glass Reinforced PBT Thermoplastic Housing
- Tensile Strength 16700 psi at Room Temperature
- Stainless Steel Bushings in All Bolt Holes
- Stainless Steel Insert for Zerk Threads
- Stainless Steel Zerks
- Moisture Resistant
- Corrosion Resistant
- Grooved for Composite Dust Caps on One Side, See Page O-13
- Smooth Surface with No Ribs for Easy Cleaning

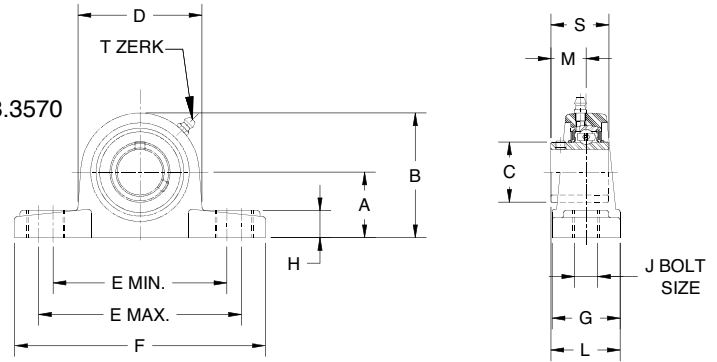

NOTE: PRODUCTS ON THIS PAGE ARE AVAILABLE WITH TRIPLE LIP SEALS (SEE PAGE O-9) TO ORDER ADD SUFFIX L3 (EXAMPLE PB251STWX1L3)

SHAFT SIZE	A	B	C	D	E MIN.	E MAX.	F	G	H	J	L	M	S	WT. LBS.
1/2, 5/8, 3/4	1.3120	2.5600	1.1400	2.7700	3.6600	3.8200	5.0000	1.5000	.5600	.4300	1.4700	.7200	1.2200	.07
7/8, 1	1.4380	2.8000	1.3400	3.0800	4.0100	4.2500	5.5100	1.5000	.5600	.5500	1.5300	.7790	1.3430	.07
1-1/8, 1-3/16, 1-1/4s	1.6880	3.2700	1.5900	3.6200	4.5600	4.8000	6.3800	1.8100	.6800	.5500	1.7800	.8740	1.5000	1.2
1-1/4, 1-3/8, 1-7/16	1.8750	3.7000	1.8900	3.9700	4.8800	5.1200	6.5700	1.8900	.7000	.5500	1.9400	1.0000	1.6890	1.6
1-1/2	1.9380	3.8600	2.0600	4.3600	5.2700	5.5100	7.2400	2.1300	.7700	.5500	2.2500	1.1890	1.9370	2.3

Part Numbers are specified by "PB251CTW" and Bore Size. Example: PB251CTW x 3/4.
For replacement inserts use B250TW Bearing Inserts, O-9.
T-Zerk: 1/4-28 Taper

For Load Ratings, See page O-10 & O-11.

Series TPB250CTW - Tapped Base Pillow Blocks



Features:
(same as above)

FOR LUBRICATION AND INSTALLATION
INSTRUCTIONS - REFER TO SECTION S

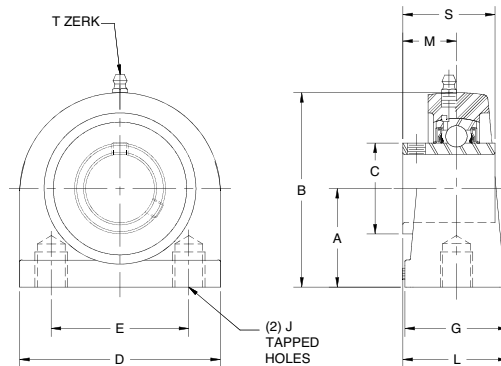

SHAFT SIZE	A	B	C	D	E	G	J - TAPPED HOLES	L	M	S	WT. LBS.
1/2, 5/8, 3/4	1.3120	2.6000	1.1400	2.8700	2.0000	1.5000	3/8-16UNC X .44	1.4700	.7200	1.2060	0.6
7/8, 1	1.4370	2.8300	1.3400	3.0000	2.0000	1.5000	3/8-16UNC X .47	1.5300	.7790	1.3430	0.7
1-1/8, 1-3/16, 1-1/4s	1.6870	3.3100	1.5900	4.0000	3.0000	1.5000	7/16-14UNC X .69	1.6200	.8740	1.5000	1.1
1-1/4, 1-3/8, 1-7/16	1.8750	3.7800	1.8900	4.3300	3.2500	1.8900	1/2-13UNC X .63	1.9500	1.0000	1.6890	1.6
1-1/2	1.9370	3.9800	2.0600	4.7200	3.5000	2.1300	1/2-13UNC X .63	2.2500	1.1890	1.9370	2.2

Part Numbers are specified by "TPB250CTW" and Bore Size. Example: TPB250CTW x 1.
For replacement inserts use B250TW Bearing Inserts, O-9.
T-Zerk: 1/4-28 Taper

For Load Ratings, See page O-10 & O-11.

¶ DIMENSIONS SHOWN ARE FOR REFERENCE ONLY.

DOWNLOAD AVAILABLE CAD MODELS AT: WWW.HUBCITYINC.COM

Certified prints are available upon request

EMAIL: hubsales@regalbeloit.com • www.hubcityinc.com



Hub City CleanLine™ Bearing Units

CleanLine UltraPlus™ Thermoplastic Composite Mounted Bearings



Series FB250CTW - Four Bolt Flange Blocks

Features:

- 440 Stainless Steel Rings and Balls
- 302 Stainless Steel Flingers and Retainers
- Setscrew Lock - Wide Inner Ring
- Factory Filled USDA H1 Lubricant Meets FDA Regulation 178.3570 Requirement for Incidental Contact with Food
- 304 Stainless Steel Setscrews
- Anti Rotation Pin
- Ultradur Glass Reinforced PBT Thermoplastic Housing
- Tensile Strength 16700 psi at Room Temperature
- Stainless Steel Bushings in All Bolt Holes
- Stainless Steel Insert for Zerk Threads
- Stainless Steel Zerks
- Moisture Resistant
- Corrosion Resistant
- Grooved for Composite Dust Caps on One Side, See Page O-37
- Smooth Surface with No Ribs for Easy Cleaning

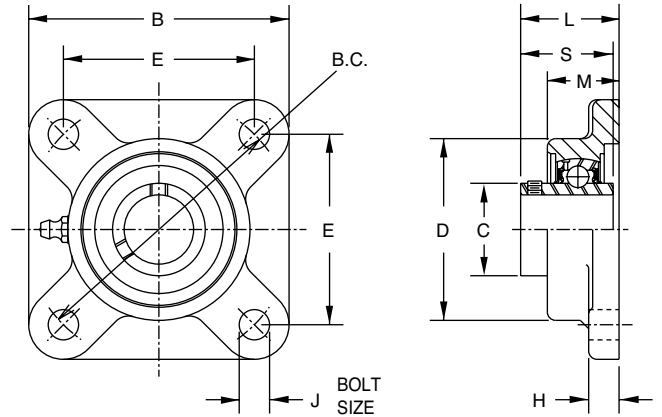

SHAFT SIZE	B	B.C.	C	D	E	H	J	L	M	S	WT. LBS.
1/2, 5/8, 3/4	3.3800	3.5630	1.1400	2.3600	2.5000	.5120	.4330	1.3110	1.1000	1.2200	.07
7/8, 1	3.7400	3.8980	1.3400	2.8000	2.7560	.5510	.4330	1.4060	1.1000	1.3420	.08
1-1/8, 1-3/16, 1-1/4s	4.2500	4.6220	1.5900	3.1900	3.2680	.5510	.4330	1.5830	1.2200	1.5000	1.1
1-1/4, 1-3/8, 1-7/16	4.6100	5.1220	1.8900	3.6200	3.6220	.5910	.5120	1.7480	1.3000	1.6890	1.6
1-1/2	5.1200	5.6790	2.0600	4.0900	4.0160	.6690	.5510	2.0160	1.5000	1.9370	2.3

Part Numbers are specified by "FB250CTW" and Bore Size. Example: FB250CTW x 3/4.
 For replacement inserts use B250TW Bearing Inserts, O-9
 T-Zerk: 1/4-28 Taper

For Load Ratings, See page O-10 & O-11.

Series FB260CTW - Two Bolt Flange Blocks

Features:
 (same as above)

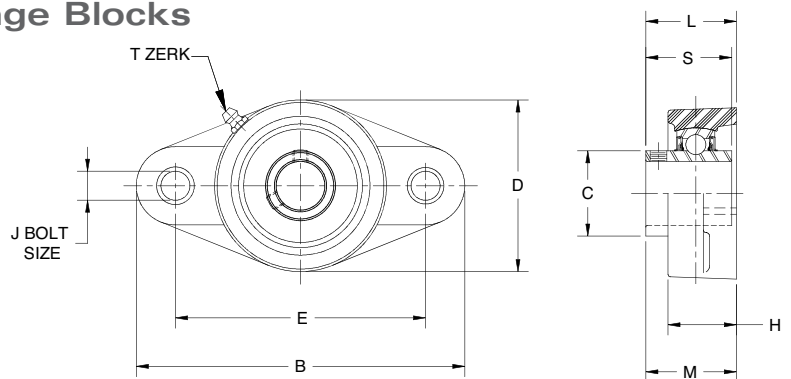

FOR LUBRICATION AND INSTALLATION INSTRUCTIONS - REFER TO SECTION S

SHAFT SIZE	B	C	D	E	H	J	L	M	S	WT. LBS.
1/2, 5/8, 3/4	4.4500	1.1400	2.3600	3.5430	.4300	.4330	1.3110	1.0400	1.2200	.06
7/8, 1	5.1200	1.3400	2.6800	3.8980	.5100	.4330	1.4050	1.1600	1.3420	.07
1-1/8, 1-3/16, 1-1/4s	5.8300	1.5900	3.1500	4.6060	.5100	.4330	1.5830	1.2000	1.5000	1.0
1-1/4, 1-3/8, 1-7/16	6.3400	1.8900	3.5400	5.1180	.6300	.5120	1.7480	1.2900	1.6890	1.4
1-1/2	6.8900	2.0600	3.9400	5.6690	.6700	.5510	2.0160	1.4800	1.9370	2.0

Part Numbers are specified by "FB260CTW" and Bore Size. Example: FB260CTW x 3/4.
 For replacement inserts use B250TW Bearing Inserts, O-9
 T-Zerk: 1/4-28 Taper

For Load Ratings, See page O-10 & O-11.

⚠ DIMENSIONS SHOWN ARE FOR REFERENCE ONLY.

DOWNLOAD AVAILABLE CAD MODELS AT: WWW.HUBCITYINC.COM

Certified prints are available upon request

CALL: (605) 225-0360 • FAX: (605) 225-0567

Hub City CleanLine™ Bearing Units CleanLine Plus™ and UltraPlus Bearing Inserts

Series B250TW - Stainless Steel Bearings

Features:

- 440 Stainless Steel Rings and Balls
- 302 Stainless Steel Retainers
- Setscrew Lock - Wide Inner Ring
- Factory Filled USDA HI Lubricant Meets FDA Regulation 178.3570 Requirement for Incidental Contact with Food
- Silicone Seals with 302 Stainless Steel Flingers
- Lube Groove for Relubrication. (Housing Groove Not Required)
- 304 Stainless Steel Setscrews
- Anti Rotation Pin

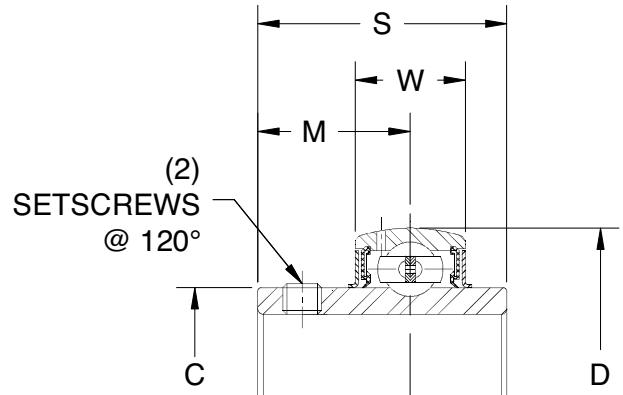

SHAFT SIZE	C	D	M	S	W	SETSCREW	WT. LBS.
1/2, 5/8, 3/4	1.1140	1.8504	0.7200	1.2200	0.6300	1/4 - 28UNF	0.4
7/8, 1	1.3390	2.0472	0.7790	1.3430	0.6690	1/4 - 28UNF	0.5
1-1/8, 1-3/16, 1-1/4s	1.5870	2.4409	0.8740	1.5000	0.7480	1/4 - 28UNF	0.7
1-1/4, 1-3/8, 1-7/16	1.8460	2.8346	1.0000	1.6890	0.7870	5/16-24UNF	1.0
1-1/2	2.0630	3.1496	1.1890	1.9370	0.8270	5/16-24UNF	1.5
1-5/8, 1-11/16, 1-3/4	2.2600	3.3465	1.1890	1.9370	0.8660	5/16-24UNF	1.6
1-15/16	2.4880	3.5433	1.2830	2.0310	0.9450	3/8-24UNF	1.8

Series B250TW L3 Triple Lip Seal - Stainless Steel Bearings

Features:

- 440 Stainless Steel Rings and Balls
- 302 Stainless Steel Retainers
- Setscrew Lock - Wide Inner Ring
- Factory Filled USDA HI Lubricant Meets FDA Regulation 178.3570 Requirement for Incidental Contact with Food
- Silicone Seals with 302 Stainless Steel Trash Guards
- Lube Groove for Relubrication. (Housing Groove Not Required)
- 304 Stainless Steel Setscrews
- Anti Rotation Pin

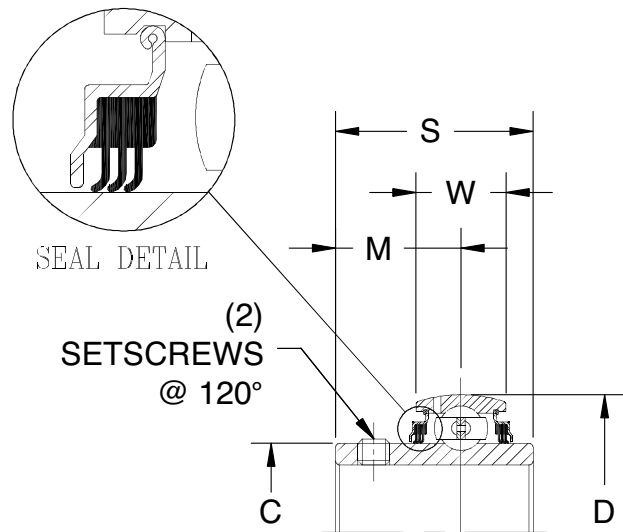

SHAFT SIZE	C	D	M	S	W	SETSCREW	WT. LBS.
1/2, 5/8, 3/4	1.1140	1.8504	0.7200	1.2200	0.6300	1/4 - 28UNF	0.4
7/8, 1	1.3390	2.0472	0.7790	1.3430	0.6690	1/4 - 28UNF	0.5
1-1/8, 1-3/16, 1-1/4s	1.5870	2.4409	0.8740	1.5000	0.7480	1/4 - 28UNF	0.7
1-1/4, 1-3/8, 1-7/16	1.8460	2.8346	1.0000	1.6890	0.7870	5/16-24UNF	1.0
1-1/2	2.0630	3.1496	1.1890	1.9370	0.8270	5/16-24UNF	1.5
1-5/8, 1-11/16, 1-3/4	2.2600	3.3465	1.1890	1.9370	0.8660	5/16-24UNF	1.6
1-15/16	2.4880	3.5433	1.2830	2.0310	0.9450	3/8-24UNF	1.8

DOWNLOAD AVAILABLE CAD MODELS AT: WWW.HUBCITYINC.COM

Certified prints are available upon request

EMAIL: hubsales@regalbeloit.com • www.hubcityinc.com



Hub City CleanLine™ Bearing Units

Series B250TW - CleanLine™ Stainless Steel Bearing Ratings

BEARING RADIAL LOAD CAPACITY (POUNDS) FOR 500 HOURS L-10 LIFE (2500 HOURS AVERAGE LIFE) AND STEADY LOAD CONDITIONS										
SHAFT SIZE (INCHES) 100, 200 SERIES	BASIC DYNAMIC RATING, C* (POUNDS)	BASIC STATIC RATING, Co** (POUNDS)	BEARING SPEED (RPM)							
			100	500	1,000	1,500	2,000	2,500	3,000	3,500
1/2 to 5/8	2200	1390	1,530	890	710	620	560	520	490	470
3/4	2200	1390	1,530	890	710	620	560	520	490	470
7/8 to 1	2430	1570	1,680	990	780	680	620	580	540	520
1-1/8 to 1-1/4S	3350	2250	2,320	1,360	1080	940	860	790	750	710
1-1/4 to 1-7/16	4430	3060	3,070	1,800	1430	1250	1130	1050	990	
1-1/2	5640	3990	3,910	2,290	1810	1590	1440	1340	1260	
1-11/16 to 1-3/4	5640	3990	3,910	2,290	1810	1590	1440	1340		
1-7/8 to 1-15/16	6060	4450	4,200	2,460	1950	1700	1550	1440		

* Radial load for an L-10 rating life of 1,000,000 revolutions.

** Radial load rating for stationary or very low speed operation.

For ultimate life, snug fit or light press fit on shaft should be used.

Recommended operating temperature range: 0 to +225 deg F.

For applications not covered in the rating tables, consult the factory. Ratings are based on ISO 281.

Maximum Recommended Speeds:

1/2 to 1-1/4S 3,500 RPM

1-1/4 to 1-1/2 3,000 RPM

1-5/8 to 1-15/16 2,500 RPM

TO MODIFY THE ABOVE RATINGS FOR OTHER L-10 LIFE REQUIREMENTS OR FOR SHOCK LOADS MULTIPLY THE ABOVE RATINGS BY THE FACTOR FROM THIS CHART														
MODIFICATION FACTORS FOR L-10 SERVICE LIFE AND LOAD CONDITIONS:														
LOAD CONDITIONS	L-10 LIFE (HOURS)													
	500	700	1,000	1,500	2,000	3,000	4,000	5,000	7,000	10,000	15,000	20,000	30,000	50,000
Steady Load	1.00	.894	.794	.694	.630	.550	.500	.464	.415	.368	.322	.292	.255	.215
Light Shock	.90	.804	.715	.624	.567	.495	.450	.418	.373	.331	.290	.263	.230	.194
Moderate Shock	.70	.626	.556	.485	.441	.385	.350	.325	.290	.258	.225	.205	.179	.151

DOWNLOAD AVAILABLE CAD MODELS AT: WWW.HUBCITYINC.COM

¶ DIMENSIONS SHOWN ARE FOR REFERENCE ONLY.







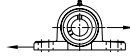
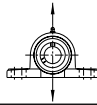

DOWNLOAD AVAILABLE CAD MODELS AT: WWW.HUBCITYINC.COM

Certified prints are available upon request

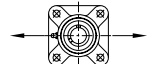
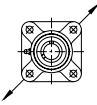
CALL: (605) 225-0360 • FAX: (605) 225-0567

Hub City CleanLine™ Bearing Units

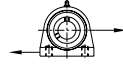
Load Ratings

BREAKING POINT TESTS OF COMPOSITE HOUSINGS AT ROOM TEMPERATURE (75 F.)						
	MODE OF LOAD	BREAKING STRENGTH (POUNDS)				
		1/2 TO 3/4	7/8 TO 1	1-1/8 TO 1-1/4S	1-1/4 TO 1-7/16	1-1/2
PB251CTW		2000	3100	2800	2900	2900
		1700	2200	2400	2400	2500
		1100	1800	1300	1700	1900
FB250CTW		2900	2900	3800	4200	4300
		2300	2700	4000	4200	4300
		730	750	760	790	850
FB260CTW		2500	2600	3700	3800	3900
		2500	3100	3000	3100	3200
		1900	2500	3200	3300	3400
TPB250CTW		1800	1900	2300	2700	2700
		1500	1600	1500	1800	2000
		670	640	1100	1800	2200

CleanLine™ Bearings

Recommended operating temperature of composite housings is 20 to 230 deg F.
Housing strength varies with operating temperature, and this must be considered in the selection and application of composite bearing units.

DOWNLOAD AVAILABLE CAD MODELS AT: WWW.HUBCITYINC.COM

Certified prints are available upon request

EMAIL: hubsales@regalbeloit.com • www.hubcityinc.com



Hub City CleanLine™ Bearing Units

UltraPlus™ Mounted Bearings

Accessories - Clearance Spacers

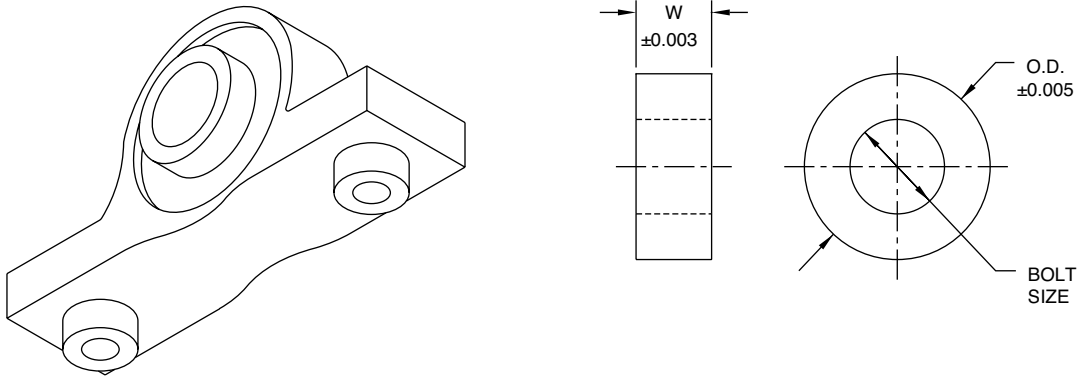

Clearance spacers are an excellent method of adding space between the mounted bearing and its mounting surface.

Clearance spacers minimize the surface contact area between the mounted bearing and its mounting surface to reduce potential bacterial growth areas.

Clearance spacers provide space for cleaning brushes to be used during sanitation processes. The spacers allow accessibility when cleaning by high-pressure washing or circulation of flowing chemical solutions, cleaning liquids and water rinses.

316 Stainless Steel Clearance Spacers

BOLT SIZE	SPACER NO.	O.D.	W
1/4	8471601286	0.625	0.375
5/16	8471601287	0.688	0.375
3/8	8471601288	0.812	0.375
7/16	8471601289	0.922	0.375
1/2	8471601290	0.969	0.375
5/8	8471601291	1.312	0.375

Order (1) spacer for each mounting hole required.
Consult factory for additional sizes available.

SUITABLE FOR:

CleanLine Pharmaceutical
CleanLine UltraPlus
CleanLine Plus
CleanLine Gear Drives

DOWNLOAD AVAILABLE CAD MODELS AT: WWW.HUBCITYINC.COM
Certified prints are available upon request

CALL: (605) 225-0360 • FAX: (605) 225-0567

Hub City CleanLine™ Bearing Units

UltraPlus™ Mounted Bearings

Accessories - Protective Caps

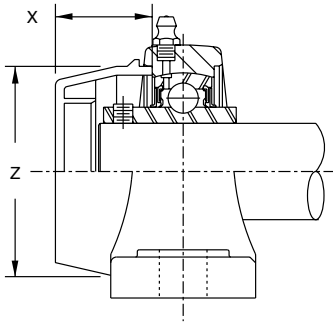

CLOSED PILLOW BLOCK UNITS

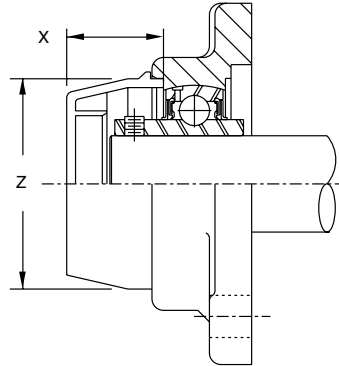

CLOSED FLANGE UNITS

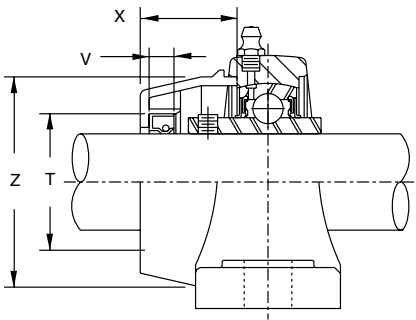

OPEN PILLOW BLOCK UNITS

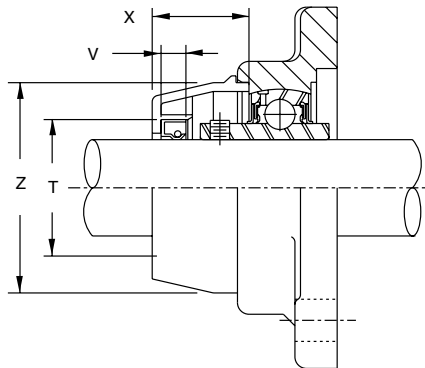

OPEN FLANGE UNITS



PROTECTIVE CAPS AND SEALS

SHAFT SIZE	T	V	X	Z	CLOSED CAP		OPEN CAP		SEAL FOR OPEN CAP	
					DESCRIPTION	PART NUMBER	DESCRIPTION	PART NUMBER	DESCRIPTION	PART NUMBER
1/2	1.260	0.28	29/32	1-31/32	CPCCx3/4	1540101016	CPOCx3/4	1540101007	CPSEALx1/2	1745011004
5/8									CPSEALx5/8	1745011005
3/4									CPSEALx3/4	1745011006
7/8	1.457	0.28	1	2-5/32	CPCCx1	1540101017	CPOCx1	1540101008	CPSEALx7/8	1745011019
1									CPSEALx1	1745011007
1-1/8									CPSEALx1-1/8	1745011008
1-3/16	1.654	0.28	1-3/16	2-1/2	CPCCx1-3/16	1540101018	CPOCx1-3/16	1540101009	CPSEALx1-3/16	1745011009
1-1/4S									CPSEALx1-1/4S	1745011010
1-1/4									CPSEALx1-1/4	1745011011
1-3/8	1.850	0.28	1-1/4	2-15/16	CPCCx1-7/16	1540101019	CPOCx1-7/16	1540101010	CPSEALx1-3/8	1745011012
1-7/16									CPSEALx1-7/16	1745011013
1-1/2									CPSEALx1-1/2	1745011014
1-1/2	2.047	0.28	1-15/32	3-5/16	CPCCx1-1/2	1540101020	CPOCx1-1/2	1540101011	CPSEALx1-1/2	1745011014

PROTECTIVE CAPS AND SEALS ARE SUITABLE FOR BOTH STAINLESS STEEL AND THERMOPLASTIC COMPOSITE BEARINGS
CAPS AND SEALS ARE SOLD SEPARATELY. ORDER BY DESCRIPTION OR PART NUMBERS SHOWN

DOWNLOAD AVAILABLE CAD MODELS AT: WWW.HUBCITYINC.COM

Certified prints are available upon request

EMAIL: hubsales@regalbeloit.com • www.hubcityinc.com



Hub City CleanLine™ Bearing Units

Modified and Custom Designs

If you have looked through this catalog and do not see exactly what you need, Hub City has the capability and engineering expertise to design and produce modified or custom mounted bearings.

Capabilities range as follows:

- Special sealing requirements or materials
- Special lubricants
- Housing modifications
- Special paint or housing coatings
- Modifications for specific or unique application requirements

Consult the factory or your Hub City representative with your specifications.

Hub City ModuLine™ Spherical Roller Bearing Units

ModuLine™ Spherical Roller Bearing Features	P-2
ModuLine™ Spherical Roller Bearing Engineering & Selection	P-4
ModuLine™ Pillow Block Dimensions (Type E Dimensional Equivalent).....	P-10
ModuLine™ Flange Block Dimensions (Type E Dimensional Equivalent).....	P-12
ModuLine™ Pillow Block Dimensions (Traditional Straight Bore Parameters).....	P-13
ModuLine™ Flange Block Dimensions (Traditional Straight Bore Parameters).....	P-15
ModuLine™ Spherical Roller Bearing Accessories	P-16
ModuLine™ Spherical Roller Bearing Interchange Guide.....	P-18

Hub City ModuLine™ Spherical Roller Bearing Units

Features and Benefits

- Modular design
- High Load Capacity
- Tolerates Misalignment up to 1-1/2°
- Mechanically and dimensionally interchangeable with most major brands
- Housing dimensions to match both Type-E and traditional straight bore units
- Pillow block housings are machined at each end to ease alignment at installation
- Three sealing options to guard against contamination
 - Double Lip or Triple Lip Nitrile contact seals, Teflon Labyrinth seals
- Inserts - 52100 bearing steel, through hardened races and rollers
- Cast steel housing
- Lifetime warranty against breakage on the housings (Standard Terms & Conditions apply)
- Easy field conversion from fixed to floating
- Bore sizes from 1-7/16" through 4-15/16"
- Includes grease fitting and grease purge ports



DOWNLOAD AVAILABLE CAD MODELS AT: WWW.HUBCITYINC.COM

CALL: (605) 225-0360 • FAX: (605) 225-0567

Hub City ModuLine™ Spherical Roller Bearing Units

Features - Seals and Covers

Double Lip Nitrile Seal

- Non-purging, Recommended for heavy moisture and gritty materials.
- Not recommended for most chemical contaminants.
- Typical applications include ground contact equipment, agricultural machinery, etc.

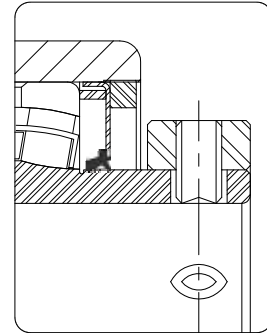

Triple Lip Nitrile Seal

- Purgeable, good for large particulate contamination, and moisture.
- Not recommended for most chemical contaminants.
- Typical applications include sawmills, forestry equipment etc.

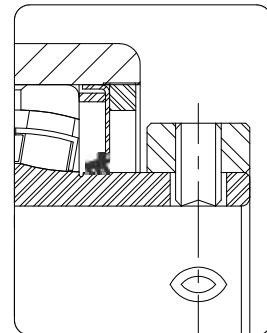

Labyrinth Teflon Seal

- Labyrinth Teflon seals are non-purging, and low drag.
- Suitable for all speeds, high temperature, and moisture.
- PTFE (Teflon) is non-reactive to most chemicals.
- Labyrinth Teflon seals are recommended for most industrial applications.

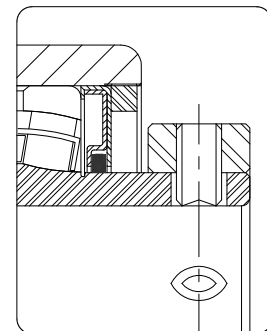

Covers

Closed Covers

- Closed covers are designed to completely seal the exposed end of a rotating shaft. These heavy duty metal covers fasten to the bearing lock ring and are equipped with a grease fitting so the entire cavity can be filled with grease, effectively limiting fretting corrosion between bearing bore and shaft.



Open Covers

- Open covers allow the shaft to pass through the cover while providing an auxiliary labyrinth Teflon seal on the shaft. These heavy duty metal covers fasten to the bearing lock ring and are equipped with a grease fitting so the entire cavity can be filled with grease, effectively limiting fretting corrosion between bearing bore and shaft.



DOWNLOAD AVAILABLE CAD MODELS AT: WWW.HUBCITYINC.COM

Hub City ModuLine™ Spherical Roller Bearing Units

Engineering and Selection Information

Maximum Speed

Maximum speed limits listed for the ModuLine™ Spherical Roller Bearing units described in this catalog should be used as a guide and considered along with other factors affecting bearing operation. Load characteristics, bearing lubrication, and temperature factors all influence bearing operation. It is possible that cataloged speed limits may be exceeded after a complete application analysis is completed by factory engineers.

Bearing Life

Bearing life is commonly referred to in terms of the number of hours of operation, at a given load and speed that 90% of the bearings in a lot can equal or exceed before the onset of fatigue failure. This is called the L-10 life of a bearing.

Bearing Loads

Radial loads and axial (thrust) forces in combination are the principal load components of bearing applied loads. Hub City bearing unit ratings are based upon the radial load capacity of the bearing. Spherical roller bearings are designed to handle significant radial loads even when combined with a thrust load. However, these bearings are not generally recommended for use in applications where only thrust forces are present or when thrust loads exceed the radial loading of the bearing.

The charts on page P4 and P-7 are to be used when only radial loads are present, or once the combined equivalent load value is calculated. For applications where bearings are required to absorb thrust forces in addition to normal radial loads, the following considerations must be made concerning the magnitude of the thrust force.

1. When thrust loads are less than 25% of the radial load the equivalent load is determined by adding the radial and thrust loads together. The bearing selection is based upon using this total load as the equivalent applied radial load.
2. When thrust loads are equal to or greater than 25% of the radial load – the application must be reviewed by the factory.

Table 1: Basic Radial loads

Shaft Size (in)	Dynamic Load C_r Capacity (Lb.)	Static Load C_{Or} Capacity (Lb.)
1-7/16 1-1/2	20200	22500
1-11/16 1-3/4	21150	24320
1-15/16 2	22500	27150
2-3/16 2-1/4	27300	31940
2-7/16 2-1/2	39800	48600
2-11/16 2-3/4 2-15/16 3	43020	53980
3-7/16 3-1/2	68550	87700
3-15/16 4	85500	108980
4-7/16	108000	144050
4-15/16	124500	186250

Bearing Selection

Selection of the proper Hub City bearing unit for a determined speed and load can be made by referring to the load rating tables. Proper selection is made by finding a bearing having the desired bore size which has a load rating equal to or greater than the radial or equivalent radial load required for the application.

Engineering Data

Bearing reaction loads are caused by forces acting on the shaft supported by the bearings. These forces are a result of the weight of the shafting and components mounted on the shafting, bending loads due to belt or chain pull, gear reaction loads, and off center or unbalanced loads. These loads must be combined into a single resultant load of known magnitude and direction for each bearing. Whether the load is applied between bearings on a shaft supported by two bearings or outboard of one of the bearings is important to proper bearing selection. The magnitude and direction of the load for either case may be calculated by taking moments about the other bearing.

Hub City ModuLine™ Spherical Roller Bearing Units

Engineering and Selection Information

Minimum Loads

Although it may be a rare application where little or no loads are present, spherical roller bearings must have proper loads present in the application in order to function satisfactorily. Radial loads less than 3% of C_r (see page P-4) should be avoided.

Misalignment

All Hub City ModuLine™ Spherical Roller Bearing units can accept up to 1-1/2 degrees misalignment.

Lubrication

The proper lubrication of bearing units is critical in order to attain maximum bearing life expectancy. HUB CITY SPHERICAL ROLLER BEARINGS are factory filled with Ulti-Plex® Synthetic EP Grease, which is a multipurpose, high performance grease specially formulated for extreme pressure bearing applications operating under the most extreme high and low temperature conditions and for those difficult applications requiring extended lubrication intervals. This grease offers excellent thermal stability through temperatures ranging from -50° F to 400° F (-50° to 230° C). When dealing with temperatures above 300° F, consult the factory for optional grease recommendations. All Hub City bearing units are lubricated at the factory and should not require additional lubricant upon installation. Re-lubrication intervals noted in Table 3 are to be used as a general guide and depend on the type of application, speed, operating temperature and other environmental conditions. The amount and type of lubricant used will affect bearing life. Improper lubrication can lead to premature bearing failures. For unusual lubrication requirements or severe duty applications, contact Hub City for recommendations.

Seal Limiting Speeds (RPM)

Shaft Size (in)	Nitrile Contact Seal	Labyrinth Seal
1-7/16 1-1/2	2000	4000
1-11/16 1-3/4	2000	4000
1-15/16 2	1800	3600
2-3/16 2-1/4	1600	3200
2-7/16 2-1/2	1200	2800
2-11/16 2-3/4 2-15/16 3	1200	2400
3-7/16 3-1/2	1000	2000
3-15/16 4	900	1600
4-7/16	700	1200
4-15/16	500	1000

Ordering information - Example

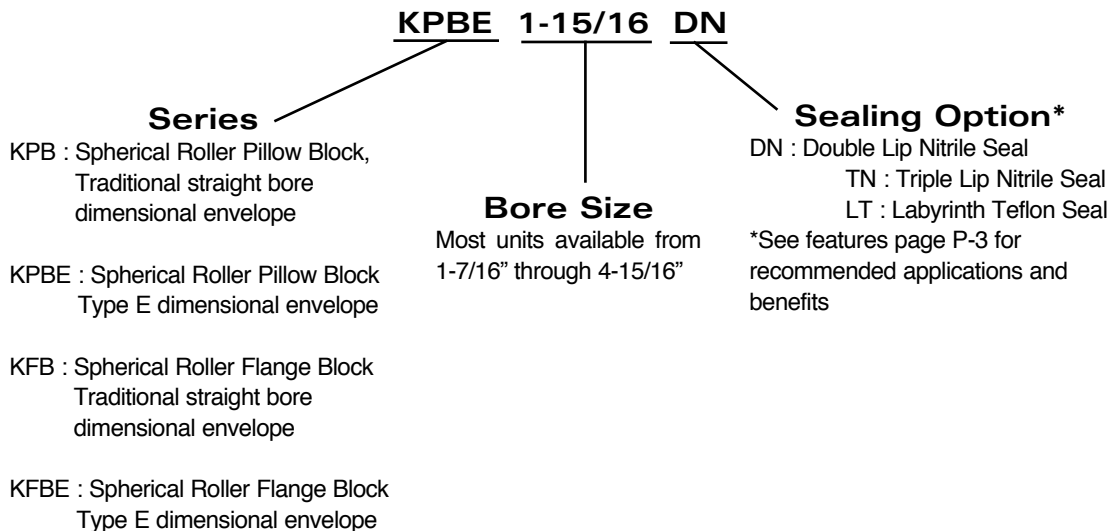

DOWNLOAD AVAILABLE CAD MODELS AT: WWW.HUBCITYINC.COM

Hub City ModuLine™ Spherical Roller Bearing Units

Engineering and Selection Information

PROCEDURE TO CONVERT SPHERICAL ROLLER BEARING FROM FIXED TO FLOATING (NON-EXPANSION TO EXPANSION)

FLANGE BLOCK HOUSING

1. Make a reference mark on the housing and retaining nut.
2. Loosen set screws in housing that lock the retaining nut in place.
3. Loosen retaining nut by tapping with a hammer and punch, rotating retaining nut counter clockwise one complete revolution.
4. Tighten set screws in housing to lock retaining nut in place.

Please note: When converting a Spherical Roller bearing from fixed to floating, please ensure that the bearing is correctly oriented. A bearing that has been converted to expansion can only float in the direction of the loosened retaining nut.

PILLOW BLOCK HOUSING

1. Determine amount and direction of expansion needed. If uni-directional expansion is required, follow above directions on the nut that is on the side where expansion is desired
2. If bi-directional expansion is required follow the directions above on both nuts but the rotation should be one-half a revolution on each nut instead of one complete revolution.

PROCEDURE TO CONVERT SPHERICAL ROLLER BEARING FROM FLOATING TO FIXED (EXPANSION TO NON-EXPANSION)

FLANGE BLOCK HOUSING

1. Loosen set screws in housing that lock the retaining nut in place.
2. Tighten retaining nut by tapping with a hammer and punch, rotating retaining nut clockwise until tight. It is not possible to over-tighten the retaining nut.
3. Tighten set screw in housing to lock retaining nut in place.

PILLOW BLOCK HOUSING

1. Follow directions above on both nuts on either side of the housing.

Please Note: When converting from floating to fixed on a bearing that is mounted in the application, the set screws on the collars must be loosened to allow the insert to move in the housing and on the shaft.

Hub City ModuLine™ Spherical Roller Bearing Units

Load Ratings

Radial and Equivalent Load Ratings By Operating Speed

Shaft Size (in)	Life Hrs	Operating Speed (RPM)										
		50	100	200	500	1000	1200	1500	1800	2400	3000	3500
1-7/16 1-1/2	5000	8997	7257	5906	4487	3648	3478	3260	3079	2833	2637	2515
	10000	7308	5894	4798	3644	2963	2825	2647	2501	2301	2141	2043
	20000	5936	4788	3896	2960	2407	2294	2150	2032	1870	1739	1659
	50000	4509	3637	2960	2248	1828	1743	1633	1544	1420	1322	1261
	100000	3662	2954	2405	1827	1485	1416	1327	1253	1153	1073	1024
1-11/16 1-3/4	5000	9398	7580	6169	4686	3810	3633	3405	3217	2959	2754	2627
	10000	7633	6157	5011	3807	3095	2951	2765	2613	2404	2237	2134
	20000	6200	5001	4070	3092	2514	2397	2246	2123	1952	1817	1733
	50000	4709	3799	3092	2349	1909	1821	1706	1612	1484	1380	1317
	100000	3826	3085	2511	1907	1551	1479	1386	1310	1205	1121	1069
1-15/16 2	5000	9996	8062	6562	4985	4053	3864	3621	3422	3148	2930	2795
	10000	8119	6549	5330	4049	3292	3139	2941	2779	2557	2380	2270
	20000	6595	5319	4329	3289	2674	2550	2390	2257	2077	1933	1844
	50000	5010	4041	3289	2498	2031	1937	1815	1715	1578	1468	1401
	100000	4069	3283	2671	2029	1650	1573	1474	1393	1281	1193	1137
2-3/16 2-1/4	5000	12131	9785	7963	6050	4918	4689	4395	4153	3820	3556	3391
	10000	9854	7947	6469	4913	3995	3809	3570	3373	3103	2888	2754
	20000	8003	6456	5254	3991	3245	3093	2899	2740	2521	2346	2237
	50000	6080	4903	3991	3032	2465	2351	2202	2081	1915	1782	1699
	100000	4938	3983	3242	2463	2002	1910	1789	1690	1555	1447	1381
2-7/16 2-1/2	5000	17693	14271	11615	8823	7175	6840	6410	6056	5572	5187	
	10000	14372	11592	9435	7167	5827	5556	5206	4919	4526	4212	
	20000	11673	9416	7663	5821	4734	4512	4228	3996	3676	3421	
	50000	8868	7153	5821	4423	3596	3428	3212	3035	2793	2599	
	100000	7203	5810	4729	3592	2920	2785	2609	2465	2268	2111	
2-11/16 2-3/4 2-15/16 3	5000	19094	15401	12534	9522	7742	7382	6917	6536	6014		
	10000	15509	12509	10181	7735	6288	5996	5618	5308	4885		
	20000	12597	10161	8270	6282	5108	4890	4564	4312	3967		
	50000	9570	7719	6282	4773	3880	3699	3467	3275	3014		
	100000	7774	6269	5103	3876	3152	3005	2816	2661	2448		
3-7/16 3-1/2	5000	30492	24593	20017	15205	12363	11788	11046	10437	9603		
	10000	24766	19977	16258	12351	10042	9575	8972	8477	7800		
	20000	20117	16225	13206	10032	8157	7777	7288	6886	6335		
	50000	15282	12326	10032	7621	6197	5907	5536	5231	4813		
	100000	12413	10012	8148	6190	5033	4799	4496	4249	3909		
3-15/16 4	5000	37989	30641	24938	18944	15403	14685	13762	13004			
	10000	30857	24888	20256	15388	12511	11928	11178	10563			
	20000	25064	20215	16452	12498	10163	9689	9079	8580			
	50000	19039	15357	12498	9494	7720	7361	6897	6517			
	100000	15465	12473	10152	7712	6270	5979	5602	5293			
4-7/16	5000	47981	38700	31497	23927	19454	18548	17382	16424			
	10000	38972	31434	25584	19435	15802	15066	14118	13340			
	20000	31655	25533	20780	15786	12835	12237	11468	10836			
	50000	24047	19396	15786	11992	9750	9296	8712	8231			
	100000	19532	15755	12822	9741	7920	7551	7076	6686			
4-15/16	5000	55228	44546	36256	27542	22393	21350	20007				
	10000	44860	36183	29448	22371	18189	17341	16251				
	20000	36438	29389	23920	18170	14774	14086	13200				
	50000	27680	22326	18170	13803	11224	10700	10028				
	100000	22483	18134	14760	11212	9116	8691	8145				

These ratings are published as a guide only. Actual bearing life can be influenced by many factors including contamination, speed, loading, vibration etc. For help in determining actual application life, please consult factory."

DOWNLOAD AVAILABLE CAD MODELS AT: WWW.HUBCITYINC.COM

Certified prints are available upon request

EMAIL: hubsales@regalbeloit.com • www.hubcityinc.com



Hub City ModuLine™ Spherical Roller Bearing Units

Chemical Compatibility of Seal Materials

A - Little to no effect B - Minor to moderate effect C - Severe effect to destruction N - No data. Test prior to use				
Chemical	Urethane	Nitrile	Viton	Teflon
Acetaldehyde	C	C	C	A
Acetamide	N	A	B	A
Acetic Acid	C	B	B	A
Acetic Anhydride	C	C	C	A
Acetone	C	C	C	A
Acetyl Bromide	C	N	N	N
Acetyl Chloride	C	C	A	A
Acetylene	C	A	A	A
Adipic Acid	A	A	N	A
Aeor Shell Grease	B	A-B	A	A
Aero Lubriplate	A	A	A	A
Aero Safe 2300	N	C	C	A
Aerozene 50	N	C	C	A
Aluminum Acetate	N	A	C	A
Aluminum Bromide	N	A	A	A
Aluminum Chloride	B	A	A	A
Aluminum Sulfate	B	A	A	A
Ammonia	B	B	C	A
Ammonium Carbonate	B	C	N	A
Ammonium Chloride	N	A	A	A
Ammonium Hydroxide	B	C	A	A
Ammonium Nitrate	B	A	N	A
Ammonium Persulfate	B	C	N	A
Ammonium Sulfate	B	A	C	A
Ammonium Sulfide	B	A	C	A
Ammonium Thiocyanate	B	N	N	A
Ammonium Acetate	C	N	N	A
Amyl Acetate	C	C	C	A
Amyl Alcohol	C	B	C	A
Aniline	C	C	C	A
Aniline Hydrochloride	C	B	B	B
Animal Fats & Oils	B	A	A	A
Antimony Salts	B	N	N	A
Aqua Regia	C	C	B	A
Arsenic Salts	B	N	N	A
ASTM Oil #1	A	A	A	A
ASTM Oil #2	B	A	A	A
ASTM Oil #3	B	A	A	A
ASTM Reference Fuel	A	A	A	A
ASTM Reference Fuel	B	B	A	A
Atlantic Oil	A	A	A	A
Barium Carbonate	B	A	A	A
Barium Hydroxide	A	A	A	A
Beer	A	A	A	A
Benzaldehyde	B	C	C	A
Benzene	C	C	B	A
Benzoic Acid	B	C	A	A
Black Sulphate Liquors	N	B	A	A
Bleach Solutions	N	C	A	B

A - Little to no effect B - Minor to moderate effect C - Severe effect to destruction N - No data. Test prior to use				
Chemical	Urethane	Nitrile	Viton	Teflon
Boric Acid	A	A	A	A
Brake Fluid	N	C	C	N
Bromine	B	C	A	C
Bunker Oil	A	A	A	A
Butane	A	A	A	A
Butyl Acetate	C	C	C	A
Butyl Alcohol	B	A	A	A
Calcium Carbonate	B	A	A	A
Calcium Chloride	A	A	A	A
Calcium Hydroxide	A	A	A	A
Calcium Nitrate	B	A	A	A
Calcium Sulfate	B	B	B	A
Carbon Dioxide	A	A	A	A
Carbon Disulfide	B	C	A	A
Carbon Monoxide	A	A	A	A
Carbon Tetrachloride	C	C	A	A
Chlorine	N	C	A	B
Chloroacetic Acid	C	C	C	N
Chloroform	C	N	N	B
Chromic Acid	C	C	A	B
Chromium Potassium Sulfate	A	N	N	N
Citric Acid	B	A	A	A
Corn Oil	A	A	A	A
Cottonseed Oil	A	A	A	A
Cresol	C	C	A	A
Crude Oil	B	B	A	A
Cupric Chloride	A	B	B	A
Cupric Nitrate	B	N	N	A
Cupric Sulfate	B	B	B	A
Cutting Oil	B	A	A	A
Cyclohexane	B	A	A	A
Cyclohexanone	C	C	A	A
Dibutyl Phthalate	C	C	C	B
Dichlorobenzene	C	N	N	B
Diesel Fuel	B	A	A	A
Diester Oil	B	B	A	A
Dimethyl Acetamide	C	N	N	A
Dimethyl Formamide	C	B	C	A
Dodecyl Mercaptan	B	N	N	N
DTE Oil	B	A	N	N
Dubutyl Ether	B	C	C	N
EP Lubes	A	A	A	A
Esso #90 Lube Oil	A	A	A	A
Ether	B	N	N	A
Ethyl Acetate	C	C	C	A
Ethyl Alcohol (Ethanol)	C	A	C	A
Formic Acid	C	B	C	A
Freon, 12 or 113	A	A	B	A
Fuel Oil	B	A	A	A

DOWNLOAD AVAILABLE CAD MODELS AT: WWW.HUBCITYINC.COM

Hub City ModuLine™ Spherical Roller Bearing Units

Chemical Compatibility of Seal Materials

A - Little to no effect				
B - Minor to moderate effect				
C - Severe effect to destruction				
N - No data. Test prior to use				
Chemical	Urethane	Nitrile	Viton	Teflon
Gasoline	B	B	A	A
Glucose	A	A	A	A
Glue	N	A	A	A
Glycerin	A	A	A	A
Heptane	A	N	N	A
Hexane	A	A	A	A
Hydrazine	C	B	C	B
Hydrobromic Acid	B	C	A	A
Hydrocarbon Oil	A	A	A	A
Hydrochloric Acid	B	C	B	A
Hydrofluoric Acid	B	C	C	A
Hydrogen	A	A	A	A
Hydrogen Peroxide	B	C	A	B
Hydrogen Sulfide	C	C	C	A
Hydrologic Acid	B	N	N	N
Iodine	A	B	A	A
Isobutyl Alcohol	N	B	A	A
Isopropyl Chloride	N	C	A	A
Isopropyl Ether	B	B	C	N
Isopropyl Alcohol (Propanol)	B	A	A	N
JP4 Oil	B	A	A	A
JP5 & 6 Oil	C	A	A	A
Kerosene	B	A	A	A
Lactic Acid	B	B	A	A
Lead Acetate	B	B	C	A
Linseed Oil	B	A	A	A
Liquefied Petroleum Gas	A	A	A	N
Lubrication Oil	B	A	A	A
Lye	N	B	B	A
Magnesium Chloride	N	A	A	A
Magnesium Hydroxide	A	B	A	A
Magnesium Salts	B	A	A	A
Malaic Acid	C	C	A	A
Mercury	B	A	A	A
Methyl Alcohol (methanol)	A	C	A	N
Methyl Ethyl Ketone	C	C	C	A
Methylene Chloride	C	C	B	A
MIL-D-5606 Oil	C	A	A	A
MIL-L7808 Oil	B	B	A	A
Mineral Oil	A	A	A	A
Mineral Spirits	N	B	A	A
Naphthalene	B	C	A	A
Natural Gas	B	A	A	A
Nickel Salts	C	A	A	A
Oxygen	A	B	A	A
Ozone	A	C	A	A
Paimitic Acid	A	A	A	A
Paint Thinner	B	C	B	A
Peanut Oil	A	A	A	A

A - Little to no effect				
B - Minor to moderate effect				
C - Severe effect to destruction				
N - No data. Test prior to use				
Chemical	Urethane	Nitrile	Viton	Teflon
Perchloric Acid	C	C	A	A
Perchloroethylene	C	B	A	A
Petroleum	B	A	A	A
Phenol (carbolic acid)	C	C	A	A
Phosphoric Acid	C	C	A	A
Potassium Cyanide	A	A	A	A
Potassium Salts	B	A	A	A
Propane	B	A	A	A
Propyl Alcohol	B	A	A	A
Propylene Glycol	B	N	N	A
Pydraul Oil	C	C	A	A
SAE #10 Oil	A	A	A	A
Seawater	A	A	A	A
Silicic Acid	B	N	N	A
Silver Nitrate	B	B	A	A
Skydrol Oil	C	C	C	A
Soap	B	A	A	A
Sodium Acetate	A	B	C	A
Sodium Bicarbonate	B	A	A	A
Sodium Borate	B	A	A	A
Sodium Carbonate	B	A	A	A
Sodium Chloride	B	A	A	A
Sodium Cyanide	B	A	A	A
Sodium Hydrosulfite	B	N	N	A
Sodium Hydroxide	B	B	B	A
Sodium Hypochlorite	C	B	A	A
Sodium Nitrate	B	B	N	A
Sodium Silicate	A	A	A	A
Sodium Sulfate	B	A	A	A
Sodium Sulfide	B	A	A	A
Steam	C	C	C	A
Styrene	B	C	B	A
Sulfur Dioxide	B	C	A	A
Sulfuric Acid	C	C	A	A
Tannic Acid	A	A	A	A
Tartaric Acid	A	A	A	A
Toluene	C	N	N	A
Transformer Oil	B	N	N	A
Turpentine	C	A	A	A
Urea	B	N	N	A
Varnish	B	B	A	A
Water	B	A	A	A

Hub City ModuLine™ Spherical Roller Bearing Units

Traditional Straight Bore Dimensions - Model KPB

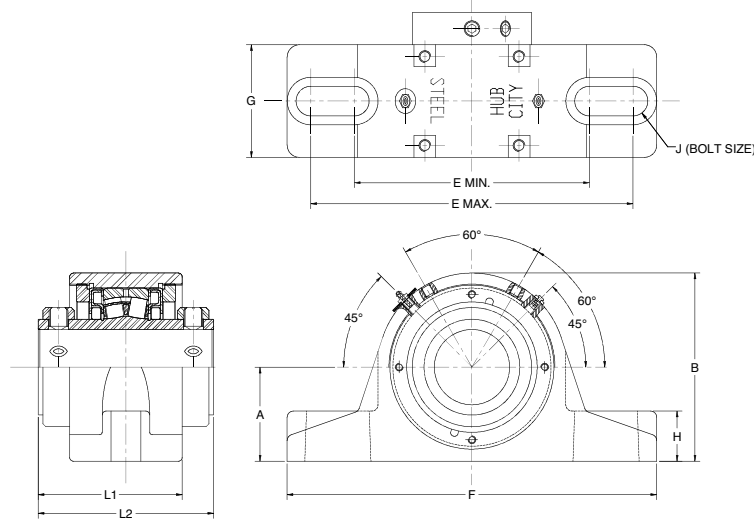

Note: Dimensions $\frac{\text{in}}$
Shown are: $\frac{\text{mm}}$

Note: Shaft sizes 2-15/16" and up have a dual locking collar, L2 dimension applies.

Bearing bore size tolerances are as follows:
1.4375 to 2.500 +.001/-0
2.6875 to 4.9375 +.0015/-0

Two Bolt Pillow Blocks

DESCRIPTION	BORE SIZE	SET-SCREW	A	B	E (MIN)	E (MAX)	F	G	H	J (BOLT SIZE)	L1	L2	
KPB1-7/16*	1.4375	3/8-24 UNF	1.875	3.75	4.69	5.31	6.87	2.24	1.00	1/2	2.87		
KPB1-1/2L*	1.5000		[47.63]	[95.3]	[119.0]	[134.9]	[174.6]	[57.0]	[25.4]		[73.0]		
KPB1-11/16*	1.6875	3/8-24 UNF	2.125	4.13	5.25	5.81	7.13	2.24	1.00	1/2	3.00		
KPB1-3/4*	1.7500		[53.98]	[105.0]	[133.4]	[147.6]	[181.0]	[57.0]	[25.4]		[76.1]		
KPB1-15/16*	1.9375	3/8-24 UNF	2.250	4.50	5.94	6.56	8.13	2.24	1.22	5/8	3.00		
KPB2*	2.0000		[57.15]	[114.3]	[150.8]	[166.7]	[206.4]	[57.0]	[31.0]		[76.1]		
KPB2-3/16*	2.1875	3/8-24 UNF	2.500	5.00	6.50	7.06	8.87	2.36	1.22	5/8	3.18		
KPB2-1/4*	2.2500		[63.50]	[127.0]	[165.1]	[179.4]	[225.4]	[60.0]	[31.0]		[80.8]		
KPB2-7/16*	2.4375	1/2-20 UNF	2.750	5.50	6.81	7.44	9.25	2.80	1.38	5/8	3.52		
KPB2-1/2*	2.5000		[69.85]	[139.7]	[173.0]	[188.9]	[235.0]	[71.0]	[35.0]		[89.5]		
KPB2-11/16*	2.6875	1/2-20 UNF								3/4	3.84		
KPB2-3/4*	2.7500		[82.55]	[161.9]	[196.0]	[214.0]	[265.1]	[74.2]	[35.0]		[97.4]		
KPB2-15/16*	2.9375											4.75	
KPB3*	3.0000		[120.7]									[120.7]	
KPB3-7/16*	3.4375	1/2-20 UNF	3.750	7.50	9.25	10.75	13.00	3.50	1.85	7/8		5.19	
KPB3-1/2*	3.5000		[95.25]	[190.5]	[235.0]	[273.0]	[330.2]	[88.9]	[47.0]		[131.7]		
KPB3-15/16*	3.9375	5/8-18 UNF	4.250	8.50	10.00	12.88	15.25	3.74	2.00	1		5.94	
KPB4*	4.0000		[107.95]	[215.9]	[254.0]	[327.2]	[387.4]	[95.0]	[50.8]		[150.8]		

* Specify Seal Design and Material

LT: Labyrinth Teflon (std)

DN: Double Lip Nitrile

TN: Triple Lip Nitrile

See pages P-3 and P-5 for more information

DOWNLOAD AVAILABLE CAD MODELS AT: WWW.HUBCITYINC.COM

Certified prints are available upon request

CALL: (605) 225-0360 • FAX: (605) 225-0567

Hub City ModuLine™ Spherical Roller Bearing Units

Traditional Straight Bore Dimensions - Model KPB

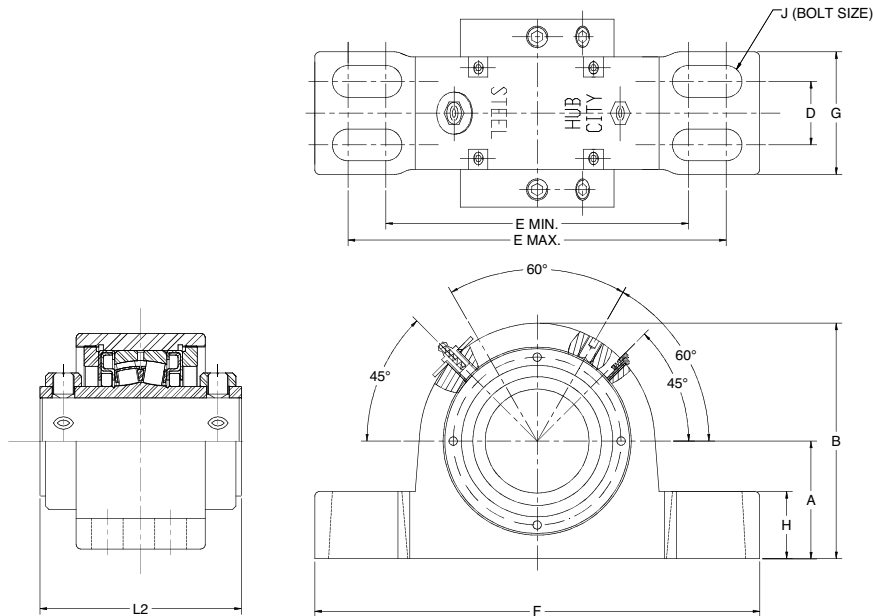

Note: Dimensions $\frac{\text{in}}$
Shown are: $\frac{\text{mm}}$

Bearing bore size tolerances are as follows:
1.4375 to 2.500 +.001/-0
2.6875 to 4.9375 +.0015/-0

Four Bolt Pillow Blocks

DESCRIPTION	BORE SIZE	SET-SCREW	A	B	D	E (MIN)	E (MAX)	F	G	H	J (BOLT SIZE)	L2
KPB4-7/16*	4.4375	5/8-18 UNF	4.750 [120.65]	9.70 [246.4]	2.50 [63.5]	13.00 [330.2]	14.00 [355.6]	15.88 [403.3]	4.72 [120.0]	2.00 [50.8]	3/4	6.13 [155.6]
KPB4-15/16*	4.9375	5/8-18 UNF	5.500 [139.70]	10.98 [279.0]	2.76 [70.0]	15.00 [381.0]	16.00 [406.4]	18.63 [473.1]	5.12 [130.0]	2.00 [50.8]	7/8	6.63 [168.3]

* Specify Seal Design and Material

LT: Labyrinth Teflon (std)

DN: Double Lip Nitrile

TN: Triple Lip Nitrile

See pages P-3 and P-5 for more information

Hub City ModuLine™ Spherical Roller Bearing Units

Traditional Straight Bore Dimensions - Model KFB

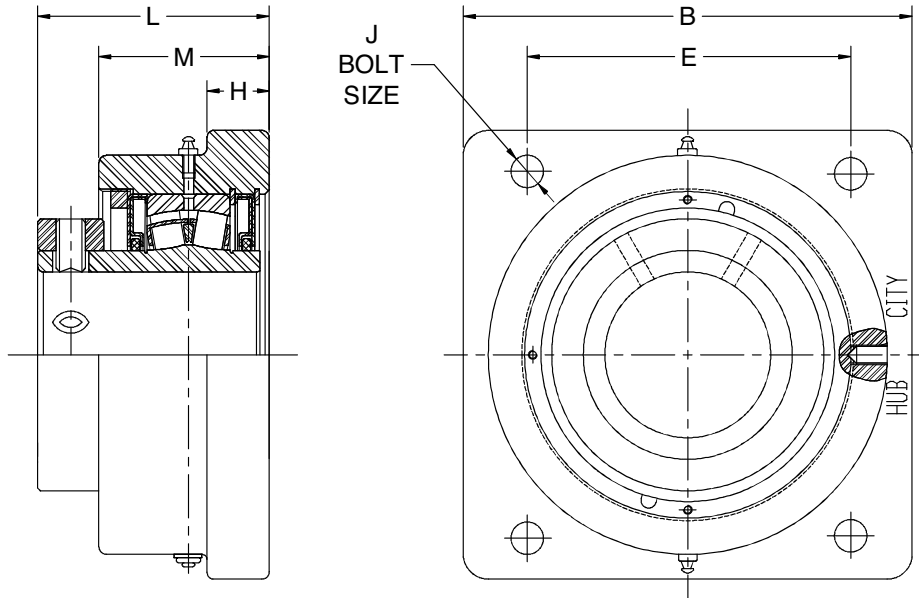

Bearing bore size tolerances are as follows:
 1.4375 to 2.500 +.001/-0
 2.6875 to 4.9375 +.0015/-0

Note: Dimensions $\frac{\text{in}}$
 Shown are: $\frac{\text{mm}}$

Four Bolt Flange Blocks

DESCRIPTION	BORE SIZE	SET-SCREW	B	E	H	J (BOLT SIZE)	L	M
KFB1-7/16*	1.4375	3/8-24 UNF	4.63 [117.5]	3.53 [89.7]	0.63 [16.0]	1/2	2.87 [73.0]	2.13 [54.0]
KFB1-1/2*	1.5000							
KFB1-11/16*	1.6875	3/8-24 UNF	5.37 [136.5]	3.89 [98.8]	0.63 [16.0]	1/2	2.99 [76.0]	2.20 [56.0]
KFB1-3/4*	1.7500							
KFB1-15/16*	1.9375	3/8-24 UNF	5.19 [131.8]	4.06 [103.2]	0.63 [16.0]	1/2	2.99 [76.0]	2.20 [56.0]
KFB2*	2.0000							
KFB2-3/16*	2.1875	3/8-24 UNF	5.87 [149.2]	4.50 [114.3]	0.79 [20.0]	5/8	3.24 [82.4]	2.44 [62.0]
KFB2-1/4*	2.2500							
KFB2-7/16*	2.4375	1/2-20 UNF	6.19 [157.2]	4.76 [121.0]	0.87 [22.0]	5/8	3.49 [88.7]	2.72 [69.0]
KFB2-1/2*	2.5000							
KFB2-11/16*	2.6875	1/2-20 UNF	7.19 [182.6]	5.56 [141.3]	0.87 [22.0]	3/4	3.74 [95.1]	2.72 [69.0]
KFB2-3/4*	2.7500							
KFB2-15/16*	2.9375							
KFB3*	3.0000							
KFB3-7/16*	3.4375	1/2-20 UNF	8.37 [212.7]	6.72 [170.7]	0.94 [24.0]	3/4	4.15 [105.4]	3.11 [79.0]
KFB3-1/2*	3.5000							
KFB3-15/16*	3.9375	5/8-18 UNF	9.50 [241.3]	7.59 [192.9]	1.10 [28.0]	1	4.71 [119.7]	3.50 [89.0]
KFB4*	4.0000							

* Specify Seal Design and Material
 LT: Labyrinth Teflon (std)
 DN: Double Lip Nitrile
 TN: Triple Lip Nitrile
 See pages P-3 and P-5 for more information

DOWNLOAD AVAILABLE CAD MODELS AT: WWW.HUBCITYINC.COM

Certified prints are available upon request

CALL: (605) 225-0360 • FAX: (605) 225-0567

Hub City ModuLine™ Spherical Roller Bearing Units

Type E Dimensions - Model KPBE

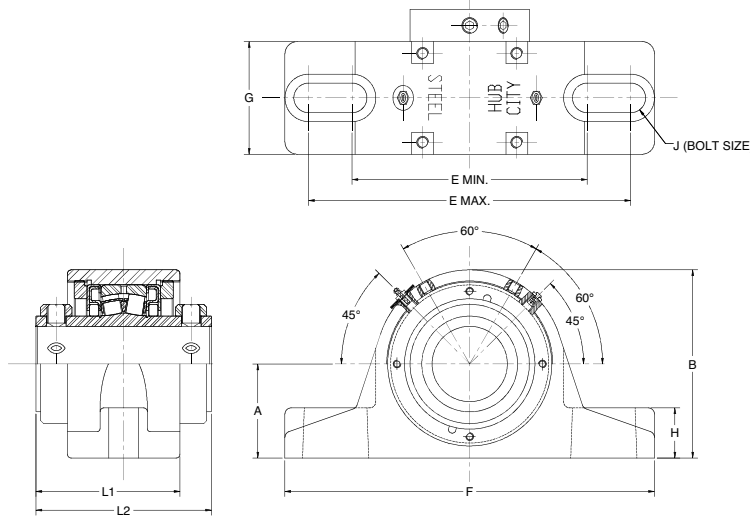

Note: Dimensions $\frac{\text{in}}{\text{mm}}$
Shown are:

Note: Shaft sizes 2-15/16" and up have a dual locking collar, L2 dimension applies.

Bearing bore size tolerances are as follows:
1.4375 to 2.500 +.001/-0
2.6875 to 4.9375 +.0015/-0

Two Bolt Pillow Blocks

DESCRIPTION	BORE SIZE	SET-SCREW	A	B	E (MIN)	E (MAX)	F	G	H	J (BOLT SIZE)	L1	L2								
KPBE1-7/16*	1.4375	3/8-24 UNF	1.875	3.75	4.69	6.00	7.36	2.24	1.00	1/2	2.87									
KPBE1-1/2*	1.5000		[47.63]	[95.3]	[119.0]	[152.4]	[187.0]	[57.0]	[25.4]		[73.0]									
KPBE1-11/16*	1.6875	3/8-24 UNF	2.125	4.13	5.69	6.50	7.87	2.24	1.00	1/2	3.00									
KPBE1-3/4*	1.7500		[53.98]	[105.0]	[144.5]	[165.1]	[200.0]	[57.0]	[25.4]		[76.1]									
KPBE1-15/16*	1.9375	3/8-24 UNF	2.250	4.50	6.00	7.25	8.86	2.24	1.22	5/8	3.00									
KPBE2*	2.0000		[57.15]	[114.3]	[152.4]	[184.2]	[225.0]	[57.0]	[31.0]		[76.1]									
KPBE2-3/16*	2.1875	3/8-24 UNF	2.500	5.00	6.50	8.00	9.63	2.36	1.22	5/8	3.18									
KPBE2-1/4*	2.2500		[63.50]	[127.0]	[165.1]	[203.2]	[244.5]	[60.0]	[31.0]		[80.8]									
KPBE2-7/16*	2.4375	1/2-20 UNF	2.750	5.50	6.88	8.74	10.24	2.80	1.38	5/8	3.52									
KPBE2-1/2*	2.5000		[69.85]	[139.7]	[174.8]	[222.0]	[260.0]	[71.0]	[35.0]		[89.5]									
KPBE2-11/16*	2.6875	1/2-20 UNF	3.125	6.25	7.88	9.76	11.75	2.92	1.38	3/4	3.84									
KPBE2-3/4*	2.7500										[79.38]	[158.8]	[200.2]	[248.0]	[298.5]	[74.2]	[35.0]	[97.4]		
KPBE2-15/16*	2.9375																			4.75
KPBE3*	3.0000																			[120.7]
KPBE3-7/16*	3.4375	1/2-20 UNF	3.75	7.50	9.38	11.50	13.74	3.50	1.85	7/8		5.19								
KPBE3-1/2*	3.5000		[95.3]	[190.5]	[238.3]	[292.1]	[349.0]	[88.9]	[47.0]		[131.7]									
KPBE3-15/16*	3.9375	5/8-18 UNF	4.13	8.30	10.04	12.63	14.50	3.74	2.00	1		5.94								
KPBE4*	4.0000		[104.8]	[210.8]	[255.0]	[320.8]	[368.3]	[95.0]	[50.8]		[150.8]									

* Specify Seal Design and Material

LT: Labyrinth Teflon (std)

DN: Double Lip Nitrile

TN: Triple Lip Nitrile

See pages P-3 and P-5 for more information

DOWNLOAD AVAILABLE CAD MODELS AT: WWW.HUBCITYINC.COM

Certified prints are available upon request

EMAIL: hubsales@regalbeloit.com • www.hubcityinc.com



Hub City ModuLine™ Spherical Roller Bearing Units

Type E Dimensions - Model KPBE

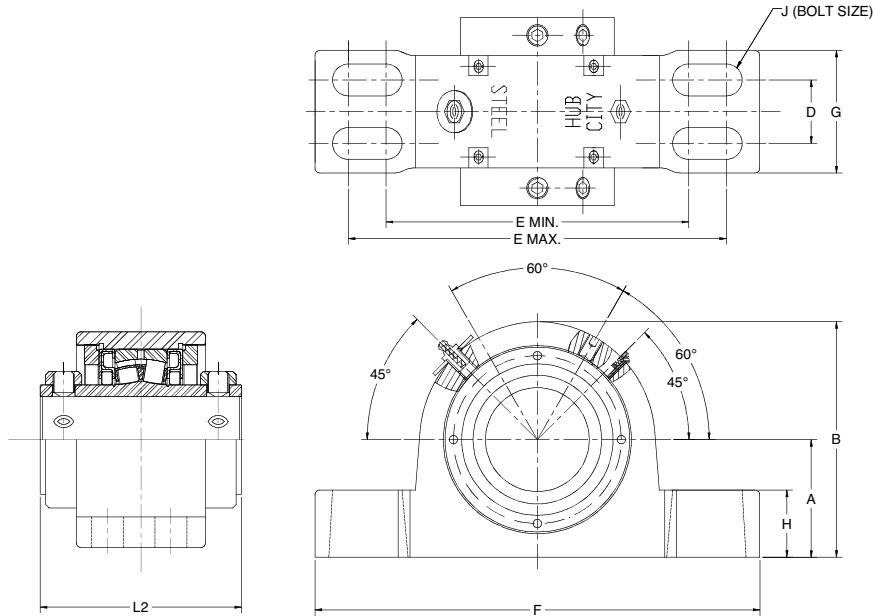

Note: Dimensions $\frac{\text{in}}$
Shown are: $\frac{\text{mm}}$

Bearing bore size tolerances are as follows:

1.4375 to 2.500 +.001/-0
2.6875 to 4.9375 +.0015/-0

Four Bolt Pillow Blocks

DESCRIPTION	BORE SIZE	SET-SCREW	A	B	D	E (MIN)	E (MAX)	F	G	H	J (BOLT SIZE)	L2
KPBE4-7/16*	4.4375	5/8-18 UNF	4.750 [120.65]	9.70 [246.4]	2.50 [63.5]	11.83 [300.4]	14.50 [368.3]	16.13 [409.6]	4.72 [120.0]	2.00 [50.8]	3/4	6.13 [155.6]
KPBE4-15/16*	4.9375	5/8-18 UNF	5.500 [139.70]	10.98 [279.0]	2.76 [70.0]	15.13 [384.3]	15.88 [403.4]	17.50 [444.5]	5.12 [130.0]	2.00 [50.8]	7/8	6.63 [168.3]

* Specify Seal Design and Material

LT: Labyrinth Teflon (std)

DN: Double Lip Nitrile

TN: Triple Lip Nitrile

See pages P-3 and P-5 for more information

DOWNLOAD AVAILABLE CAD MODELS AT: WWW.HUBCITYINC.COM

Certified prints are available upon request

CALL: (605) 225-0360 • FAX: (605) 225-0567

Hub City ModuLine™ Spherical Roller Bearing Units

Type E Dimensions - Model KFBE

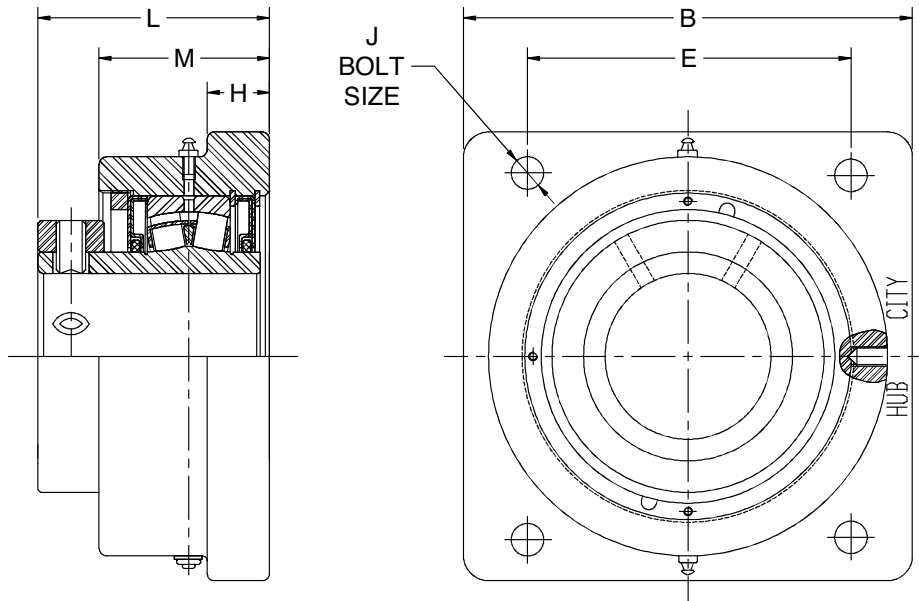

Four Bolt Flange Blocks

Note: Dimensions $\frac{\text{in}}{\text{mm}}$
Shown are:

DESCRIPTION	BORE SIZE	SET-SCREW	B	E	H	J (BOLT SIZE)	L	M
KFBE1-7/16*	1.4375	3/8-24 UNF	4.63	3.50	0.63	1/2	2.87	2.13
KFBE1-1/2*	1.5000		[117.5]	[88.9]	[16.0]		[73.0]	[54.0]
KFBE1-11/16*	1.6875	3/8-24 UNF	5.38	4.13	0.63	1/2	2.99	2.20
KFBE1-3/4*	1.7500		[136.7]	[104.8]	[16.0]		[76.0]	[56.0]
KFBE1-15/16*	1.9375	3/8-24 UNF	5.62	4.38	0.63	1/2	2.99	2.20
KFBE2*	2.0000		[142.7]	[111.1]	[16.0]		[76.0]	[56.0]
KFBE2-3/16*	2.1875	3/8-24 UNF	6.26	4.88	0.79	5/8	3.24	2.44
KFBE2-1/4*	2.2500		[159.0]	[123.8]	[20.0]		[82.4]	[62.0]
KFBE2-7/16*	2.4375	1/2-20 UNF	6.88	5.38	0.87	5/8	3.49	2.72
KFBE2-1/2*	2.5000		[174.8]	[136.5]	[22.0]		[88.7]	[69.0]
KFBE2-11/16*	2.6875	1/2-20 UNF	7.76	6.00	0.87	3/4	3.74	2.72
KFBE2-3/4*	2.7500							
KFBE2-15/16*	2.9375							
KFBE3*	3.0000							
KFBE3-7/16*	3.4375	1/2-20 UNF	9.25	7.00	0.94	3/4	4.15	3.11
KFBE3-1/2*	3.5000							
KFBE3-15/16*	3.9375	5/8-18 UNF	10.24	7.75	1.10	7.8	4.71	3.50
KFBE4*	4.0000							

* Specify Seal Design and Material

LT: Labyrinth Teflon (std)

DN: Double Lip Nitrile

TN: Triple Lip Nitrile

See pages P-3 and P-5 for more information

DOWNLOAD AVAILABLE CAD MODELS AT: WWW.HUBCITYINC.COM

Certified prints are available upon request

EMAIL: hubsales@regalbeloit.com • www.hubcityinc.com

Hub City ModuLine™ Spherical Roller Bearing Units

Moduline™ Accessories - Closed Covers

Features

- Heavy duty metal construction
- Treated for corrosion resistance
- Can be filled with grease for an additional barrier of protection
- Includes mounting hardware for easy bolt-on attachment
- Designed for places where heavy contamination is a threat
- Effective in high moisture environments



Closed Cover Dimensions

PART NUMBER	Shaft Size (in)	LENGTH from Bearing Centerline	Max Shaft Length (From Centerline)	Cover Body Diameter
1029-20401	1-7/16	2.8	2.5	2.75
	1-1/2			
1029-20402	1-11/16	2.8	2.5	2.95
	1-3/4			
1029-20403	1-15/16	2.9	2.7	3.15
	2			
1029-20404	2-3/16	3.2	2.9	3.55
	2-1/4			
1029-20405	2-7/16	3.7	3.4	4.20
	2-1/2			
1029-20406	2-11/16	3.7	3.4	4.60
	2-3/4			
	2-15/16			
	3			
1029-20407	3-7/16	4.2	3.9	5.50
	3-1/2			
1029-20408	3-15/16	4.5	4.2	6.32
	4			
1029-20409	4-7/16	5.3	5.0	7.10
1029-20410	4-15/16	5.3	5.0	8.25

DOWNLOAD AVAILABLE CAD MODELS AT: WWW.HUBCITYINC.COM

Certified prints are available upon request

CALL: (605) 225-0360 • FAX: (605) 225-0567

Hub City ModuLine™ Spherical Roller Bearing Units

Moduline™ Accessories - Open Covers



Features

- Heavy duty metal construction
- Treated for corrosion resistance
- Can be filled with grease for an additional barrier of protection
- Includes mounting hardware for easy bolt-on attachment
- Designed for places where heavy contamination is a threat
- Effective in high moisture environments
- Equipped with Teflon Labyrinth seal for superior protection at all speeds and high temperatures

Closed Cover Dimensions

PART NUMBER	Shaft Size (in)	LENGTH from Bearing Centerline	Cover Body Diameter
1029-20411	1-7/16	2.3	2.75
1029-20412	1-1/2	2.3	2.75
1029-20413	1-11/16	2.5	2.95
1029-20414	1-3/4	2.5	2.95
1029-20415	1-15/16	2.5	3.15
1029-20416	2	2.5	3.15
1029-20417	2-3/16	2.5	3.55
1029-20418	2-1/4	2.5	3.55
1029-20419	2-7/16	2.7	4.20
1029-20420	2-1/2	2.7	4.20
1029-20421	2-11/16	3.0	4.60
1029-20422	2-3/4	3.0	4.60
1029-20423	2-15/16	3.0	4.60
1029-20424	3	3.0	4.60
1029-20425	3-7/16	3.3	5.50
1029-20426	3-1/2	3.3	5.50
1029-20427	3-15/16	3.5	6.32
1029-20428	4	3.5	6.32
1029-20429	4-7/16	4.3	7.10
1029-20430	4-15/16	4.3	8.25

DOWNLOAD AVAILABLE CAD MODELS AT: WWW.HUBCITYINC.COM

Certified prints are available upon request

EMAIL: hubsales@regalbeloit.com • www.hubcityinc.com

Hub City ModuLine™ Spherical Roller Bearing Units

Modified and Custom Designs

If you have looked through this catalog and do not see exactly what you need, Hub City has the capability and engineering expertise to design and produce modified or custom mounted bearings.

Capabilities range as follows:

- Special sealing requirements or materials
- Special lubricants
- Housing modifications
- Special paint or housing coatings
- Modifications for specific or unique application requirements

Consult the factory or your Hub City representative with your specifications.

Hub City HubFlex™ Coupling

HubFlex™ Features and Advantages	Q-2
Green Technology and Sustainability	Q-3
Coupling Ordering Nomenclature	Q-4
Inserts	Q-5
Covers.....	Q-6
Coupling Selection	Q-7
Dimensions/Ratings	Q-8-9
Bore Sizes and Tolerances	Q-10-11
Torque Ratings.....	Q-12-13
Misalignment Tolerances	Q-14
Service Factors.....	Q-15-17
Compatibility Chart	Q-18
Safety Guidelines	Q-19
Quick Selection Guide	Q-20

Hub City HubFlex™ Coupling

Introduction

The HubFlex™ Coupling made in the USA, is one of the **easiest** and least expensive couplings to install, maintain, and repair! A complete coupling consists of 2 hubs, available in carbon or stainless steel, a urethane split insert (choose from 5 types), and a cover – either a slide over cover held in by a snap ring or a horizontally split cover for extreme torque applications.

Once you have correctly selected and properly installed a HubFlex™ coupling, the split insert is all you should have to replace. Replacement of the insert is **easy** and your equipment can be back up and running in minutes! Once the hubs are installed, they never need to be moved again. Remove only the cover, replace the insert, re-install the cover, and you are ready to **GO!**

The HubFlex™ advantages:

- Fast and **EASY** insert replacement!
 - Low maintenance!
 - No lubrication required!
- Fast and **easy** insert replacement.
 - Low maintenance.
 - Minimal downtime.
 - No lubrication required.
 - Urethane inserts available from **Standard Duty** to **eXtreme Duty**, **High Temperature**, and **Food Grade**.
 - Can be installed vertically.
 - Compact.
- The teeth on the hubs do not touch or overlap thus if the insert fails, you do not have metal to metal contact that will potentially destroy the hubs.
 - Reversing applications.
 - No realignment required after insert replacement.
 - We use PM material – a **Green Technology**.



DOWNLOAD AVAILABLE CAD MODELS AT: WWW.HUBCITYINC.COM

Certified prints are available upon request

CALL: (605) 225-0360 • FAX: (605) 225-0567

Hub City HubFlex™ Coupling

Green Technology & Sustainability

A RECOGNIZED GREEN TECHNOLOGY

HubFlex™ Couplings are made from Powdered Metal (PM), which uses less energy in the manufacturing process, using “green” technology.



A recognized green
technology

The Sustainability Role of Powder Metallurgy

For many years, powder metallurgy has been delivering sustainable value as an industry. The following explanation compares and contrasts PM’s sustainable value with other metal forming processes.

Addressing manufacturing processes, PM’s sustainable value is primarily derived from its net-shape capabilities and its very high material-utilization factor, which minimizes all energy inputs. In general, any metal component can be manufactured by any of several manufacturing technologies. A simple gear can be produced by machining a cylindrical piece of solid bar stock, forging a steel blank in forging dies, in some cases stamping it from sheet or roll stock, possibly casting it and machining features, or in the case of PM compacting powder in tooling dies that result in the product’s final shape. The trick to evaluating the sustainability of a product’s manufacture will be found in comparing the process steps, resources, and economic costs that go into the manufacture of that product.

The net-shape capability of PM is the primary advantage in the process. When evaluating a component, such as a gear shape, you can quickly realize that there is no waste in the shaping of the component. Production of the gear by chip-generating machining would result in perhaps 40% of the material being machined away and discarded. While the machining waste can be recycled, it is extraneous to the final component and is a net loss to the material and energy eco-efficiency of the final component.

It is estimated that 85% of all PM powders are produced from recycled material. Most metals can be repetitively recycled in collectable quantities. The predominant metal powder used, iron/steel, nearly a half million tons per year, is nearly always produced via atomization of electrically melted steel scrap. Particle-size distribution in a given sample or lot of powder is controlled by sieving operations, and if the particle size needs to be adjusted, the powders can be milled to avoid waste of oversized particles. PM fabrication facilities generally realize operational-scrap losses of 3 percent or less.

The net-shape nature of PM similarly influences the energy demand per component. All manufacturing processes require the use of thermal, chemical, or mechanical energy to achieve product form. Some processes require several heating and re-heating steps to achieve final form. The only time metal for powders is melted is in the atomization step; all other thermal operations are undertaken below melting temperature, conserving energy while achieving the final shape and developing the necessary material properties/mechanical performance. In addition, there is little if any finishing to final product specifications necessary, further conserving the energy necessary to achieve final product characteristics.



Sustainable Employment

U.S. manufacturing contributes more economic activity than any other sector of the economy, with each dollar of manufactured goods generating \$1.37 of additional economic activity. According to statistics developed by the Manufacturing Institute, manufacturing jobs pay 9% more than all employees in the U.S. economy. The 2009 U.S. Bureau of Labor Statistics placed the average value of U.S. manufacturing jobs at \$32/hour. PM average hourly wage is estimated at \$35/hour. PM manufacturing contributes significantly to local economies. In North Central Pennsylvania there is a high concentration of PM manufacturers, which constitute a significant element of the local economy in this rural area. Many companies and their employees are active in supporting community organizations.

DOWNLOAD AVAILABLE CAD MODELS AT: WWW.HUBCITYINC.COM

Certified prints are available upon request

EMAIL: hubsales@regalbeloit.com • www.hubcityinc.com



Hub City HubFlex™ Coupling

Coupling Ordering Nomenclature

Hubs (2 required)

Information required: Coupling Size, Bore Sizes (driver and driven), and material (carbon steel or stainless steel)

Example: Coupling Size: HF20
Bore Size: 5/8" Carbon Steel

HF20 CS 010 H

Coupling Series	Available Soon:
HF10	HF50
HF20	HF60
HF30	HF70
HF40	HF80
	HF90
	HF100
	HF110
	HF120

Material
CS = Carbon Steel
SS = Stainless Steel

Size*	
PB = Pilot Bore	107 = 1-7/16"
008 = 1/2"	108 = 1-1/2"
010 = 5/8"	110 = 1-5/8"
012 = 3/4"	112 = 1-3/4"
014 = 7/8"	114 = 1-7/8"
015 = 15/16"	115 = 1-15/16"
100 = 1"	200 = 2"
102 = 1-1/8"	202 = 2-1/8"
103 = 1-3/16"	203 = 2-3/16"
104 = 1-1/4"	204 = 2-1/4"
106 = 1-3/8"	206 = 2-3/8"
	207 = 2-7/16"

Description
H = Hub



*Metric, Shrink Fit, Spline Bores available on request.

Insert

Information required: Coupling Size, Insert Type: Standard (Orange), Medium (Green), Extreme (Black), Hi-Temp (Grey), or Food Grade (White)

Example: Coupling Size: HF20
Insert type: Standard (Orange)

HF20 SD -INS

Coupling Series	Available Soon:
HF10	HF50
HF20	HF60
HF30	HF70
HF40	HF80
	HF90
	HF100
	HF110
	HF120

Material
SD = Standard Duty (Orange)
MD = Medium (Green)
XD = Extreme (Black)
HT = Hi-Temp (Grey)
FG = Food Grade (White)

Description
-INS = Insert



Cover

Information required: Coupling Size, Standard (specify Carbon Steel or Stainless Steel), or Extreme Duty (Horizontal Split)

Example: Coupling Size: HF20
Cover: Standard - Carbon Steel

HF20 SD -CVR

Coupling Series	Available Soon:
HF10	HF50
HF20	HF60
HF30	HF70
HF40	HF80
	HF90
	HF100
	HF110
	HF120

Material
SD = Carbon Steel
XH = Extreme
SS = Stainless Steel

Description
-CVR = Cover



DOWNLOAD AVAILABLE CAD MODELS AT: WWW.HUBCITYINC.COM

Certified prints are available upon request

CALL: (605) 225-0360 • FAX: (605) 225-0567

Hub City HubFlex™ Coupling Inserts

HubFlex™ Couplings utilize urethane inserts which are resistant to oils, corrosion, most chemicals, and have excellent wear properties. Inserts are available in five materials for various applications.



HubFlex™ Orange INSERT (Standard)

- Operational temperature range of -60°F to 212°F (-50°C to 100°C).
- The regular Orange insert is made from a moderately soft urethane compound.
- Applications – vibration dampening, cushioning of shock loads, reversing, or quick starting and stopping of high inertial loads.



HubFlex™ GREEN INSERT (Medium Torque)

- Operational temperature range of -60°F to 212°F (-50°C to 100°C).
- The green insert has a higher durometer urethane resulting in a more rigid insert designed for higher torque applications than the regular insert.
- Applications - moderate to high torque. Excellent replacements for gear or grid style couplings.



HubFlex™ BLACK INSERT (Extreme - Highest Torque)

- Operational temperature range of -60°F to 212°F (-50°C to 100°C).
- The black insert provides our highest torque ratings.
- Applications - excellent replacements for gear and grid style couplings.



HubFlex™ GREY INSERT (High Temperature)

- Operational temperature range up to 350°F (177°C)
- The grey insert is made for applications where heat is a concern.
- Applications – same capabilities as our green insert.



HubFlex™ WHITE INSERT (Food Grade)

- Operational temperature range of -60°F to 212°F (-50°C to 100°C).
- The food grade white insert is FDA approved for use with both wet and dry foods.
- Applications – similar capabilities as the Orange insert.

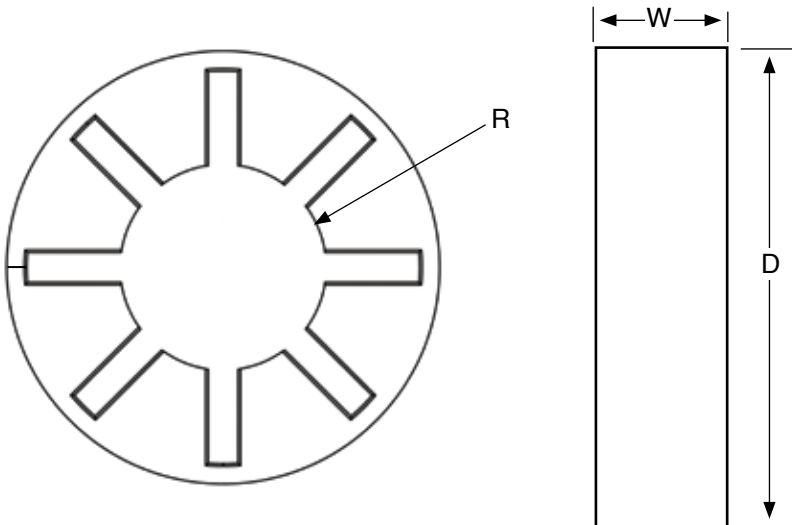

HubFlex™ Insert Dimensions (in.)

Coupling Series	R	D	W	Wt. (lbs)
HF10	1.23	2.23	0.63	0.05
HF20	1.66	2.86	0.85	0.10
HF30	2.16	3.80	1.23	0.30
HF40	2.41	5.05	1.64	0.80
Additional Sizes Available Soon:				
HF50	3.05	6.44	2.02	1.45
HF60	3.90	7.37	2.35	2
HF70	4.13	8.20	2.32	3
HF80	4.34	9.98	2.63	5
HF90	6.19	11.30	2.96	6
HF100	7.60	13.61	3.24	9
HF110	9.15	15.93	3.67	13
HF120	11.25	19.04	5.43	31

DOWNLOAD AVAILABLE CAD MODELS AT: WWW.HUBCITYINC.COM

Certified prints are available upon request

EMAIL: hubsales@regalbeloit.com • www.hubcityinc.com



Hub City HubFlex™ Coupling Covers

HubFlex™ Standard Cover

Designed for applications where low torque and/or high speed is present.

HubFlex™ Standard Cover
Dimensions (in.)

Cover Part # (XX=Material)	Maximum RPM*	D	W
HF10XX-CVR	4000	2.49	0.95
HF20XX-CVR	4000	3.16	1.35
HF30XX-CVR	4000	4.21	1.95
HF40XX-CVR	4000	5.48	2.38
Additional Sizes Available Soon:			
HF50XX-CVR	4000	7.00	2.96
HF60XX-CVR	4000	8.00	3.27
HF70XX-CVR	3800	8.88	3.50
HF80XX-CVR	3400	10.77	4.05

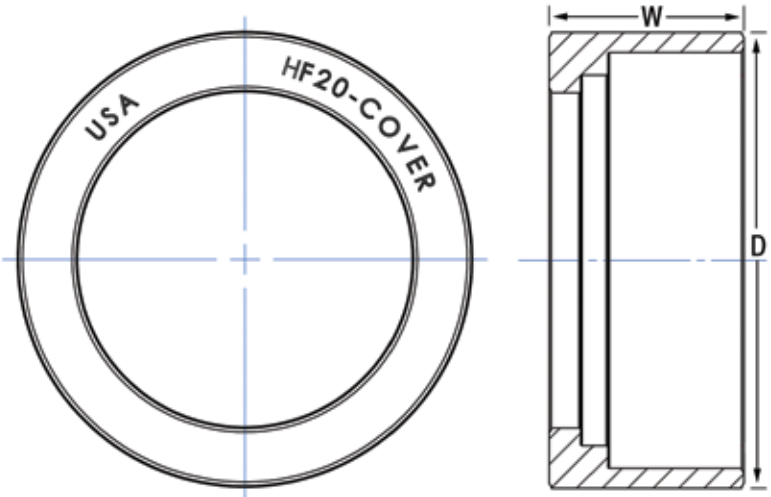

* For applications over 4000 RPM, consult factory

HubFlex™ Extreme Duty Cover

Designed for all applications including high or low torque and speed ratings while eliminating axial loading.

HubFlex™ Extreme
Duty Cover Dimensions (in.)

Cover Part #	Maximum RPM*	W	D	Bolt Size
HF10XH-CVR	4000	1.93	3.99	(4) 1/4 nc x 7/8
HF20XH-CVR	4000	2.61	5.34	(4) 3/8 nc x 1-1/4
HF30XH-CVR	4000	3.02	7.28	(4) 1/2 nc x 2
HF40XH-CVR	4000	5.96	7.76	(4) 1/2 nc x 2-1/4
Additional Sizes Available Soon:				
HF50XH-CVR	4000	6.17	8.52	(4) 5/8 nc x 2-1/2
HF60XH-CVR	3800	9.24	14.35	(4) 3/4 nc x 3-1/2

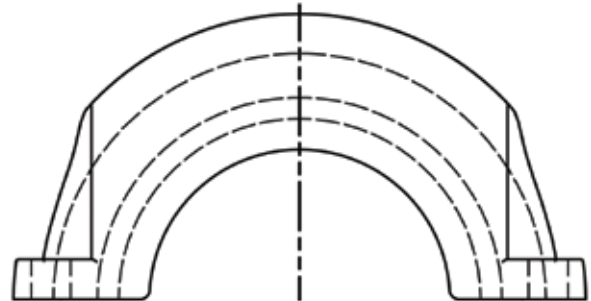
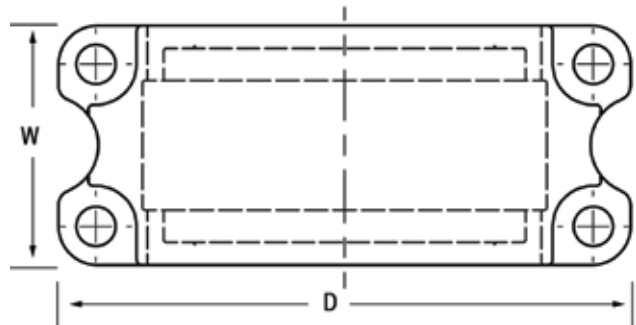

* For applications over 4000 RPM, consult factory
Stainless steel hardware provided with all Extreme Duty covers

DOWNLOAD AVAILABLE CAD MODELS AT: WWW.HUBCITYINC.COM

Certified prints are available upon request

CALL: (605) 225-0360 • FAX: (605) 225-0567

Hub City HubFlex™ Coupling

Coupling Selection

HubFlex™ Coupling Selection

Information required before a coupling can be selected:

- HP and RPM or torque of driver
- Shaft sizes of driver and driven equipment
- Corresponding keyways
- Application description to determine service factor
- Environmental conditions

Step 1: Determine the Nominal Torque (T) of your application:

$$\text{in/lbs} = T = \frac{(63025 \times \text{HP})}{\text{RPM}}$$

HP = Drive Horsepower

RPM = Drive Shaft Revolutions Per Minute

Step 2: Refer to pages 15-17 to determine Application Service Factor

Step 3: Calculate the Design Torque of your application.

Design Torque = Nominal Torque (T) x Application Service Factor

Example:

Driver: 5HP, 1800RPM electric motor

Driven: belt conveyor (refer to pages 15-17)

$$\text{in/lbs} = T = \frac{(63025 \times 5\text{HP})}{1800}$$

Nominal Torque (T) = 175 in/lbs

Design Torque = 175 (Nominal Torque) x 1.75 (Application Service Factor from pages 15-17)

Design Torque = 306.25 in/lbs Torque

Step 4: Refer to page 8 to select correct coupling size - ie. HF10

Step 5: Confirm that the shaft size of the driver and driven shafts are equal to or less than the maximum bore size (refer to coupling dimensional pages)

Step 6: Confirm environmental conditions to determine correct cover, hubs, and insert material (stainless steel or carbon steel hubs and cover, food grade, high temp or standard insert)

Hub City HubFlex™ Coupling

Dimensions/Ratings

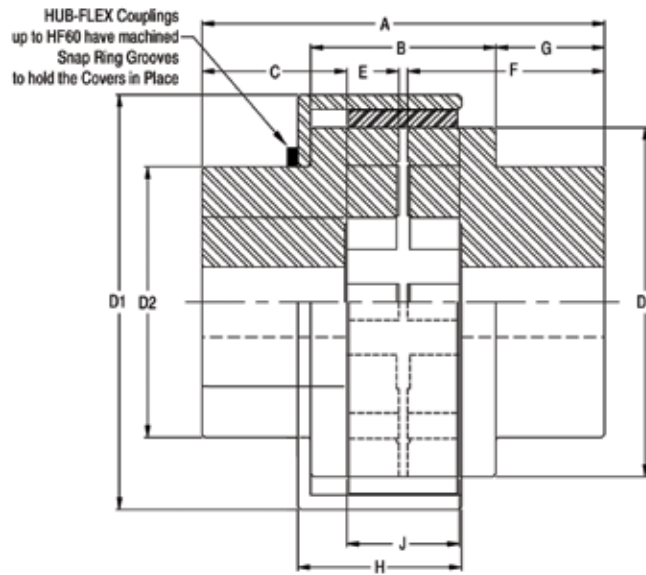

HubFlex™ Standard Coupling Dimensions (in.)

Coupling Series	Pilot Bore Diameter	Maximum Bore Size	Maximum RPM*	Maximum Torque (in-lbs)**	A	B	D1	D2	D3	C	E _{MIN}	E _{MAX}	F	G	H	J	WT** (lbs)	
HF10	1/2	1-1/4	4000	792	2.80	1.03	2.49	2.00	2.07	1.08	0.062	0.092	1.37	0.88	0.95	0.66	4	
HF20	1/2	1-5/8	4000	1965	3.54	1.28	3.16	2.31	2.55	1.34	0.036	0.110	1.75	1.14	1.35	0.88	5	
HF30	3/4	2-1/8	4000	6183	4.86	2.00	4.21	3.19	3.37	1.81	0.080	0.205	2.39	1.42	1.95	1.21	11	
HF40	3/4	2-3/8	4000	13680	5.96	2.42	5.48	3.52	4.49	2.16	0.035	0.208	2.96	1.78	2.38	1.66	15	
Additional Sizes Available Soon:																		
HF50	15/16	3	4000	27468	7.07	3.48	7.00	4.25	5.92	2.46	0.140	0.290	3.40	1.76	2.96	2.19	37	
HF60	1	3-7/8	4000	46510	7.69	3.67	8.00	5.50	6.75	2.67	0.188	0.208	3.75	2.00	3.27	2.45	57	
HF70	1-1/2	4-1/8	3800	60430	8.51	3.96	8.88	5.79	7.48	3.10	0.100	0.230	4.21	2.33	3.50	2.49	71	
HF80	1-7/8	4-1/2	3400	114227	10.13	4.67	10.77	7.00	9.25	3.75	0.125	0.250	5.00	2.75	4.05	2.75	126	

* For applications over 4000 RPM, consult factory
 ** All weights shown are approximate for a complete standard coupling assembly.
 *** Maximum torque values (in-lbs) are based on use with green insert. Refer to page 12 for complete torque ratings.

HubFlex™ Insert Maximum Torque Ratings (in-lbs)

Coupling Series	Orange	GREEN	BLACK	GREY	WHITE
HF10	365	792	-	792	365
HF20	1003	1965	-	1965	1003
HF30	3279	6183	-	6183	3279
HF40	6903	13680	-	13680	6903
Estimated Torque Ratings for Additional Sizes Available Soon:					
HF50	13852	27468	-	27468	13852
HF60	24282	46510	-	46510	24282
HF70	30438	60430	-	60430	30438
HF80	59430	114227	-	114227	59430

It is not recommended to use the Black insert with the Standard Cover. In high torque applications we recommend the use of the Extreme Duty Cover.



Hub City HubFlex™ Coupling

Dimensions/Ratings

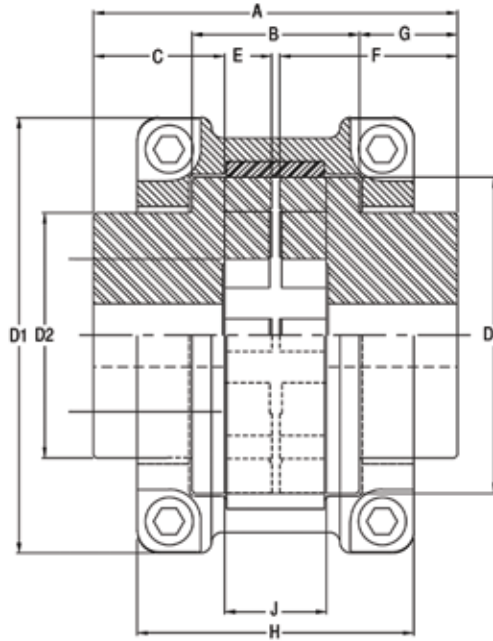

HubFlex™ Extreme Duty Coupling Dimensions (in.)

Coupling Series	Pilot Bore Diameter	Maximum Bore Size - Square Key	Maximum RPM*	Maximum Torque (in-lbs)***	A	B	D1	D2	D3	C	E _{MIN}	E _{MAX}	F	G	H	J	WT** (lbs)
HF20	1/2	1-5/8	4000	3789	3.54	1.28	3.99	2.31	2.55	1.34	0.036	.220	1.75	1.14	1.93	0.88	5
HF30	3/4	2-1/8	4000	11914	4.86	2.00	5.34	3.19	3.37	1.81	0.080	0.160	2.39	1.42	2.61	1.21	12
HF40	3/4	2-3/8	4000	25870	5.96	2.42	7.28	3.52	4.49	2.16	0.035	0.160	2.96	1.78	3.02	1.66	17
Additional Sizes Available Soon:																	
HF50	15/16	3	4000	52408	7.07	3.48	7.76	4.25	5.92	2.46	0.140	0.370	3.40	1.76	5.96	2.19	40
HF60	1	3-7/8	4000	87110	7.69	3.67	8.52	5.50	6.75	2.67	0.188	0.368	3.75	2.00	6.17	2.45	59
HF70	1-1/2	4-1/8	3800	116432	8.51	3.96	10.29	5.79	7.48	3.10	0.100	0.318	4.21	2.33	6.54	2.49	81
* For applications over 4000 RPM, consult factory																	
** All weights shown are approximate for a complete standard coupling assembly.																	
*** Maximum torque values (in-lbs) are based on use with black insert. Refer to page 13 for complete torque ratings.																	

HubFlex™ Insert Maximum Torque Ratings (in-lbs)

Coupling Series	ORANGE	GREEN	BLACK	GREY	WHITE
HF20	1254	2457	3789	2457	1254
HF30	4099	7730	11914	7730	4099
HF40	8630	17099	25870	17099	8630
Estimated Torque Ratings for Additional Sizes Available Soon:					
HF50	17315	34336	52408	34336	17315
HF60	30353	58137	87110	58137	30353
HF70	38048	75538	116432	75538	38048

DOWNLOAD AVAILABLE CAD MODELS AT: WWW.HUBCITYINC.COM

Certified prints are available upon request

EMAIL: hubsales@regalbeloit.com • www.hubcityinc.com



Hub City HubFlex™ Coupling

Bore - Keyway Sizes and Tolerances

HF10

PART NO. XX=MATL	BORE DIA.	KEYWAY	W	H	SET SCREW [2@120°]	STAMP
HF10XX-PBH	1/2"	NONE	NONE	NONE	NONE	NONE
HF10XX008H	1/2"	1/8 X 1/16	.1250/.1280		5/16"-18	1/2
HF10XX010H	.6255/.6265	3/16 X 3/32	.1875/.1905	.7094/.7244	5/16"-18	5/8
HF10XX012H	.7505/.7515	3/16 X 3/32	.1875/.1905	.8368/.8518	5/16"-18	3/4
HF10XX014H	.8755/.8765	3/16 X 3/32	.1875/.1905	.9636/.9786	5/16"-18	7/8
HF10XX100H	1.0005/1.0015	1/4 X 1/8	.2500/.2530	1.1142/1.1292	5/16"-18	1
HF10XX102H	1.1255/1.1265	1/4 X 1/8	.2500/.2530	1.2409/1.2559	5/16"-18	1-1/8
HF10XX103H	1.1880/1.1890	1/4 X 1/8	.2500/.2530	1.3042/1.3192	5/16"-18	1-3/16
HF10XX104H	1.2505/1.2515	1/4 X 1/8	.2500/.2530	1.3674/1.3824	5/16"-18	1-1/4

HF20

PART NO. XX=MATL	BORE DIA.	KEYWAY	W	H	SET SCREW [2@120°]	STAMP
HF20XX-PBH	1/2"	NONE	NONE	NONE	NONE	NONE
HF20XX010H	.6255/.6265	3/16 X 3/32	.1875/.1905	.7094/.7244	5/16"-18	5/8
HF20XX012H	.7505/.7515	3/16 X 3/32	.1875/.1905	.8368/.8518	5/16"-18	3/4
HF20XX014H	.8755/.8765	3/16 X 3/32	.1875/.1905	.9636/.9786	5/16"-18	7/8
HF20XX100H	1.0005/1.0015	1/4 X 1/8	.2500/.2530	1.1142/1.1292	5/16"-18	1
HF20XX102H	1.1255/1.1265	1/4 X 1/8	.2500/.2530	1.2409/1.2559	5/16"-18	1-1/8
HF20XX103H	1.1880/1.1890	1/4 X 1/8	.2500/.2530	1.3042/1.3192	5/16"-18	1-3/16
HF20XX104H	1.2505/1.2515	1/4 X 1/8	.2500/.2530	1.3674/1.3824	5/16"-18	1-1/4
HF20XX106H	1.3755/1.3765	5/16 X 5/32	.3125/.3155	1.5183/1.5333	5/16"-18	1-3/8
HF20XX107H	1.4380/1.4390	3/8 X 3/16	.3750/.3780	1.6051/1.6201	5/16"-18	1-7/16
HF20XX108H	1.5005/1.5015	3/8 X 3/16	.3750/.3780	1.6687/1.6837	5/16"-18	1-1/2
HF20XX110H	1.6255/1.6265	3/8 X 3/16	.3750/.3780	1.7956/1.8106	5/16"-18	1-5/8

DOWNLOAD AVAILABLE CAD MODELS AT: WWW.HUBCITYINC.COM

Certified prints are available upon request

CALL: (605) 225-0360 • FAX: (605) 225-0567

Hub City HubFlex™ Coupling

Bore - Keyway Sizes and Tolerances

HF30

PART NO. XX=MATL	BORE DIA.	KEYWAY	W	H	SET SCREW [2@120°]	STAMP
HF30XX-PBH	3/4"	NONE	NONE	NONE	NONE	NONE
HF30XX014H	.8755/.8765	3/16 X 3/32	.1875/.1905	.9636/.9786	5/16"-18	7/8
HF30XX100H	1.0005/1.0015	1/4 X 1/8	.2500/.2530	1.1142/1.1292	5/16"-18	1
HF30XX102H	1.1255/1.1265	1/4 X 1/8	.2500/.2530	1.2409/1.2559	5/16"-18	1-1/8
HF30XX103H	1.1880/1.1890	1/4 X 1/8	.2500/.2530	1.3042/1.3192	5/16"-18	1-3/16
HF30XX104H	1.2505/1.2515	1/4 X 1/8	.2500/.2530	1.3674/1.3824	5/16"-18	1-1/4
HF30XX106H	1.3755/1.3765	5/16 X 5/32	.3125/.3155	1.5183/1.5333	5/16"-18	1-3/8
HF30XX107H	1.4380/1.4390	3/8 X 3/16	.3750/.3780	1.6051/1.6201	5/16"-18	1-7/16
HF30XX108H	1.5005/1.5015	3/8 X 3/16	.3750/.3780	1.6687/1.6837	5/16"-18	1-1/2
HF30XX110H	1.6255/1.6265	3/8 X 3/16	.3750/.3780	1.7956/1.8106	5/16"-18	1-5/8
HF30XX112H	1.7505/1.7515	3/8 X 3/16	.3750/.3780	1.9225/1.9425	5/16"-18	1-3/4
HF30XX114H	1.8755/1.8775	1/2 X 1/4	.5000/.5050	2.0965/2.1165	3/8"-16	1-7/8
HF30XX115H	1.9380/1.9400	1/2 X 1/4	.5000/.5050	2.1605/2.1805	3/8"-16	1-15/16
HF30XX200H	2.0005/2.0025	1/2 X 1/4	.5000/.5050	2.2235/2.2435	3/8"-16	2
HF30XX202H	2.1255/2.1275	1/2 X 1/4	.5000/.5050	2.3505/2.3705	3/8"-16	2-1/8

HF40

PART NO. XX=MATL	BORE DIA.	KEYWAY	W	H	SET SCREW [2@120°]	STAMP
HF40XX-PBH	3/4"	NONE	NONE	NONE	NONE	NONE
HF40XX014H	.8755/.8765	3/16 X 3/32	.1875/.1905	.9636/.9786	5/16"-18	7/8
HF40XX100H	1.0005/1.0015	1/4 X 1/8	.2500/.2530	1.1142/1.1292	5/16"-18	1
HF40XX102H	1.1255/1.1265	1/4 X 1/8	.2500/.2530	1.2409/1.2559	5/16"-18	1-1/8
HF40XX103H	1.1880/1.1890	1/4 X 1/8	.2500/.2530	1.3042/1.3192	5/16"-18	1-3/16
HF40XX104H	1.2505/1.2515	1/4 X 1/8	.2500/.2530	1.3674/1.3824	5/16"-18	1-1/4
HF40XX106H	1.3755/1.3765	5/16 X 5/32	.3125/.3155	1.5183/1.5333	5/16"-18	1-3/8
HF40XX107H	1.4380/1.4390	3/8 X 3/16	.3750/.3780	1.6051/1.6201	5/16"-18	1-7/16
HF40XX108H	1.5005/1.5015	3/8 X 3/16	.3750/.3780	1.6687/1.6837	5/16"-18	1-1/2
HF40XX110H	1.6255/1.6265	3/8 X 3/16	.3750/.3780	1.7956/1.8106	5/16"-18	1-5/8
HF40XX112H	1.7505/1.7515	3/8 X 3/16	.3750/.3780	1.9225/1.9425	5/16"-18	1-3/4
HF40XX114H	1.8755/1.8775	1/2 X 1/4	.5000/.5050	2.0965/2.1165	3/8"-16	1-7/8
HF40XX115H	1.9380/1.9400	1/2 X 1/4	.5000/.5050	2.1605/2.1805	3/8"-16	1-15/16
HF40XX200H	2.0005/2.0025	1/2 X 1/4	.5000/.5050	2.2235/2.2435	3/8"-16	2
HF40XX202H	2.1255/2.1275	1/2 X 1/4	.5000/.5050	2.3505/2.3705	3/8"-16	2-1/8
HF40XX203H	2.1880/2.1900	1/2 X 1/4	.5000/.5050	2.4145/2.4345	3/8"-16	2-3/16
HF40XX204H	2.2505/2.2525	1/2 X 1/4	.5000/.5050	2.4775/2.4975	3/8"-16	2-1/4
HF40XX206H	2.3755/2.3775	5/8 X 5/16	.6250/.6300	2.6515/2.6715	1/2"-13	2-3/8



Hub City HubFlex™ Coupling

Torque Ratings

Torque Ratings for HubFlex™ Couplings with Standard Cover

Coupling Series	Insert Part #	Insert Color	Continuous Torque (in-lbs)	HP Ratings @ Various RPM (Service Factor = 1)							
				100	300	600	900	1200	1800	2400	3600
HF10	HF10SD-INS	Orange	365	.58	1.74	3.48	5.22	6.96	10.44	13.92	20.88
	HF10MD-INS	Green	792	1.26	3.78	7.56	11.34	15.12	22.68	30.24	45.36
	HF10FG-INS	White	365	.58	1.74	3.48	5.22	6.96	10.44	13.92	20.88
HF20	HF20SD-INS	Orange	1003	1.59	4.77	9.54	14.31	19.08	28.62	38.16	57.24
	HF20MD-INS	Green	1965	3.12	9.36	18.72	28.08	37.44	56.16	74.88	112.32
	HF20HT-INS	Grey	1965	3.12	9.36	18.72	28.08	37.44	56.16	74.88	112.32
	HF20FG-INS	White	1003	1.59	4.77	9.54	14.31	19.08	28.62	38.16	57.24
HF30	HF30SD-INS	Orange	3279	5.20	15.60	31.20	46.80	62.40	93.60	124.80	187.20
	HF30MD-INS	Green	6183	9.81	29.43	58.86	88.29	117.72	176.58	235.44	353.16
	HF30HT-INS	Grey	6183	9.81	29.43	58.86	88.29	117.72	176.58	235.44	353.16
	HF30FG-INS	White	3279	5.20	15.60	31.20	46.80	62.40	93.60	124.80	187.20
HF40	HF40SD-INS	Orange	6903	10.95	32.85	65.70	98.55	131.40	197.10	262.80	394.20
	HF40MD-INS	Green	13680	21.71	65.13	130.26	195.39	260.52	390.78	521.04	781.56
	HF40HT-INS	Grey	13680	21.71	65.13	130.26	195.39	260.52	390.78	521.04	781.56
	HF40FG-INS	White	6903	10.95	32.85	65.70	98.55	131.40	197.10	262.80	394.20
Estimated Torque Ratings for Additional Sizes Available Soon:											
HF50	HF50SD-INS	Orange	13852	21.98	65.94	131.88	197.82	263.76	395.64	527.52	791.28
	HF50MD-INS	Green	27468	43.58	130.74	261.48	392.22	522.96	784.44	1045.92	1568.88
	HF50HT-INS	Grey	27468	43.58	130.74	261.48	392.22	522.96	784.44	1045.92	1568.88
	HF50FG-INS	White	13852	21.98	65.94	131.88	197.82	263.76	395.64	527.52	791.28
HF60	HF60SD-INS	Orange	24282	38.53	115.59	231.88	346.77	462.36	693.54	924.72	1387.08
	HF60MD-INS	Green	46510	73.80	221.40	442.80	664.20	885.60	1328.40	1771.20	2656.80
	HF60HT-INS	Grey	46510	73.80	221.40	442.80	664.20	885.60	1328.40	1771.20	2656.80
	HF60FG-INS	White	24282	38.53	115.59	231.88	346.77	462.36	693.54	924.72	1387.08
HF70	HF70SD-INS	Orange	30438	48.30	144.90	289.80	434.70	579.60	869.40	1159.20	1738.80
	HF70MD-INS	Green	60430	95.88	287.64	575.28	862.92	1150.56	1725.84	2301.12	3451.68
	HF70HT-INS	Grey	60430	95.88	287.64	575.28	862.92	1150.56	1725.84	2301.12	3451.68
	HF70FG-INS	White	30438	48.30	144.90	289.80	434.70	579.60	869.40	1159.20	1738.80
HF80	HF80SD-INS	Orange	59430	94.30	282.90	565.80	848.70	1131.60	1697.40	2263.20	3394.80
	HF80MD-INS	Green	114227	181.24	543.72	1087.44	1631.16	2174.88	3262.32	4349.76	6524.64
	HF80HT-INS	Grey	114227	181.24	543.72	1087.44	1631.16	2174.88	3262.32	4349.76	6524.64
	HF80FG-INS	White	59430	94.30	282.90	565.80	848.70	1131.60	1697.40	2263.20	3394.80
HubFlex™ flexible couplings can sustain momentary peak torque loads in excess of 200% of its maximum torque rating.											

DOWNLOAD AVAILABLE CAD MODELS AT: WWW.HUBCITYINC.COM

Certified prints are available upon request

CALL: (605) 225-0360 • FAX: (605) 225-0567

Hub City HubFlex™ Coupling

Torque Ratings

Torque Ratings for HubFlex™ Couplings with Extreme Duty Cover

Coupling Series	Insert Part #	Insert Color	Continuous Torque (in-lbs)	HP Ratings @ Various RPM (Service Factor = 1)							
				100	300	600	900	1200	1800	2400	3600
HF20	HF20SD-INS	Orange	1254	1.99	5.97	11.94	17.91	23.88	35.82	47.76	71.64
	HF20MD-INS	Green	2457	3.90	11.70	23.40	35.10	46.80	70.20	93.60	140.40
	HF20XD-INS	Black	3789	6.01	18.03	36.06	54.09	72.12	108.18	144.24	216.36
	HF20HT-INS	Grey	2457	3.90	11.70	23.40	35.10	46.80	70.20	93.60	140.40
	HF20FG-INS	White	1254	1.99	5.97	11.94	17.91	23.88	35.82	47.76	71.64
HF30	HF30SD-INS	Orange	4099	6.50	19.50	39.00	58.50	78.00	117.00	156.00	234.00
	HF30MD-INS	Green	7730	12.26	36.78	73.56	110.34	147.12	220.68	294.24	441.36
	HF30XD-INS	Black	11914	18.90	56.70	113.40	170.10	226.80	340.20	453.60	680.40
	HF30HT-INS	Grey	7730	12.26	36.78	73.56	110.34	147.12	220.68	294.24	441.36
	HF30FG-INS	White	4099	6.50	19.50	39.00	58.50	78.00	117.00	156.00	234.00
HF40	HF40SD-INS	Orange	8630	13.69	41.07	82.14	123.21	164.28	246.42	328.56	492.84
	HF40MD-INS	Green	17099	27.13	81.39	162.78	244.17	325.56	488.34	651.12	976.68
	HF40XD-INS	Black	25870	41.05	123.15	246.30	369.45	492.60	738.90	985.20	1477.80
	HF40HT-INS	Grey	17099	27.13	81.39	162.78	244.17	325.56	488.34	651.12	976.68
	HF40FG-INS	White	8630	13.69	41.07	82.14	123.21	164.28	246.42	388.56	492.84
Estimated Torque Ratings for Additional Sizes Available Soon:											
HF50	HF50SD-INS	Orange	17315	27.47	82.41	164.82	247.23	392.64	494.46	659.28	988.92
	HF50MD-INS	Green	34336	54.48	163.44	326.88	490.32	653.76	980.64	1307.52	1961.28
	HF50XD-INS	Black	52408	83.15	249.45	498.90	748.35	997.80	1496.70	1995.60	2993.40
	HF50HT-INS	Grey	34336	54.48	163.44	326.88	490.32	653.76	980.64	1307.52	1961.28
	HF50FG-INS	White	17315	27.47	82.41	164.82	247.23	392.64	494.46	659.28	988.92
HF60	HF60SD-INS	Orange	30353	48.16	144.48	288.96	433.44	577.92	866.88	1155.84	1733.76
	HF60MD-INS	Green	58137	92.24	276.72	553.44	830.16	1106.88	1660.32	2213.76	3320.64
	HF60XD-INS	Black	87110	138.21	414.63	829.26	1243.89	1658.52	2487.78	3317.04	4975.56
	HF60HT-INS	Grey	58137	92.24	276.72	553.44	830.16	1106.88	1660.32	2213.76	3320.64
	HF60FG-INS	White	30353	48.16	144.48	288.96	433.44	577.92	866.88	1155.84	1733.76
HF70	HF70SD-INS	Orange	38048	60.37	181.11	362.22	543.33	724.44	1086.66	1448.88	2173.32
	HF70MD-INS	Green	75538	119.85	359.55	719.10	1078.65	1438.20	2157.30	2876.40	4314.60
	HF70XD-INS	Black	116432	184.74	554.22	1108.44	1662.66	2216.88	3325.32	4433.76	6650.64
	HF70HT-INS	Grey	75538	119.85	359.55	719.10	1078.65	1438.20	2157.30	2876.40	4314.60
	HF70FG-INS	White	38048	60.37	181.11	362.22	543.33	724.44	1086.66	1448.88	2173.32

HubFlex™ flexible couplings can sustain momentary peak torque loads in excess of 200% of its maximum torque rating.

DOWNLOAD AVAILABLE CAD MODELS AT: WWW.HUBCITYINC.COM

Certified prints are available upon request

EMAIL: hubsales@regalbeloit.com • www.hubcityinc.com



Hub City HubFlex™ Coupling

Misalignment Tolerances

HubFlex™ Couplings Misalignment Tolerances

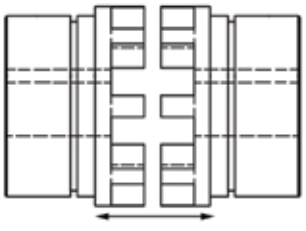
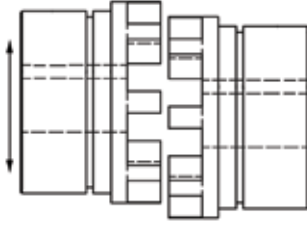
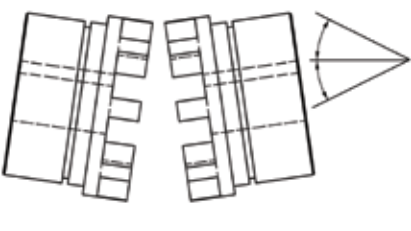
Coupling Series	Axial Misalignment Tolerance (in.)	Radial Misalignment Tolerance (in.)	Angular Misalignment Tolerance
HF10	0.078	0.020	2°
HF20	0.116	0.039	2°
HF30	0.116	0.039	2°
HF40	0.116	0.039	2°
Additional Sizes Available Soon:			
HF50	0.156	0.058	2°
HF60	0.175	0.058	1.3°
HF70	0.234	0.058	1.3°
HF80	0.234	0.058	1°
HF90	0.234	0.058	1°
HF100	0.312	0.058	1°
HF110	0.312	0.078	1°
HF120	0.312	0.078	1°
			

DOWNLOAD AVAILABLE CAD MODELS AT: WWW.HUBCITYINC.COM

Certified prints are available upon request

CALL: (605) 225-0360 • FAX: (605) 225-0567

Hub City HubFlex™ Coupling

Service Factors

HubFlex™ Couplings Service Factors

Application	Service Factor	Application	Service Factor
Aerators	2.50	Cutter Head, Jig Drive	2.50
Aggregate Processing, Cement, Mining Kilns		Maneuvering Winch	1.75
Direct or on Line Shaft of Reducer		Pumps (Uniform Load)	1.75
With Final Drive Machined Spur Gears	2.25	Screen Drive, Stacker	2.00
With Single Helical or Herringbone Gears	2.00	Utility Winch	2.00
Crushers, Ore or Stone	2.75	Dynamometer	1.50
Dryer, Rotary	2.00	Elevators - Bucket, Centrifugal Discharge	1.75
Grizzly	2.25	Exciter, Generator	1.50
Hammermill or Hog	2.00	Extruder, Plastic	1.50
Tumbling Mill or Barrel	2.00	Fans	
Agitators		Centrifugal	1.25
Vertical, Horizontal, Screw, Propeller, Paddle	1.25	Cooing Tower	2.00
Barge Haul Puller	1.75	Forced Draft-Across the Line Start	1.75
Blowers		Food Industry	
Centrifugal	1.50	Beet Slicer	2.00
Lobe or Vane	1.50	Bottling, Can, Filling Machine	1.50
Brewing and Distilling		Cereal Cooker	1.50
Bottle and Can Filling Machines	1.50	Dough Mixer, Meat Grinder	2.00
Brew Kettle	1.25	Forced Draft Motor driven thru fluid or Electric Slip Clutch	1.25
Cookers, Continuous Duty	1.50	Gas Recirculating	1.50
Lauter Tub	1.75	Induced Draft with damper control or blade cleaner	1.50
Mash Tub	1.50	Induced Draft without controls	2.00
Scale Hopper, Frequent Peaks	2.00	Feeders	
Clarifier Or Classifier	1.25	Apron, Belt, Disc, Screw	1.25
Clay Working Industry		Reciprocating	2.50
Brick Press, Briquette Machine, Clay Working Machine, Pug Mill	2.00	Generators	
Compressors		Even Load	1.25
Centrifugal	1.25	Hoist or Railway Service	1.75
Rotary, Lobe or Vane	1.50	Welder Load	2.00
Rotary, Screw	1.50	Hammermill	1.75
Reciprocating		Laundry Washer Or Tumbler	2.00
Direct Connected	Refer to Factory	Line Shafts Any Processing Machinery	1.50
Without Flywheels	Refer to Factory	Lumber	
With Flywheel and Gear between Compressor and Prime Monitor		Band Resaw	2.00
1 Cylinder, Single Acting	3.00	Circular Resaw, Cutoff	2.00
1 Cylinder, Double Acting	3.00	Edger, Head Rig, Hog	2.50
2 Cylinders, Single Acting	3.00	Gang Saw (Reciprocating)	3.00
2 Cylinders Double Acting	3.00	Log Haul	2.50
3 Cylinders Single Acting	3.00	Planer	2.00
3 Cylinders, Double Acting	2.00	Rolls, Non-Reversing	1.50
4 Or More Cyl. Single Acting	2.50	Rolls, Reversing	2.50
4 Or More Cyl. Double Acting	2.50	Sawdust Conveyor	1.50
Conveyors		Slab Conveyor	2.00
Apron, Assembly, Belt, Chain, Flight, Screw	1.75	Sorting Table	1.75
Bucket	1.75	Trimmer	2.00
Live Roll, Shaker and Reciprocating	3.00	Machine Tools	
Bridge, Travel or Trolley	2.50	Auxiliary and Traverse Drive	1.00
Dredgers			
Cable Reel	2.00		
Conveyors	1.50		

DOWNLOAD AVAILABLE CAD MODELS AT: WWW.HUBCITYINC.COM

Certified prints are available upon request

EMAIL: hubsales@regalbeloit.com • www.hubcityinc.com



Hub City HubFlex™ Coupling

Service Factors

HubFlex™ Couplings Service Factors

Application	Service Factor	Application	Service Factor
Bending Roll, Notching Press, Punch, Press, Planer, Plate Reversing ...	1.75	Oil Industry	
Main Drive	1.50	Chiller	1.50
Metal Rolling Mills		Oilwell Pumping (not over 150% peak torque)	2.50
Coilers (Up or Down) Cold Mill Only	1.75	Paraffin Filter Press	1.75
Coilers (Up or Down) Hot Mill Only	2.25	Rotary Kiln	2.50
Coke Plants		Paper Mills	
Pusher Ram Drive	2.75	Barker, Auxiliary, Hydraulic	2.50
Door Opener	2.25	Barker, Mechanical	2.50
Pusher or Larry Car Traction Drive	3.25	Barker, Drum L.S. shaft of reducer with final drive-	
Continuous Caster	2.00	Helical or Herringbone Gear	5.00
Cold Mills		Machined Spur Gear	3.00
Strip Mills	Refer to Factory	Cast Tooth Spur Gear	3.00
Temper Mills	Refer to Factory	Beater & Pulper	2.00
Cooling Beds	1.75	Bleachers, Coaters	1.50
Drawbench	2.25	Calendar & Super Calendar	2.00
Feed Rolls - Blooming Mills	3.25	Chipper	3.00
Furnace Pushers	2.25	Converting Machine	1.50
Hot and Cold Saws	2.25	Couch	2.00
Hot Mills		Cutter, Felt Whipper	2.25
Strip or Sheet Mills	Refer to Factory	Cylinder, Dryer	2.00
Reversing Blooming	Refer to Factory	Felt Stretcher	1.75
Slabbing Mills	Refer to Factory	Fourdrinier	2.00
Edger Drives	Refer to Factory	Jordan	2.50
Ingot Cars	2.25	Log Haul	2.50
Manipulators	3.25	Line Shaft	1.75
Merchant Mills	Refer to Factory	Press	2.00
Mill Tables		Pulp Grinder	2.00
Roughing Breakdown Mills	3.25	Reel, Rewinder, Winder	2.00
Hot Bed or Transfer (non-reversing)	1.75	Stock Chest, Washer, Thickener	1.75
Runout (reversing)	3.25	Stock Pumps, Centrifugal	
Runout (non-reversing, non-plugging)	2.25	Constant Speed	1.25
Reel Drives	2.00	Frequent Speed Changes Under Load	1.50
Rod Mills	Refer to Factory	Suction Roll	2.00
Screwdown	2.25	Press, Printing	1.50
Seamless Tube Mills		Pug Mill	1.75
Piercer	3.25	Pulverizers	
Thrust Block	2.25	Hammermill and Hog	1.75
Tube Conveyor Rolls	2.25	Roller	1.50
Reeler	2.25	Pumps Centrifugal	
Kick Out	2.25	Constant Speed	1.00
Shear, Croppers	Refer to Factory	Frequent Speed Changes Under Load	1.75
Sideguards	3.25	Descaling, with Accumulators	1.75
Skelp Mills	Refer to Factory	Gear, Rotary, or Vane	1.75
Slitters (Steel Mill only)	2.00	Pumps Reciprocating	
Soaking Pit Cover Drives		1 Cyl., single or double acting	3.00
Lift	1.25	2 Cyl., single acting	2.50
Travel	2.25	2 Cyl., double acting	2.00
Straighteners	2.25	3 or more cylinders	2.00
Unscramblers (Billet Bundle Busters)	2.25		
Wire Drawing Machinery	2.00		
Mixers (also see Agitators)			
Concrete	1.75		
Muller	1.50		

DOWNLOAD AVAILABLE CAD MODELS AT: WWW.HUBCITYINC.COM

Certified prints are available upon request

CALL: (605) 225-0360 • FAX: (605) 225-0567

Hub City HubFlex™ Coupling

Service Factors

HubFlex™ Couplings Service Factors

Application	Service Factor
Rubber Industry	
Calendar	2.25
Cracker, Plasticolour	2.50
Extruder	2.00
Tire & Tube Press Opener (peak torque)	1.50
Warming Mill	
One or two mills in line	2.00
Three or more mills in line	2.50
Washer	2.75
Screens	
Air Washing	1.50
Grizzly	2.50
Rotary Coal or Sand	2.00
Vibrating	2.50
Water	1.50
Sewage Disposal Equipment	
Bar Screen, Chemical Feeders, Collectors,	
Dewatering Screen, Grit Collector	1.50
Mill Stands, Turbine Driven with all Helical or Herringbone Gears	1.75
Electric Drive or Steam Engine Drive with Helical or Herringbone	2.00
Stoker	1.00
Sugar Industry	
Cone Carrier and Leveler	2.25
Cane Knife and Crusher	2.50
Mill Stands, Turbine Driver with all helical or Herringbone Gears	1.75
Electric Drive or Steam Engine Drive with helical, Herringbone, or Spur Gears with any Prime Mover	2.00
Textile Industry	
Batcher	1.50
Calendar, Card Machine	1.75
Cloth Finishing Machine	1.75
Dry Can, Loom	1.75
Dyeing Machinery	1.50
Knitting Machine	Refer to Factory
Mangle, Napper, Soaper	1.50
Spinner, Tenter Frame, Winder	1.75
Tumbling Barrel	2.00
Winch, Maneuvering - Dredge, Marine	1.50
Windlass	1.50

Engine Service Factors

Service Factors for engine drives are those required for applications where good flywheel regulation prevents torque fluctuation greater than 20%. For drives where torque fluctuations are greater or where the operation is near a serious critical or torsional vibration, a mass elastic study is necessary.

To determine an engine drive service factor, first determine the application service factor for motors. Then, use that to find the correct engine service factor in the table below. When the application service factor for motors is greater than 2.0 or where 1, 2, or 3 cylinder engines are involved, please contact customer service with complete application details for engineering review.

Application Service Factor	Engine Factor	
	4 to 5 Cylinders	6+ Cylinders
1.00	2.000	1.500
1.25	2.250	1.750
1.50	2.500	2.000
1.75	2.750	2.250
2.00	3.000	2.500



Hub City HubFlex™ Coupling

Compatibility Chart

A = Little to No Effect; B = Minor to Moderate Effect; C = Severe Effect to Destruction; N = No Data; Test Prior to Use

Acetaldehyde	C	Bleach Solutions	N	Freon, 12 or 113	A	Paimitic Acid	A
Acetamide	N	Boric Acid	A	Fuel Oil	B	Paint Thinner	B
Acetic Acid	C	Brake Fluid	N	Gasoline	B	Peanut Oil	A
Acetic Anhydride	C	Bromine	B	Glucose	A	Perchloric Acid	C
Acetone	C	Bunker Oil	A	Glue	N	Perchloroethylene	C
Acetyl Bromide	C	Butane	A	Glycerin	A	Petroleum	B
Acetyl Chloride	C	Butyl Acetate	C	Heptane	A	Phenol (carbolic acid)	C
Acetylene	C	Butyl Alcohol	B	Hexane	A	Phosphoric Acid	C
Adipic Acid	A	Calcium Carbonate	B	Hydrazine	C	Potassium Cyanide	A
Aero Shell Grease	B	Calcium Chloride	A	Hydrobromic Acid	B	Potassium Salts	B
Aero Lubriplate	A	Calcium Hydroxide	A	Hydrocarbon Oil	A	Propane	B
Aero Safe 2300	N	Calcium Nitrate	B	Hydrochloric Acid	B	Propyl Alcohol	B
Aerozene 50	N	Calcium Sulfate	B	Hydrofluoric Acid	B	Propylene Glycol	B
Aluminum Acetate	N	Carbon Dioxide	A	Hydrogen	A	Pydraul Oil	C
Aluminum Bromide	N	Carbon Disulfide	B	Hydrogen Peroxide	B	SAE #10 Oil	A
Aluminum Chloride	B	Carbon Monoxide	A	Hydrogen Sulfide	C	Seawater	A
Aluminum Sulfate	B	Carbon Tetrachloride	C	Hydrologic Acid	B	Silicic Acid	B
Ammonia	B	Chlorine	N	Iodine	A	Silver Nitrate	B
Ammonium Carbonate	B	Chloroacetic Acid	C	Isobutyl Alcohol	N	Skydrol Oil	C
Ammonium Chloride	N	Chloroform	C	Isopropyl Chloride	N	Soap	B
Ammonium Hydroxide	B	Chromic Acid	C	Isopropyl Ether	B	Sodium Acetate	A
Ammonium Nitrate	B	Chromium Potassium Sulfate	B	Isopropyl Alcohol (Propanol)	B	Sodium Bicarbonate	B
Ammonium Persulfate	B	Citric Acid	B	JP4 Oil	B	Sodium Borate	B
Ammonium Sulfate	B	Corn Oil	A	JP5 & 6 Oil	C	Sodium Carbonate	B
Ammonium Sulfide	B	Cottonseed Oil	A	Kerosene	B	Sodium Chloride	B
Ammonium Thiocyanate	B	Cresol	C	Lactic Acid	B	Sodium Cyanide	B
Amonnium Acetate	C	Crude Oil	B	Lead Acetate	B	Sodium Hydrosulfite	B
Amyl Acetate	C	Cupric Chloride	A	Linseed Oil	B	Sodium Hydroxide	B
Amyl Alcohol	C	Cupric Nitrate	B	Liquefied Petroleum Gas	A	Sodium Hypochlorite	C
Aniline	C	Cupric Sulfate	B	Lubrication Oil	B	Sodium Nitrate	B
Aniline Hydrochloride	C	Cutting Oil	B	Lye	N	Sodium Silicate	A
Animal Fats & Oils	B	Cyclohexane	B	Magnesium Chloride	N	Sodium Sulfate	B
Antimony Salts	B	Cyclohexanone	C	Magnesium Hydroxide	A	Sodium Sulfide	B
Aqua Regia	C	Dibutyl Phthalate	C	Magnesium Salts	B	Steam	C
Arsenic Salts	B	Dichlorobenzene	C	Malaic Acid	C	Styrene	B
ASTM Oil #1	A	Diesel Fuel	B	Mercury	B	Sulfur Dioxide	B
ASTM Oil #2	B	Diester Oil	B	Methyl Alcohol (methanol)	A	Sulfuric Acid	C
ASTM Oil #3	B	Dimethyl Acetamide	C	Methyl Ethyl Ketone	C	Tannic Acid	A
ASTM Reference Fuel	A	Dimethyl Formamide	C	Methylene Chloride	C	Tartaric Acid	A
ASTM Reference Fuel	B	Dodecyl Mercaptan	B	MIL-D-5606 Oil	C	Toluene	C
Atlantic Oil	A	DTE Oil	B	MIL-L-7808 Oil	B	Transformer Oil	B
Barium Carbonate	B	Dibutyl Ether	B	Mineral Oil	A	Turpentine	C
Barium Hydroxide	A	EP Lubes	A	Mineral Spirits	N	Urea	B
Beer	A	Esso #90 Lube Oil	A	Naphthalene	B	Varnish	B
Benzaldehyde	B	Ether	B	Natural Gas	B	Water	B
Benzene	C	Ethyl Acetate	C	Nickel Salts	C		
Benzoic Acid	B	Ethyl Alcohol (Ethanol)	C	Oxygen	A		
Black Sulphate Liquors	N	Formic Acid	C	Ozone	A		

DOWNLOAD AVAILABLE CAD MODELS AT: WWW.HUBCITYINC.COM

Certified prints are available upon request

CALL: (605) 225-0360 • FAX: (605) 225-0567

Hub City HubFlex™ Coupling

Safety Guidelines

SAFETY GUIDELINES

When using HubFlex™ Couplings, you must follow the installation instructions and take the following precautions. Failure to do so may cause the HubFlex™ Coupling(s) to break and parts to be thrown with sufficient force to cause severe injury or death.



Refer to this catalog for proper selection, sizing, horsepower, torque range, and speed range of HubFlex™ Couplings. Follow the installation instructions included with the product. Do not exceed catalog ratings.

During start up and operation of HubFlex™ Couplings, avoid sudden shock loads. HubFlex™ Coupling assembly should operate quietly and smoothly. If HubFlex™ Coupling assembly vibrates or makes beating sound, shut down immediately, and recheck alignment. Shortly after initial operation and periodically thereafter, where applicable, inspect HubFlex™ Coupling assembly for: alignment, wear of elastomeric element, and flexing elements for signs of fatigue. Do not operate HubFlex™ Coupling assembly if alignment is improper, or if elastomeric element is damaged or worn.

Do not use any HubFlex™ Couplings for elevators, man lifts, or other devices that carry people. If the HubFlex™ Coupling fails, the lift device could fall resulting in severe injury or death.

For all HubFlex™ Couplings, you must install suitable guards in accordance with OSHA and American Society of Mechanical Engineers Standards. Do not start HubFlex™ Coupling before suitable guards are in place. Failure to properly guard these products may result in severe injury or death from personnel contacting moving parts or from parts being thrown from assembly in the event the HubFlex™ Coupling product fails.

If you have any questions, contact your Hub City, Inc. Sales Representative - www.hubcityinc.com

Hub City HubFlex™ Coupling

Quick Selection Guide



Insert Features

Standard duty (Orange)	Medium Duty (Green)	Extreme Duty (Black)	High Temp (Gray)	Food Grade (White)
Max Temp: 212 F	Max Temp: 212 F	Max Temp: 212 F	Max Temp: 350 F	Max Temp: 212 F
Greatest Dampening	Lower Dampening	Lowest Dampening	Dampening & Torque	Dampening & Torque
Lowest Torque	Higher Torque	Highest Torque	Same as Green	Same as Orange
				FDA Approved Material

MAX TORQUE RATING (in. lbs.) With EXTREME DUTY Cover

Max Bore	Coupling Series	Orange	Green	Black	Hi-Temp	Food Grade
1-5/8"	HF20	1254	2457	3789	2457	1254
2-1/4"	HF30	4099	7730	11914	7730	4099
2-3/8"	HF40	8630	17099	25870	17099	8630
Estimated Torque Ratings for Additional Sizes Available Soon:						
3"	HF50	17315	34336	52408	34336	17315
3-7/8"	HF60	30353	58137	87110	58137	30353
4-1/8"	HF70	38048	75538	116432	75538	38048
4-1/2"	HF80	75000	145000	220000	145000	75000
5-1/2"	HF90	105000	204000	310000	204000	105000
7"	HF100	175000	345000	550000	345000	175000
8"	HF110	300000	565000	870000	565000	300000
11"	HF120	NA	1120000	1680000	1120000	NA

MAX TORQUE RATING (in. lbs.) With STANDARD Cover

Max Bore	Coupling Series	Orange	Green	Black	Hi-Temp	Food Grade
1-1/4"	HF10	365	792	792	792	365

DOWNLOAD AVAILABLE CAD MODELS AT: WWW.HUBCITYINC.COM

Certified prints are available upon request

CALL: (605) 225-0360 • FAX: (605) 225-0567

Hub City Farm Products And Accessories

Farm Products & Accessories Features	R-2
Safety Warnings	R-4, R-11
P. T. O. Adaptors	
Splined – Standard Duty to 75 HP	R-6
Splined – Heavy Duty to 125 HP	R-6
Kwik-D-Tach Splined to 75 HP	R-7
Splined – Standard Duty for Tractors	
with 1 3/4-20 Splined P.T.O. to 75 HP.....	R-7
Splined – Heavy Duty for Tractors	
with 1 3/4-20 Splined P.T.O. to 125 HP.....	R-7
“Forged” – Standard Duty to 75 HP.....	R-8
Push-Pin Type to 75 HP	R-8
Round Shaft to 75 HP	R-8
Clamp Type to 75 HP	R-8
Sleeve Type Splined to 75 HP	R-8
Over-Running Couplers	
Kwik-D-Tach Tractor Models to 125 HP	R-10
Tractor Models to 75 HP	R-10
Utility Models to 75 HP	R-15
Universal Models to 75 HP.....	R-15
Special Models	R-15
Splined Couplings	
Splined Couplings	R-12
Involute Splined Couplings	R-12
Hydraulic Reducer Bushings	R-12
Splined Shafts	
Splined Shafts	R-13
Extension Shafts	R-13
Involute Splined Shafts.....	R-13
Weld-On Adaptors	
Splined Weld-Ons	R-9
Quick Release Weld-Ons	R-9
Square Bushing Weld-Ons	R-11
Sprocket Repair Hub for Transit-Mixer	R-11
Couplings and Splined Hubs	
Round Bore Couplings.....	R-14
Precision Splined Hubs.....	R-14
P.T.O. Pump Drive Adaptors	
Kwik-D-Tach Splined	R-9
Splined Pump Drive	R-9
Stroke Control Segments for Hydraulic Cylinders	R-16
Over-Hung Load Adaptor for Orbit Motors	R-17
Model 330 Pump Drive	R-18 & R-19
Lubrication & Installation instructions.....	See Section S
Shipping Weights & Index	R-20

Hub City Farm Products And Accessories

Features:

- Power Ratings Up to 125 hp
- Splined PTO Adapters to Fit Most Tractor and Implement Shafting
- Kwik-D-Tach Connections for Safe and Secure Attachments
- Forged Adapters for High Horsepower Applications
- Clamp Type Adapters for Safe Permanent Installations
- Over-Running Couplers for Handling High-Inertia PTO Applications
- Splined Shafts, Couplings and Hubs for Convenient Design and Fabrications
- Stroke Control Segments for Hydraulic Cylinders
- Overhung Load Adapters for Orbit Motors
- Pump Drives for PTO Driven Hydraulic Pumps



Options:

- Special Over-Running Coupler
- Modified and Custom Shafts, Hubs and Couplings
- Contact Hub City with Your Design Requirements!



DOWNLOAD AVAILABLE CAD MODELS AT: WWW.HUBCITYINC.COM

Certified prints are available upon request

CALL: (605) 225-0360 • FAX: (605) 225-0567

Hub City Farm Products And Accessories

Warranty

Hub City Inc. warrants product to be free from defect in material and workmanship for one year from date of shipment. The company will repair or replace, F.O.B. shipping point, any item found to be defective upon

inspection at Hub City's factory in Aberdeen, South Dakota within one year from date of shipment. See Terms and Conditions of Sale at the end of this catalog for complete warranty and limitation of liability statement.

Adjustment Policy

SPLINED SHAFT ADAPTORS: Broken or damaged Splined Shaft Adaptors returned directly to the factory

in Aberdeen, South Dakota, will be replaced on a no-charge basis.

FOR USER/OPERATOR SAFETY, SEE DETAILS ON PAGES R-4, R-5 & R-11

How To Order

When ordering Hub City Farm Products and Accessories specify the part number and quantity for each item ordered. Orders may be placed by mail, telephone, fax or e-mail.

Hub City Inc.
Box 1089
Aberdeen, SD 57401

Telephone: 605/225-0360 Fax: 605/225-0567
E-Mail: sales@hubcityinc.com
Website: www.hubcityinc.com

DOWNLOAD AVAILABLE CAD MODELS AT: WWW.HUBCITYINC.COM

Certified prints are available upon request

EMAIL: hubsales@regalbeloit.com • www.hubcityinc.com



Hub City Farm Products And Accessories



IMPORTANT INFORMATION! PLEASE READ BEFORE USING PRODUCT



PTO MOUNTED ACCESSORY SAFETY INSTRUCTION

The application of Hub City farm products/accessories may expose rotating implement drive line components from the equipment guarding and/or extend the tractor P.T.O. shaft and/or contract the implement drive line.

For the safety of the user/operator, the purchaser or his/her designee must shield and guard any exposed rotating components and extend the hitch point or shorten the implement drive line to accommodate the use of these products/accessories.

For the safety of the user/operator, the Hub City products in this catalog identified by this symbol  must be used only on the tractor P.T.O. shaft.

APPLICATION

Mounting a Hub City PTO accessory on your tractor changes the relationship between the end of the operating (rotating) PTO shaft and the end of the tractor master power take-off (PTO) shield.



This change can result in exposed rotating implement drive line components and if left unguarded can result in serious injury or death to the user/operator.

To use this Hub City PTO accessory, you **MUST** extend the tractor master PTO shield to provide proper guarding of the implement PTO drive line.

The tractor to which you will be mounting this Hub City Power Take-off (PTO) accessory, must be equipped with an ASAE approved Tractor Master Power Take-Off (PTO) Shield supplied by the tractor manufacturer or constructed to American Society of Agricultural Engineers Standards and a Power Take-Off (PTO) Shield Extension as identified below and in Figure No. 1. If the tractor will not have these two (2) shields, **DO NOT** mount or use this PTO accessory.



Failure to properly guard can result in serious injury or death.

Your PTO driven implement **MUST BE** equipped with a shielded drive line at all times when using this Hub City power take-off accessory! If your PTO driven implement drive line is equipped with a tunnel type drive line shield that is attached to the drive line pedestal on the implement and attaches to the slot and tang on the tractor master power take-off (PTO) shield, that allows the tunnel shield to telescope as you turn corners, **DO NOT** use the implement with this or any other Hub City PTO accessory. The tractor master power take-off shield extension shown in Figure No. 1, covers the tractor master power-take off shield slot and tang and will not allow the attachment of the tunnel type drive line shield.



Before mounting the PTO device on the tractor power take-off (PTO) shaft, and configuring and mounting a PTO shield extension, disengage the tractor power take-off PTO shaft and shut off the tractor engine.

INSTRUCTIONS

The information below will guide you in extending the tractor master power take-off (PTO) shield. If you are unable or unwilling to extend the tractor master power take-off (PTO) shield do not use or mount this Hub City PTO Accessory on your tractor.

The requirements of a tractor master power take-off (PTO) shield and its relationship to the tractor power take-off (PTO) shaft, that will provide the specifications to extend your tractor master power take-off (PTO) shield, can be obtained from:

The American Society of Agricultural Engineers (ASAE) – 2950 Niles Road – St. Joseph, MI 49085-9659
Phone #616-429-0300, FAX #:616-429-3852, E-mail: hq@asae.org, Web: <http://asae.org/>
Ref: Std #S203.13, December 1999 or latest revision, front & rear power take-off for agricultural tractors.

Global Engineering Documents – 15 Inverness Way East – Englewood, CO 80112-5776
Phone #303-397-7956 or 800-854-7179, Fax #: 303-397-2740, E-mail global@ihs.com
Ref: ASAE Std S203-13 December 1999 or latest revision

Your tractor manufacturer, Ref: Your owner/operators manual for mailing address and phone number.

Your local implement dealer from whom you purchased your tractor or who provides similar tractors.

DOWNLOAD AVAILABLE CAD MODELS AT: WWW.HUBCITYINC.COM

Certified prints are available upon request

CALL: (605) 225-0360 • FAX: (605) 225-0567

Hub City Farm Products And Accessories



IMPORTANT INFORMATION! PLEASE READ BEFORE USING PRODUCT



In the construction of a tractor master power take-off (PTO) shield extension, the following information can be used as a guideline.

CAUTION DO NOT USE this power take-off shield extension guideline with PTO accessories NOT manufactured by Hub City.

The shield extension material must be steel, the same or a greater thickness than the steel used in the tractor master power take-off (PTO) shield.

The shield extension material should be formed to closely fit the contour of the inside of the tractor master power take-off (PTO) shield.

The shield extension should be fastened to the tractor master power take-off (PTO) shield with a minimum of (7) 5/16 NC Grade 5 bolts, with flat washers, lock washer and nut, (2) bolts on each side and (3) bolts on top of the shield extension.

CAUTION DO NOT USE the tractor master power take-off (PTO) shield or the shield extension as a step.

A generic guideline for the dimensional size & construction characteristics of a PTO shield extension are shown in Figure No. 1:

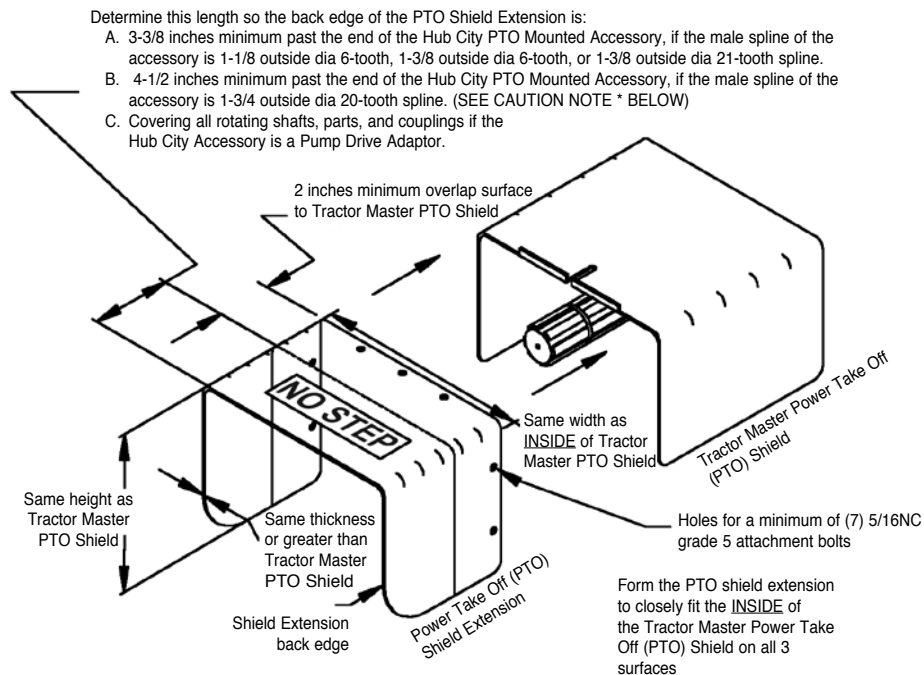

Figure No. 1

CAUTION *If this Hub City PTO mounted accessory has a 1-3/4 outside diameter 20-tooth male spline, and is being mounted on a 1-1/8 or 1-3/8 outside diameter 6-tooth or 1-3/8 outside diameter 21-tooth male spline tractor PTO shaft, the tractor master power take-off (PTO) shield on the tractor is narrower and closer to the tractor PTO shaft than a tractor equipped with a 1-3/4 20-tooth male spline PTO shaft. Using this adaptor and extending the tractor master power take-off (PTO) shield and extension during short turns or very uneven ground. If this condition is evident, the tractor master power take-off (PTO) shield and extension must be modified to provide sufficient implement drive line and drive line shield clearance.



The installation of this Hub City PTO accessory on your tractor also changes the relationship between the end of the operating PTO shaft and the tractor draw bar hitch point. This extended tractor PTO shaft condition may require you to extend the tractor hitch point, and/or shorten the implement drive line to reduce excessive drive line angularity, resulting from short turns or very uneven ground, and/or prevent the implement drive line from bottoming out, which may damage the Hub City accessory and/or equipment and result in injury to the user/operator.

DOWNLOAD AVAILABLE CAD MODELS AT: WWW.HUBCITYINC.COM

Certified prints are available upon request

EMAIL: hubsales@regalbeloit.com • www.hubcityinc.com



Hub City Farm Products And Accessories

P.T.O. Products



FOR USER/OPERATOR SAFETY
SEE DETAILS PAGE R-4

Splined Adaptors -To 75 HP

- Capacity to operate on tractors related to 75 P.T.O. HP
- Provide a means of connecting two dissimilar splines
- Welded steel construction for added strength
- Corrosion resistant finish
- Spring and retaining ring pin or setscrews furnished



FEMALE SPLINE	MALE SPLINE	LENGTH (INCHES)	EXTENDS TRACTOR P.T.O.		SECURED BY	PART NUMBER
			SHAFT END	SHAFT RETAINING GROOVE		
25mm-18	1 3/8-6	4 5/8	3 3/8	3 1/2	Cross Pin	0332-00084*
1 1/8-6	1 3/8-6	5 1/2	3 3/4	3 5/8	Cross Pin	0332-03531
1 1/8-6	1 1/8-6	5 1/2	3 3/4	3 5/8	Cross Pin	0332-00377*
1 3/8-6	1 1/8-6	6 1/2	4 3/8	4 1/4	Cross Pin	0332-00400
1 3/8-6	1 1/8-6	5 1/8	3 5/16	3 5/16	Cross Pin	0332-00420
1 3/8-6	1 3/8-6	6 1/2	4 3/8	3 7/8	Cross Pin	0332-00371
1 3/8-6	1 3/8-6	5 1/8	3 5/16	3 5/16	Cross Pin	0332-00378
1 3/8-21	1 3/8-6	6 1/2	4 3/8	3 7/8	Setscrew	0332-00373
1 3/8-21	1 3/4-20	7	5	4 1/2	Setscrew	0332-00070
1 3/4-6	1 3/8-6	6 1/2	4 3/4	4 5/8	Cross Pin	0332-00401

* Manufactured to order

Splined Adaptors -To 125 HP

- Capacity to operate on tractors related to 125 P.T.O. HP
- Developed for long and rugged use
- Alloy steel, heat treated for extra strength
- Corrosion resistant finish
- Setscrews furnished



FEMALE SPLINE	MALE SPLINE	LENGTH (INCHES)	EXTENDS TRACTOR P.T.O.		SECURED BY	PART NUMBER
			SHAFT END	SHAFT RETAINING GROOVE		
1 3/8-21	1 3/8-21	6 7/8	4 13/16	4 13/16	Setscrew	0332-00001
1 3/8-21	1 3/8-6	6 7/8	4 13/16	4 11/16	Setscrew	0332-00002
1 3/8-21	1 3/4-20	7 11/16	5 31/64	4 63/64	Clamp Type	0332-00094**
1 3/8-6	1 3/8-21	6 7/8	4 13/16	5 5/16	Setscrew	0332-00004
1 3/8-6	1 3/8-6	6 7/8	4 13/16	5 3/16	Setscrew	0332-00005*

** Not heat treated

* Manufactured to order

DOWNLOAD AVAILABLE CAD MODELS AT: WWW.HUBCITYINC.COM

Certified prints are available upon request

CALL: (605) 225-0360 • FAX: (605) 225-0567



Hub City Farm Products And Accessories

P.T.O. Products

FOR USER/OPERATOR SAFETY
SEE DETAILS PAGE R-4

Kwik-D-Tach Splined Adaptors -To 75 HP

- Capacity to operate on tractors rated to 75 P.T.O. HP
- Patented Quick Release Drive
- New P.T.O. Quick Release Concept – Spring Loaded –rotates about 30° by hand for quick release
- Dependable operation – no sticking pins. Always easily operated
- No sharp edges, protrusions, pins or other interferences to injure operators



⊗ See usage safety warning on page R-4

FEMALE SPLINE	MALE SPLINE	LENGTH (INCHES)	EXTENDS TRACTOR P.T.O.		PART NUMBER
			SHAFT END	SHAFT RETAINING GROOVE	
1 3/8-6	1 3/8-6	6 1/2	4 3/8	4 3/8	0332-00010
1 3/8-6	1 3/8-21	6 1/2	4 3/8	4 7/8	0332-00013
1 3/8-6	1 1/8-6	6 1/2	4 3/8	4 3/4	0332-00015*
1 3/8-21	1 3/8-6	6 1/2	4 3/8	3 7/8	0332-01373
1 3/8-21	1 3/8-21	6 1/2	4 3/8	4 3/8	0332-02121
Repair Kit					0332-00086

* Manufactured to order

Splined Adaptors -To 75 HP

For tractors with 1 3/4 - 20 Spline P.T.O.

⊗ See usage safety warning on page R-4

FEMALE SPLINE	MALE SPLINE	LENGTH (INCHES)	EXTENDS TRACTOR P.T.O.		SECURED BY	PART NUMBER
			SHAFT END	SHAFT RETAINING GROOVE		
1 3/4-20	1 3/8-6	8 3/16	5 3/16	5 3/16	Clamp Type	0332-01476
1 3/4-20	1 3/8-21	8 3/16	5 3/16	5 11/16	Clamp Type	0332-01477



Heavy-Duty Splined Adaptors -To 125 HP

For tractors with 1 3/4 - 20 Spline P.T.O.

⊗ See usage safety warning on page R-4

FEMALE SPLINE	MALE SPLINE	LENGTH (INCHES)	EXTENDS TRACTOR P.T.O.		SECURED BY	PART NUMBER
			SHAFT END	SHAFT RETAINING GROOVE		
1 3/4-20	1 3/8-6	8 3/16	5 3/16	5 3/16	Clamp Type	0332-01490
1 3/4-20	1 3/8-21	8 3/16	5 3/16	5 11/16	Clamp Type	0332-01491



Hub City Farm Products And Accessories

P.T.O. Products



FOR USER/OPERATOR SAFETY
SEE DETAILS PAGE R-4

“Forged” P.T.O. Adaptor – to 75 HP

- 1 1/8 - 6 Spline female – 1 3/8 - 6 Spline male PART NO. 0332-00018
- “Forged” internal spline
- Universal quick-detach slot and bolt holes – can be used with any American, British or European P.T.O. system
- Furnished with 5/16 x 1 1/16 spring pin for direct connection to P.T.O.
- Overall length: 3 – extends P.T.O. 1 1/8



Push-Pin Type P.T.O. Adaptors – to 75 HP

Quick Release Extension Adaptor

⊗ See usage safety warning on page R-4

FEMALE SPLINE	MALE SPLINE	LENGTH (INCHES)	EXTENDS TRACTOR P.T.O.		PART NUMBER
			SHAFT END	SHAFT RETAINING GROOVE	
1 3/8-6	1 3/8-21	6 1/2	4 3/8	4 7/8	0332-00092
1 3/8-21	1 3/8-6	6 1/2	4 3/8	3 7/8	0332-01375
Repair Kit				Old Style	0335-90120
				New Style	0336-00182



Spring Type Release

Round Shaft Adaptors – to 75 HP

FEMALE ROUND	KEYWAY	MALE SPLINE	LENGTH	EXTENDS SHAFT	PART NUMBER
1	1/4	1 3/8-6	5 11/16	3 1/4	0332-00376
1 1/8	1/4	1 3/8-6	5 11/16	3 3/16	0332-00430
1 1/4	1/4	1 3/8-6	5 11/16	3 3/16	0332-00431
1 3/8	5/16	1 3/8-6	5 11/16	3 3/16	0332-00432
1 1/2	3/8	1 3/8-6	6 9/32	4	0332-00433



Clamp Type P.T.O. Adaptors – to 75 HP

⊗ See usage safety warning on page R-4

FEMALE SPLINE	MALE SPLINE	LENGTH (INCHES)	EXTENDS TRACTOR P.T.O.		PART NUMBER
			SHAFT END	SHAFT RETAINING GROOVE	
1 1/8-6	1 3/8-6	7 5/16	4 5/8	4 5/8	0332-01354
1 3/8-6	1 3/8-6	6 1/2	4 3/8	4 3/8	0332-00057
1 3/8-21	1 3/8-6	6 1/2	4 3/8	3 7/8	0332-00087



Sleeve Type Splined Adaptors – to 75 HP

FEMALE SPLINE	MALE SPLINE	LENGTH (INCHES)	PART NUMBER	SPECIAL APPLICATIONS
31/32-10	1 3/8-6	2 1/4	0332-00355	IHC Cub & Kubota
1 1/8-6	1 3/8-6	2 1/4	0332-00352	
1 1/8-6	1 3/8-6	2	0332-00363	Replaced Ford 231082
1 3/8-6	1 3/4-6	2 1/2	0332-00403*	



* Manufactured to order

DOWNLOAD AVAILABLE CAD MODELS AT: WWW.HUBCITYINC.COM

Certified prints are available upon request

CALL: (605) 225-0360 • FAX: (605) 225-0567



FOR USER/OPERATOR SAFETY
SEE DETAILS PAGE R-4

Hub City Farm Products And Accessories

P.T.O. Products

Kwik-D-Tach Splined Pump Drive Adaptors

Same safe, dependable, fast action release as Kwik-D-Tach Splined Adaptors

⊗ See usage safety warning on page R-4

FEMALE SPLINE	FEMALE ROUND**	KEYWAY	LENGTH(INCHES)	PART NUMBER
1 3/8-6	.625	3/16 x 3/32	4 1/8	0332-00012
1 3/8-6	.750	3/16 x 3/32	4 1/8	0332-00014
1 3/8-6	.875	3/16 x 3/32	4 1/8	0332-00011
1 3/8-6	.937	1/4 x 1/8	4 1/8	0332-00040
1 3/8-6	1.000	1/4 x 1/8	4 1/8	0332-00016
1 3/8-6	1.125	1/4 x 1/8	4 1/8	0332-00017

** Nominal + .002



Splined Pump Drive Adaptors

1 3/8 - 21 Spline Pump Drives are supplied with setscrews

FEMALE SPLINE	FEMALE ROUND**	KEYWAY	LENGTH(INCHES)	PART NUMBER
1 1/8-6	1.000	1/4 x 1/8	3 1/16	0332-00412
1 3/8-6	.625	3/16 x 3/32	4 1/8	0332-00407
1 3/8-6	.750	3/16 x 3/32	4 1/8	0332-00408
1 3/8-6	.875	3/16 x 3/32	4 1/8	0332-00409
1 3/8-6	.937	1/4 x 1/8	4 1/8	0332-00413
1 3/8-6	1.000	1/4 x 1/8	4 1/8	0332-00410
1 3/8-6	1.125	1/4 x 1/8	4 1/8	0332-00411
1 3/8-21	.625	3/16 x 3/32	4 1/8	0332-00607
1 3/8-21	.750	3/16 x 3/32	4 1/8	0332-00608
1 3/8-21	.937	1/4 x 1/8	4 1/8	0332-00612
1 3/8-21	1.000	1/4 x 1/8	4 1/8	0332-00610
1 3/8-21	1.125	1/4 x 1/8	4 1/8	0332-00611*

** Nominal + .002

* Manufactured to order



Splined Weld-Ons

DESCRIPTION	PART NUMBER
1 1/8-6 Spline, 5 1/4 Long	0332-00358
1 3/8-6 Spline, 5 1/2 Long	0332-00359
1 3/8-21 Spline, 5 1/2 Long	0332-00019



Quick Release Weld-Ons

⊗ See usage safety warning on page R-4

DESCRIPTION	PART NUMBER
1 3/8-21 Spline, 3 5/16 Long	0332-01350*
1 3/8-6 Spline, 3 5/16 Long	0332-01345

* Manufactured to order



DOWNLOAD AVAILABLE CAD MODELS AT: WWW.HUBCITYINC.COM

Certified prints are available upon request

EMAIL: hubsales@regalbeloit.com • www.hubcityinc.com



Hub City Farm Products And Accessories

P.T.O. Products



FOR USER/OPERATOR SAFETY
SEE DETAILS PAGE R-4

Over-Running Couplers

HUB CITY Over-Running Couplers provide a safe way to protect operators and machinery where inertia of driven units: e.g. rotary mowers, balers, hay conditioners, etc. can over-run driving source. They take the push out of

the driven machine and eliminate the chance of broken or twisted P.T.O. shafts. Over-Running Couplers drive solidly from tractor to driven implement, but over-run smoothly when implement exceeds P.T.O. speeds.

Kwik-D-Tach Tractor Models - to 125 HP

- Patent applied for – pending serial No. U.S. 465 641 – Canadian 1 117 114
- Capacity to operate on tractors to 125 P.T.O. HP
- New P.T.O. Quick Release Concept – Spring Loaded – rotates about 30° by hand for quick release
- Designed to operate with 1000 RPM P.T.O.'s
- Installation and lubrication instructions enclosed with each coupler



⊗ See usage safety warning on page R-4

FEMALE SPLINE	MALE SPLINE	LENGTH (INCHES)	EXTENDS TRACTOR P.T.O.		PART NUMBER
			SHAFT END	SHAFT RETAINING GROOVE	
1 3/8-6	1 3/8-6	7 5/16	4 3/16	5 3/16	0331-00010
1 3/8-6	1 3/8-21	7 3/16	4 11/16	5 3/16	0331-00011
1 3/8-21	1 3/8-6	7 5/16	5 5/16	5 3/16	0331-00012
1 3/8-21	1 3/8-21	7 3/16	5 3/16	5 3/16	0331-00013
Repair Kit					0337-00126

Tractor Models - to 75 HP

Over-Running Couplers covered by Patent No. 3,233,471 – Canadian Patent No. 727-982

- All steel welded housing
- Heat treated alloy steel inner sleeve
- Hardened steel keys, spring loaded
- Snap ring construction for quick, easy disassembly for cleaning and service
- Spring roll pin for quick mounting to tractor
- Convenient grease fitting for gun lubrication
- Designed to operate with 1000 RPM P.T.O.'s



SHIPPING WGT. 6 LBS.

⊗ See usage safety warning on page R-4

FEMALE SPLINE	MALE SPLINE	LENGTH (INCHES)	EXTENDS TRACTOR P.T.O.		FITS TRACTOR	PART NUMBER
			SHAFT END	SHAFT RETAINING GROOVE		
1 1/8-6	1 1/8-6	6 21/32	4 5/32	4 1/32	All with Cross Pin Hole Including Ford	0331-00690
1 1/8-6	1 3/8-6	6 21/32	4 5/32	4 1/32	All with Cross Pin Hole Including Ford	0331-00670
1 3/8-6	1 1/8-6	6 21/32	4 5/32	4 1/32	All with Cross Pin Hole Including Ford	0331-00680
1 3/8-6	1 3/8-6	6 21/32	4 5/32	4 1/32	All with Cross Pin Hole Including Ford	0331-00660
Repair Kit						0337-00076

Installation and lubrication instructions enclosed with each coupler.
For Non-PTO Over-running Couplers, refer to page R-15.

DOWNLOAD AVAILABLE CAD MODELS AT: WWW.HUBCITYINC.COM

Certified prints are available upon request

CALL: (605) 225-0360 • FAX: (605) 225-0567



FOR USER/OPERATOR SAFETY
SEE DETAILS PAGE R-11

Hub City Farm Products And Accessories

Non P.T.O. Products

Non P.T.O. Product Safety



For safety, purchaser or user must provide protective guards over all rotating shafts and any moving apparatus mounted thereon. The user is responsible for checking all applicable safety codes in his area and for the equipment utilizing this component, and providing suitable guards.

Buyer shall be solely responsible for determining the adequacy of this product for any and all uses to which the buyer shall apply this product. The application by the buyer shall not be subject to any implied warranty of fitness for a particular purpose. The purchaser/user of this component accepts responsibility for the above issues when removing the safety warning label from the component.



DO NOT OPERATE WITHOUT PROPER GUARDS. FAILURE TO GUARD CAN RESULT IN SERIOUS INJURY OR DEATH AND DAMAGE TO THE EQUIPMENT.

Square Bushing Weld-Ons

I.D.	O.D.	LENGTH (INCHES)	PART NUMBER
$\frac{7}{8}$ & 1 Square	1 $\frac{3}{4}$	2 $\frac{1}{4}$	0332-00360
1 $\frac{1}{8}$ Square	2	2 $\frac{1}{2}$	0332-00362
1 $\frac{1}{4}$ Square	2 $\frac{1}{4}$	2 $\frac{1}{2}$	0332-00364



Sprocket Repair Hub for Transit-Mixer

NO. OF SPLINES	SPLINE DESCRIPTION	SPLINE O.D.	SHOULDER O.D.	PILOT O.D.	PILOT LENGTH	O.A. LENGTH	PART NUMBER
23	8/16 INV.	3	4 $\frac{1}{2}$	4	1 $\frac{15}{32}$	3 $\frac{5}{64}$	0332-00045



Hub City Farm Products And Accessories

Non P.T.O. Products



FOR USER/OPERATOR SAFETY
SEE DETAILS PAGE R-11

Splined Couplings

SPLINED SIZE	O.D.	LENGTH (INCHES)	PART NUMBER
3/4-6	1 3/8	2 1/2	0332-00336
7/8-6	1 3/8	2 1/2	0332-00337
31/2-10 (IHC CUB & KUBOTA)	1 3/8	2 3/4	0332-00340
1-10	1 3/8	2 1/2	0332-00338
1-6	1 3/8	2 3/4	0332-00341
1 1/8-6	1 9/16	2 3/4	0332-00344
1 1/4-6	1 7/8	3 1/4	0332-00342
1 1/4-10	1 3/4	3 3/4	0332-00348
1 3/8-6	1 3/4	3 3/4	0332-00345
1 3/8-10	1 3/4	3	0332-00365
1 1/2-6	1 7/8	3 3/4	0332-00347
1 1/2-10	1 7/8	3	0332-00367
1 5/8-6	2	3 3/4	0332-00349
1 3/4-6	2 1/4	3 3/4	0332-00346



Involute Splined Couplings

NO. OF SPLINES	SPLINE DESCRIPTION	SPLINE O.D.	COUPLING O.D.	COUPLING LENGTH	PART NUMBER
9	16/32 DP 30° PA	.625	1 3/8	2	0332-00027
11	16/32 DP 30° PA	.750	1 3/8	2	0332-00066
13	16/32 DP 30° PA	.875	1 3/8	3	0332-00028
15	16/32 DP 30° PA	1.000	1 1/2	3	0332-00043
14	12/24 DP 30° PA	1.250	1 3/4	3	0332-00029
21	16/32 DP 30° PA	1.375	1 3/4	3	0332-00350
20	12/24 DP 30° PA	1.750	2 1/4	3 3/4	0332-00320
13	8/16 DP 30° PA	1.750	2 1/4	3 3/4	0332-00030
27	16/32 DP 30° PA	1.750	2 1/4	3	0332-00351



Hydraulic Reducer Bushings

MALE SPLINE	FEMALE SPLINE	A	B	C	PART NUMBER
1 3/4 - 13T 8/16 DP, 30° PA	5/8 - 9T 16/32 DP, 30° PA	1 3/8	1 7/32	1 5/16	23-01531
1 3/4 - 13T 8/16 DP, 30° PA	7/8 - 13T 16/32 DP, 30° PA	1 3/8	1 7/32	1 5/16	23-01532
1 3/4 - 13T 8/16 DP, 30° PA	1 1/4 - 14T 12/24 DP, 30° PA	1 7/32	N/A	N/A	23-01533
1 3/4 - 13T 8/16 DP, 30° PA	1 - 15T 16/32 DP, 30° PA	1 3/8	1 7/32	1 5/16	23-01558
1 1/4 - 14T 12/24 DP, 30° PA	.625 Round 5/32 x 5/64 KW	1 1/8	N/A	N/A	0223-02150
1 1/4 - 14T 12/24 DP, 30° PA	5/8 - 9T 16/32 DP, 30° PA	1 1/8	N/A	N/A	0223-02149
1 1/4 - 14T 12/24 DP, 30° PA	7/8 - 13T 16/32 DP, 30° PA	1 1/8	N/A	N/A	0223-02148

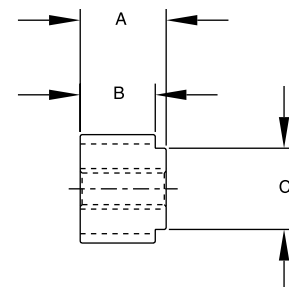

DOWNLOAD AVAILABLE CAD MODELS AT: WWW.HUBCITYINC.COM

Certified prints are available upon request

CALL: (605) 225-0360 • FAX: (605) 225-0567



FOR USER/OPERATOR SAFETY
SEE DETAILS PAGE R-11

Hub City Farm Products And Accessories

Non P.T.O. Products

Splined Shafts



SIZE	SPLINE	LENGTH (INCHES)	PART NUMBER
1	6	10	0332-00390
1 1/8	6	10	0332-00391
1 1/4	6	10	0332-00392
1 1/4	10	10	0332-00393
1 3/8	6	10	0332-00394
1 1/2	6	10	0332-00396
1 5/8	6	10	0332-00397
1 3/4	6	10	0332-00398

Extension Shafts



SPLINE	SPLINE	LENGTH (INCHES)	PART NUMBER
1 3/8-6	1 3/8-6	9	
1 1/2-6	1 1/2-6	9	

* Manufactured to order

Involute Splined Shafts



NO. OF SPLINES	SPLINE DESCRIPTION	SPLINE O.D.	SHAFT LENGTH	PART NUMBER
9	16/32 DP 30° PA	.625	6	0332-00023
13	16/32 DP 30° PA	.875	6	0332-00024
15	16/32 DP 30° PA	1	8	0332-00044
14	12/24 DP 30° PA	1.25	10	0332-00025
21	16/32 DP 30° PA	1.375	10	0332-00395
16	10/20 DP 30° PA	1.7	10	0332-00038*
13	8/16 DP 30° PA	1.75	10	0332-00026
27	16/32 DP 30° PA	1.75	10	0332-00399
34	20/40 DP 30° PA	1.750	10	0332-00415*
16	8/16 DP 30° PA	2.125	10	0332-00039

* Manufactured to order

DOWNLOAD AVAILABLE CAD MODELS AT: WWW.HUBCITYINC.COM

Certified prints are available upon request

EMAIL: hubsales@regalbeloit.com • www.hubcityinc.com



Hub City Farm Products And Accessories

Non P.T.O. Products



FOR USER/OPERATOR SAFETY
SEE DETAILS PAGE R-11

Round Bore Couplings

- Use to join two shafts
- Repair pulleys, gears, sprockets, etc.
- O.D. and I.D. concentricity not held to close limits
- If precision O.D. and I.D. concentricity is required, write for quotations
- Not drilled for setscrews



BORE SIZE	KEYWAY	O.D.	LENGTH(INCHES)	PART NUMBER
3/4	3/16	1 1/2	2 3/4	0332-00380
7/8	3/16	1 1/2	2 3/4	0332-00381
1	1/4	1 3/4	2 3/4	0332-00382
1 1/16	1/4	1 3/4	2 3/4	0332-00383*
1 1/8	1/4	2	3	0332-00384
1 3/16	1/4	2	3	0332-00385
1 1/4	1/4	2	3	0332-00386
1 5/16	5/16	2	3	0332-00387*
1 3/8	5/16	2 1/8	3	0332-00388
1 7/16	3/8	2 1/8	3	0332-00389
1 1/2	3/8	2 1/4	3	0332-00379

* Manufactured to order

Precision Splined Hubs

- Designed for hydraulic motors
- Made from low alloy, high carbon steel
- Close tolerance O.D. and I.D. concentricity permits accurate mounting of sheave or sprocket
- Precision also permits accurate chucking for additional mounting



NO. OF SPLINES	SPLINE DESCRIPTION		SPLINE O.D.	HUB O.D.	LENGTH(INCHES)	PART NUMBER
6	6B	Str. Side	1.000	2.001/2.000	1 3/4	0332-00031
18	1.25 Module	20° PA	.984	1.751/1.750	1 3/4	0332-00085*
9	16/32 DP	30° PA	.625	1.251/1.250	1 1/4	0332-00032
11	16/32 DP	30° PA	.750	1.501/1.500	1 1/2	0332-00071
13	16/32 DP	30° PA	.875	1.501/1.500	1 1/2	0332-00033
15	16/32 DP	30° PA	1.000	1.751/1.750	1 3/4	0332-00072
21	16/32 DP	30° PA	1.375	2.251/2.250	2 1/8	0332-00035
17	12/24 DP	30° PA	1.500	2.251/2.250	2 1/4	0332-00093
23	16/32 DP	30° PA	1.500	2.251/2.250	2 1/8	0332-00073
27	16/32 DP	30° PA	1.750	3.001/3.000	2 1/4	0332-00075
14	12/24 DP	30° PA	1.250	2.251/2.250	2	0332-00034
16	10/20 DP	30° PA	1.700	2.751/2.750	2 1/4	0332-00036
13	8/16 DP	30° PA	1.750	3.001/3.000	2 1/4	0332-00074
16	8/16 DP	30° PA	2.125	3.501/3.500	2 31/32	0332-00037

* Manufactured to order

DOWNLOAD AVAILABLE CAD MODELS AT: WWW.HUBCITYINC.COM

Certified prints are available upon request

CALL: (605) 225-0360 • FAX: (605) 225-0567



FOR USER/OPERATOR SAFETY
SEE DETAILS PAGE R-11

Hub City Farm Products And Accessories

Non P.T.O. Products

Utility Models - to 75 HP

- Same construction as Standard-Duty Tractor Models
- For those applications other than tractor P.T.O. shafts, where the driven shaft overruns the driver occasionally or where one shaft must override or idle part of the time.
- Operating Speed to 1000 RPM



Shipping Wgt. 6 lbs.

FEMALE SPLINE	MALE EXTENSION	PART NUMBER
1 1/4 Rd., 1/4 KW	1 1/4 Rd., 1/4 KW	0331-00615
Repair Kit		0337-00076

Installation and lubrication instructions enclosed with each coupler

Universal Models- to 75 HP

- Same construction as Standard-Duty Tractor Models
- Universal flange for mounting sheave or sprocket, has six 3/8" holes equally spaced on 4 1/4" Bolt Circle.
Flange O.D. 5" – Hub O.D. 2 3/4"
- Operating Speed to 1000 RPM



Shipping Wgt. 6 lbs.

FEMALE SLEEVE		PART NUMBER
I.D.	TYPE	
1 1/4	Round w/1/4 keyway	0331-00600
1 3/8	Round w/5/16 keyway	0331-00607
Repair Kit		0337-00082

Manufactured to order. Consult factory for price and delivery.

Special Over-Running Models

Send us details of your special requirements!
We can design and manufacture to your order.
Pictured to the right is a special unit with sprocket welded to outer housing.



DOWNLOAD AVAILABLE CAD MODELS AT: WWW.HUBCITYINC.COM

Certified prints are available upon request

EMAIL: hubsales@regalbeloit.com • www.hubcityinc.com



Hub City Farm Products And Accessories

Non P.T.O. Products



FOR USER/OPERATOR SAFETY
SEE DETAILS PAGE R-11

Stroke Control Segments for Hydraulic Cylinders

- Cast iron segments for durability
- Rigidly attached spring with contoured handle permits installation and removal with one hand
- Universal: each segment assembly fits all shaft sizes 1 through 1 ¾ inches
- Large area parallel compression face of segments distribute cylinder clamping load over a greater area of the cylinder head and cylinder rod ends clevis to minimize possible cylinder damage
- Attached spring reduces loss of segment halves
- Provides ¼ inch adjustments from 1 through 6 ½ inches
- Can be ordered by sets or segments



Segment Combinations

FOR STROKE REDUCTION (INCHES)	USE SEGMENT (INCHES)	FOR STROKE REDUCTION (INCHES)	USE SEGMENT (INCHES)
1	1	3 ½	1, 1, 1 ½
1 ¼	1 ¼	3 ¾	1, 1 ¼, 1 ½
1 ½	1 ½	4	1, 1 ¼, 1 ¾
1 ¾	1 ¾	4 ¼	1, 1 ½, 1 ¾
2	1, 1	4 ½	1 ¼, 1 ½, 1 ¾
2 ¼	1, 1 ¼	4 ¾	1, 1, 1 ¼, 1 ½
2 ½	1, 1 ½	5	1, 1, 1 ¼, 1 ¾
2 ¾	1, 1 ¾	5 ¼	1, 1, 1 ½, 1 ¾
3	1 ¼, 1 ¾	5 ½	1, 1 ¼, 1 ½, 1 ¾
3 ¼	1 ½, 1 ¾	6 ½	1, 1, 1 ¼, 1 ½, 1 ¾

SET OF 5 SEGMENTS	WEIGHT (LBS.)	PART NUMBER
	7.7	0339-80000
Set Includes:		
2 - 1 In. Segments	1.2	0339-80001
1 - 1 ¼ In. Segment	1.4	0339-80002
1 - 1 ½ In. Segment	1.8	0339-80003
1 - 1 ¾ In. Segment	2.1	0339-80004

DOWNLOAD AVAILABLE CAD MODELS AT: WWW.HUBCITYINC.COM

Certified prints are available upon request

CALL: (605) 225-0360 • FAX: (605) 225-0567



Hub City Farm Products And Accessories

Non P.T.O. Products

FOR USER/OPERATOR SAFETY
SEE DETAILS PAGE R-11

Over-Hung Load Adaptor for Orbit Motors

Specifically designed to direct connect with the orbit motor and provide substantially greater capacity for sprockets, sheaves, etc.

- Tapered Roller Bearings
- Grease Seals
- Lubricated for Life
- Two (2) Shaft Sizes
- Maximum O.H.L. Capacity

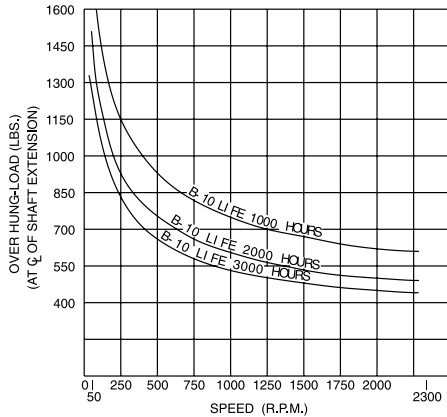

Dimensions for Char-Lynn Orbit Motors

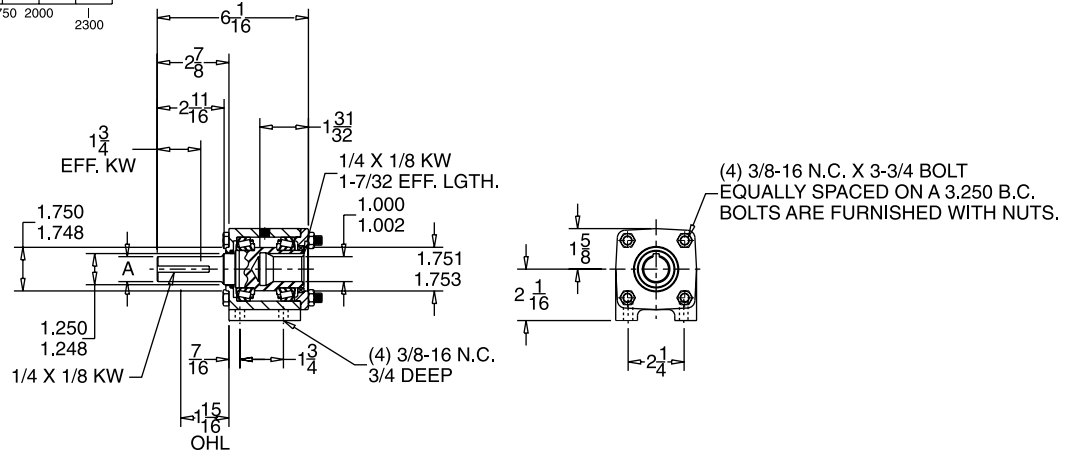

Dimensions for S.A.E. "A" 2-Hole Orbit Motors

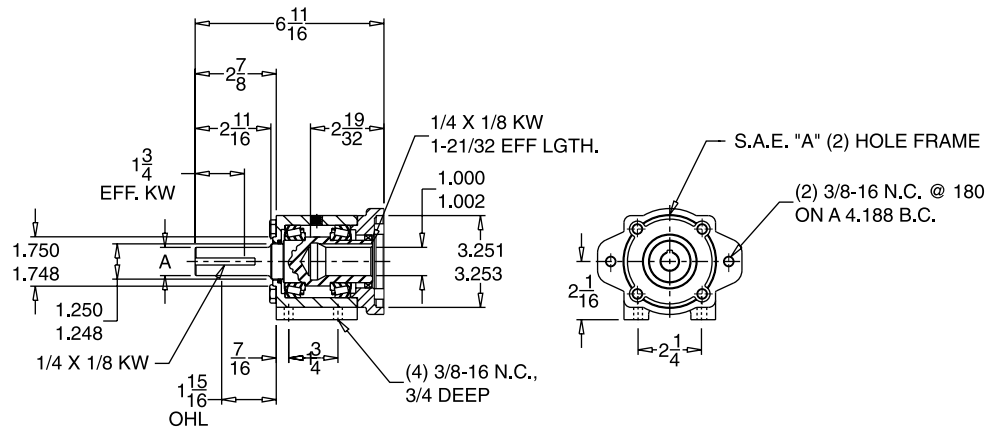

ITEM	SHAFT DIA. A	PART NUMBER	WGT. EACH
CHAR-LYNN MOTORS	1.000/.998	0334-00028	9 lbs.
CHAR-LYNN MOTORS	1.250/1.248	0334-00035	9 lbs.
S.A.E. 2-HOLE MOTORS	1.000/.998	0334-00042	11 lbs.
S.A.E. 2-HOLE MOTORS	1.250/1.248	0334-00043	11 lbs.

EXTREME OVER-HUNG LOADS WILL REQUIRE THE LARGER DIAMETER SHAFT

DOWNLOAD AVAILABLE CAD MODELS AT: WWW.HUBCITYINC.COM

Certified prints are available upon request

EMAIL: hubsales@regalbeloit.com • www.hubcityinc.com



Hub City Farm Products And Accessories

Model 330 Pump Drive



FOR USER/OPERATOR SAFETY
SEE DETAILS PAGE R-4

- Two standard ratios available
- Increases 540 or 1000 RPM tractor P.T.O. speed to 1825 RPM to facilitate use of a smaller, less expensive hydraulic pump
- Fits most standard SAE hydraulic pumps having SAE B or C mounting flange
- Easy installation and removal on most standard tractor P.T.O. shafts
- Torque arm bracket furnished as standard equipment
- Rugged cast aluminum housing
- All steel alloy gears
- High strength alloy shafts
- Off-the-shelf delivery
- Rated for pumps requiring up to 45 HP at 540 RPM and 65 HP at 1000 RPM



Weight 35 lbs.

With the new HUB CITY Series 330 Pump Drive, it is now possible to increase either 540 RPM or 1000 RPM tractor P.T.O. speed to 1825 RPM to permit use of a similar, less expensive hydraulic pump for your implements.

Two flange sizes are available: SAE B and C, for use with standard SAE pumps.

Also, both spline and round shafts are available in several sizes to suit your pump adaptation requirements.

DOWNLOAD AVAILABLE CAD MODELS AT: WWW.HUBCITYINC.COM

Certified prints are available upon request

CALL: (605) 225-0360 • FAX: (605) 225-0567



FOR USER/OPERATOR SAFETY
SEE DETAILS PAGE R-4

Hub City Farm Products And Accessories

Model 330 Pump Drive

Dimensions

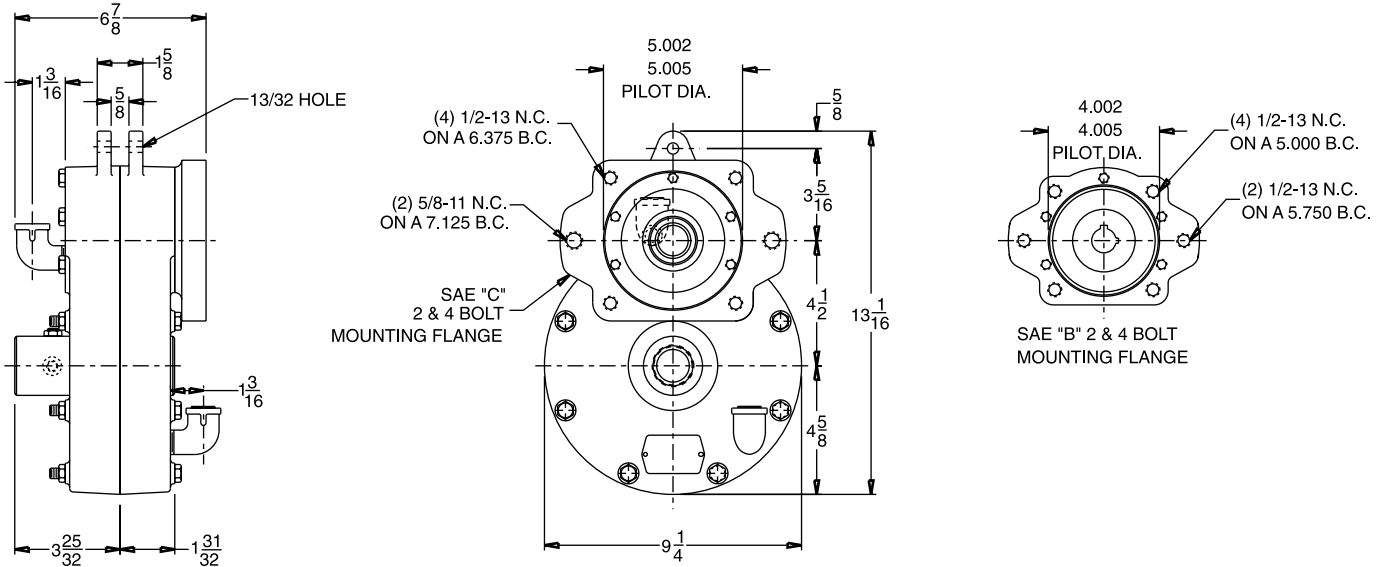

Specifications

PART NUMBER	SAE ADAPTOR	PUMP SLEEVE			OPERATING SPEED	
		NUMBER SPLINES	SPLINE/KEYWAY	SPLINE OR BORE I.D.	TRACTOR*	PUMP
0220-06110	B	Keyway	$\frac{3}{16} \times \frac{3}{32}$ KW $\frac{1}{4} \times \frac{1}{8}$ KW	.875	540 RPM	1825 RPM
0220-06104	B	Keyway	$\frac{1}{4} \times \frac{1}{8}$ KW	.875	1000 RPM	1825 RPM
0220-06109	B	13	16/32 DP 30° PA	.875	540 RPM	1825 RPM
0220-06103	B	13	16/32 DP 30° PA	.875	1000 RPM	1825 RPM
0220-06117	B	14	12/24 DP 30° PA	1.250	540 RPM	1825 RPM
0220-06112	C	Keyway	$\frac{5}{16} \times \frac{5}{32}$ KW	1.250	540 RPM	1825 RPM
0220-06106	C	Keyway	$\frac{5}{16} \times \frac{5}{32}$ KW	1.250	1000 RPM	1825 RPM
0220-06111	C	14	12/24 DP 30° PA	1.250	540 RPM	1825 RPM
0220-06105	C	14	12/24 DP 30° PA	1.250	1000 RPM	1825 RPM

* Input designed for 1 3/8 P.T.O. shaft only

540 RPM tractor 1 3/8 - 6 spline
1000 RPM tractor 1 3/8 - 21 spline

FOR LUBRICATION AND INSTALLATION
INSTRUCTIONS REFER TO SECTION S.

DOWNLOAD AVAILABLE CAD MODELS AT: WWW.HUBCITYINC.COM

Certified prints are available upon request

EMAIL: hubsales@regalbeloit.com • www.hubcityinc.com



Hub City Farm Products And Accessories

Shipping Weights And Index

PART NUMBER	WT.(LBS.)	PAGE	PART NUMBER	WT.(LBS.)	PAGE	PART NUMBER	WT.(LBS.)	PAGE
02-20-06103-330	35	R-19	03-32-00045	6.2	R-11	03-32-00392	2.8	R-13
02-20-06104-330	35	R-19	03-32-00057	1.5	R-8	03-32-00393	3	R-13
02-20-06105-330	35	R-19	03-32-00066	0.8	R-12	03-32-00394	3.5	R-13
02-20-06106-330	35	R-19	03-32-00070	3.5	R-6	03-32-00395	3.8	R-13
02-20-06109-330	35	R-19	03-32-00071	0.5	R-14	03-32-00396	4.3	R-13
02-20-06110-330	35	R-19	03-32-00072	0.5	R-14	03-32-00397	5.2	R-13
02-20-06111-330	35	R-19	03-32-00073	1.5	R-14	03-32-00398	5.8	R-13
02-20-06112-330	35	R-19	03-32-00074	1.5	R-14	03-32-00399	6.2	R-13
02-20-06117-330	35	R-19	03-32-00075	1.5	R-14	03-32-00400	2.3	R-6
02-23-02148-330	0.5	R-12	03-32-00084	1.5	R-6	03-32-00401	3.5	R-6
02-23-02149-330	0.5	R-12	03-32-00085	1.2	R-14	03-32-00403	0.5	R-8
02-23-02150-330	0.5	R-12	03-32-00086	0.5	R-7	03-32-00407	1.5	R-9
23-01531	0.5	R-12	03-32-00087	1.5	R-8	03-32-00408	1.5	R-9
23-01532	0.5	R-12	03-32-00092	2.5	R-8	03-32-00409	1.5	R-9
23-01533	0.5	R-12	03-32-00093	2	R-14	03-32-00410	1.3	R-9
23-01558	0.5	R-12	03-32-00094	6	R-6	03-32-00411	1.3	R-9
03-31-00010	7.5	R-10	03-32-00320	2	R-12	03-32-00412	1.5	R-9
03-31-00011	7.5	R-10	03-32-00336	1	R-12	03-32-00413	1.5	R-9
03-31-00012	7.5	R-10	03-32-00337	0.8	R-12	03-32-00415	1.5	R-13
03-31-00013	7.5	R-10	03-32-00338	0.8	R-12	03-32-00420	1.8	R-6
03-31-00600	6	R-15	03-32-00340	0.8	R-12	03-32-00430	1.8	R-8
03-31-00607	6	R-15	03-32-00341	0.8	R-12	03-32-00431	1.8	R-8
03-31-00615	6	R-15	03-32-00342	1.5	R-12	03-32-00432	1.8	R-8
03-31-00660	6	R-10	03-32-00344	0.8	R-12	03-32-00433	1.8	R-8
03-31-00670	6	R-10	03-32-00345	1	R-12	03-32-00607	1.5	R-9
03-31-00680	6	R-10	03-32-00346	1.8	R-12	03-32-00608	1.5	R-9
03-31-00690	6	R-10	03-32-00347	1.3	R-12	03-32-00610	1.3	R-9
03-32-00001	6	R-6	03-32-00348	1.3	R-12	03-32-00611	1.5	R-9
03-32-00002	6	R-6	03-32-00349	1.3	R-12	03-32-00612	1.5	R-9
03-32-00004	6	R-6	03-32-00350	1	R-12	03-32-01345	1.3	R-9
03-32-00005	6	R-6	03-32-00351	1.5	R-12	03-32-01350	1.3	R-9
03-32-00010	2.3	R-7	03-32-00352	0.3	R-8	03-32-01354	1.5	R-8
03-32-00011	2	R-9	03-32-00355	0.5	R-8	03-32-01373	2.5	R-7
03-32-00012	2	R-9	03-32-00356	3.3	R-13	03-32-01375	2.5	R-8
03-32-00013	2	R-7	03-32-00357	3	R-13	03-32-01476	7	R-7
03-32-00014	2	R-9	03-32-00358	1.5	R-9	03-32-01477	7	R-7
03-32-00015	2	R-7	03-32-00359	2.3	R-9	03-32-01490	7	R-7
03-32-00016	1.8	R-9	03-32-00360	1	R-11	03-32-01491	7	R-7
03-32-00017	1.8	R-9	03-32-00362	1.3	R-11	03-32-02121	2.5	R-7
03-32-00018	0.8	R-8	03-32-00363	0.3	R-8	03-32-03531	1.8	R-6
03-32-00019	2.3	R-9	03-32-00364	1.5	R-11	03-34-00028	9	R-17
03-32-00023	0.5	R-13	03-32-00365	1	R-12	03-34-00035	9	R-17
03-32-00024	0.8	R-13	03-32-00367	1.3	R-12	03-34-00042	11	R-17
03-32-00025	3	R-13	03-32-00371	2.5	R-6	03-34-00043	11	R-17
03-32-00026	5.8	R-13	03-32-00373	2.8	R-6	0335-90120	0.5	R-8
03-32-00027	0.8	R-12	03-32-00376	1.8	R-8	0336-00182	0.5	R-8
03-32-00028	0.8	R-12	03-32-00377	1.8	R-6	03-37-00076	0.8	R-10&R-15
03-32-00029	1	R-12	03-32-00378	1.8	R-6	03-37-00082	0.8	R-15
03-32-00030	2	R-12	03-32-00379	1.8	R-14	03-37-00126	0.5	R-10
03-32-00031	1.2	R-14	03-32-00380	1	R-14	03-39-80000	7.7	R-16
03-32-00032	0.3	R-14	03-32-00381	1	R-14	03-39-80001	1.2	R-16
03-32-00033	0.5	R-14	03-32-00382	1.3	R-14	03-39-80002	1.4	R-16
03-32-00034	1.5	R-14	03-32-00383	1.3	R-14	03-39-80003	1.8	R-16
03-32-00035	2	R-14	03-32-00384	1.8	R-14	03-39-80004	2	R-16
03-32-00036	2.5	R-14	03-32-00385	1.8	R-14	8-58-00-01-009	2	S-7
03-32-00039	9	R-13	03-32-00388	1.8	R-14	8-58-00-01-031	2	S-7
03-32-00039	9	R-13	03-32-00389	1.5	R-14			
03-32-00043	0.8	R-12	03-32-00390	1.3	R-13			
03-32-00044	1.6	R-13	03-32-00391	2.3	R-13			

DOWNLOAD AVAILABLE CAD MODELS AT: WWW.HUBCITYINC.COM

Certified prints are available upon request

CALL: (605) 225-0360 • FAX: (605) 225-0567

Hub City PowerTorque® Shaft Mount Reducers

PowerTorque® Features and Description.....	G-2
Nomenclature.....	G-4
Selection Instructions	G-5
Selection By Horsepower.....	G-7
Mechanical Ratings.....	G-12
Dimensions	G-14
Accessories.....	G-15
Screw Conveyor Accessories	G-22

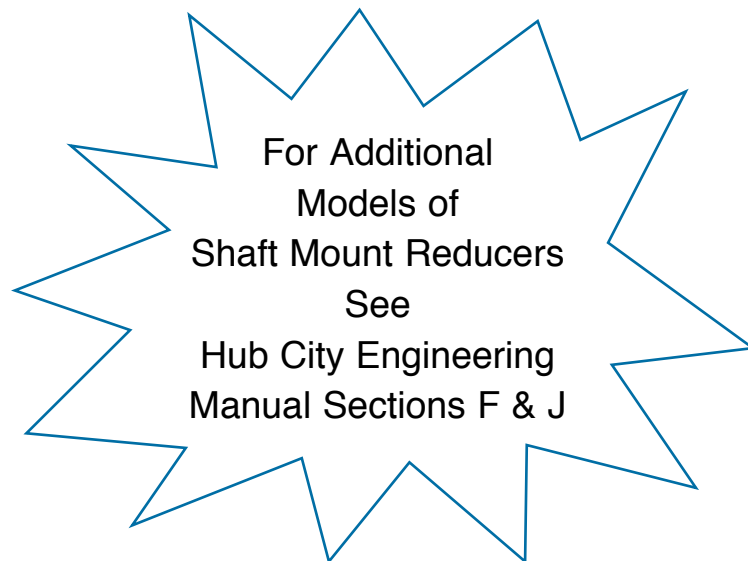

DOWNLOAD AVAILABLE CAD MODELS AT: WWW.HUBCITYINC.COM

Certified prints are available upon request

EMAIL: hubsales@regalbeloit.com • www.hubcityinc.com

Hub City PowerTorque® Shaft Mount Reducers

Ten models available from 1/4 HP through 200 HP capacity

Manufacturing Quality

Manufactured to the highest quality standards in the industry, assembled using precision manufactured components made from top quality materials

Designed for the toughest applications in the industry

Housings

High strength ductile iron housings, rather than cast iron material

Gearing

High Efficiency gearing is manufactured from 8620 steel, case carburized, hardened to RC62, and precision ground, AGMA Class 11, rather than crowned and shaved

Output Bores

Standard bores range from 1-7/16" through 5-7/16"

Ratios

Ratios from 9:1, 15:1 and 25:1

Shafts

Input shafts are machined from high strength alloy steel and hardened for premium load carrying capability

Bearings

Tapered roller bearings are selected for optimum life and load carrying capability

Seals

Double lip seals feature metal reinforcement and ride on precision ground shaft surfaces for longevity

98.5%
Efficiency
per Gear Stage!



Lubrication

Ample lubrication is provided by abundant splash from the large oil sump

Interchangeability

Dimensionally and mechanically interchangeable with most major brands

Warranty

Backed by an 18 month warranty for assured dependable longevity while providing trouble free service

DOWNLOAD AVAILABLE CAD MODELS AT: WWW.HUBCITYINC.COM

Certified prints are available upon request

CALL: (605) 225-0360 • FAX: (605) 225-0567

Hub City PowerTorque® Shaft Mount Reducers

The Hub City Advantage

Hub City PowerTorque® Accessories complete the drive package by providing tapered bushings, backstops, and motor mounts. Screw conveyor drive accessories include adapter flanges and drive shafts.



Tapered Bushing Kits

- Flanged bushing mount
- Removal screws allow for easy demounting
- Ductile iron material for shock resistance
- Clamp fit, no setscrews
- Split design eliminates seizing problems



Backstop Assemblies

- Quick installation on input shaft
- Internally installed, sealed from contamination
- Lubricated by internal gear lubricant
- Designed to operate in either direction



Motor Mounts

- All-Steel construction for rigidity
- Compact design eliminates need for motor base
- Top plate adjusts for easy tensioning of drive belt
- Mounting holes provided match NEMA standards



Screw Conveyor Adapter Flanges

- Conform to CEMA standards
- Bolt-on design allows easy mounting
- Open center for contaminate dropout



Screw Conveyor Drive Shafts

- Machined from high strength alloy steel
- Conform to CEMA dimensional standards
- Easy installation into standard hollow bore



Belt Guards

- All-Steel construction
- Adjustable to fit a wide range of sheaves and motor frames
- Designed for easy installation, no drilling required

DOWNLOAD AVAILABLE CAD MODELS AT: WWW.HUBCITYINC.COM

Certified prints are available upon request

EMAIL: hubsales@regalbeloit.com • www.hubcityinc.com

Hub City PowerTorque® Shaft Mount Reducers

Description

Descriptions For Ordering Shaft Mount Reducers

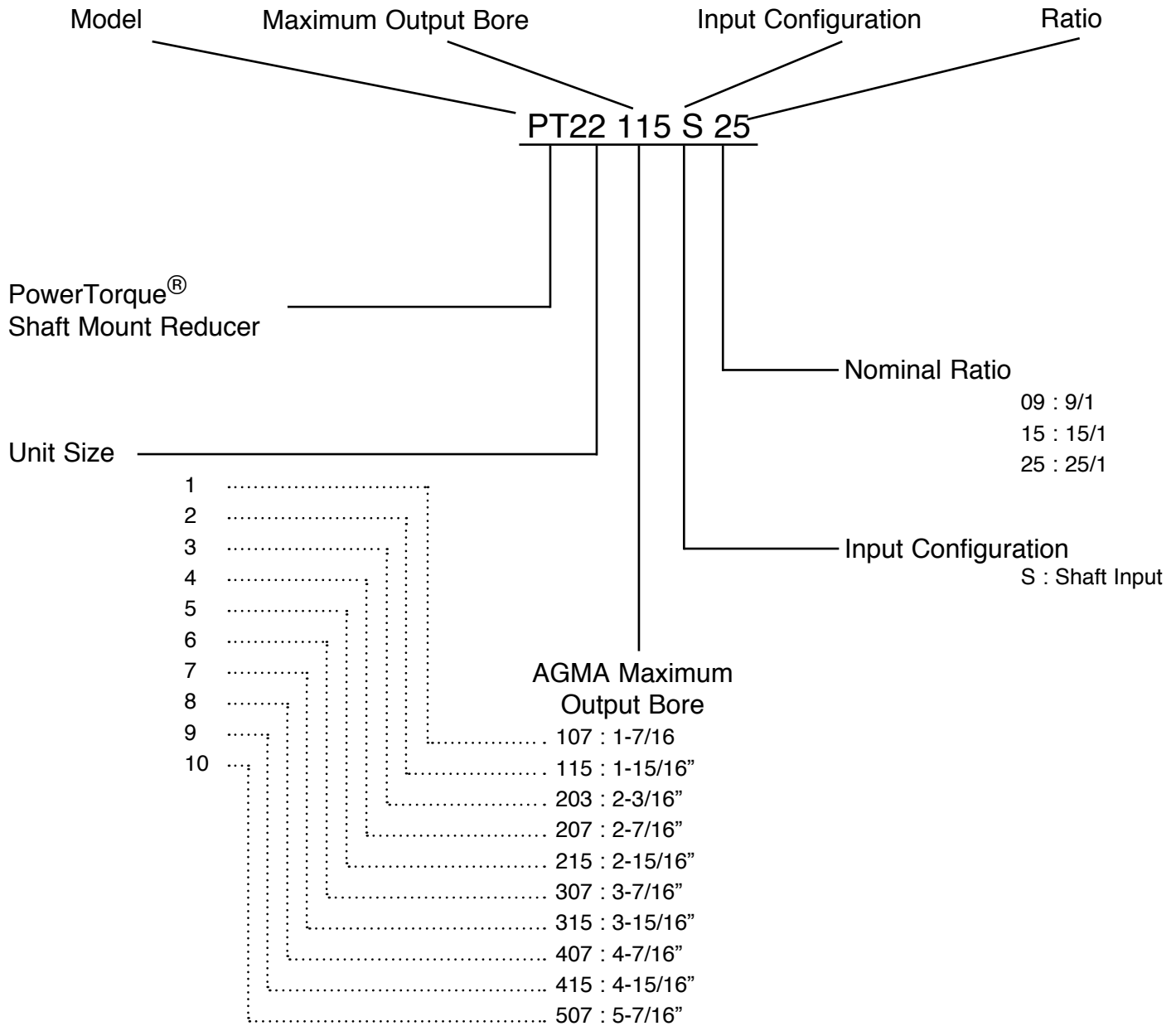

Part Number Prefixes

- 0270-XXXXX Standard Assembly
- 0271-XXXXX Modified Assembly
- 0273-XXXXX Standard Service Part
- 0275-XXXXX Modified Service Part
- 0279-XXXXX Accessory Kit

DOWNLOAD AVAILABLE CAD MODELS AT: WWW.HUBCITYINC.COM

Certified prints are available upon request

CALL: (605) 225-0360 • FAX: (605) 225-0567

Hub City PowerTorque® Shaft Mount Reducers

Selection Procedure

Hub City PowerTorque® reducers are selected on the basis of input horsepower and output speed. There are ten double reduction PowerTorque® Models available in nominal ratios of 9:1, 15:1, and 25:1 with output speeds to

200 RPM and ratings up to 200 HP. The selection tables have been established so that once the horsepower and driven speed are known the appropriate model can be readily selected.

AGMA Load Classification

Determine the AGMA Load Classification Number for your application from the AGMA tables in Engineering Manual. In mechanical drives the presence of shock loads will usually reduce the life of the reducers. In order to provide optimum service in heavily loaded applications, it is necessary to use load classes to adjust the reducer ratings for the stresses created by different types of loads. The

Numbers

AGMA Load Classes provide for a momentary or starting load of 2.0 times for Class I, 2.8 for Class II, and 4.0 for Class III. Refer to the AGMA tables in Engineering Manual. for further information and cautions on the selection of proper service factors

LOAD CLASS (S.F.)	UP TO 3 HRS. TOTAL OPERATION PER DAY	3 TO 10 HRS. TOTAL OPERATION PER DAY	OVER 10 HRS. TOTAL OPERATION PER DAY
I (1.0)	Moderate Shock Load	Uniform Load	
II (1.4)	Heavy Shock Load	Moderate Shock Load	Uniform Load
III (2.0)		Heavy Shock Load	Moderate Shock Load

Select Reducer Size and Ratio

Refer to the applicable Selection Table for the AGMA Load Class I, II, or III on pages G-7 to

G-11. Locate the required HP and Output Speed, and read across to find the reducer size.

Select Tapered Bushings

Compare the hollow shaft bore with the diameter of the driven shaft. If the driven shaft is smaller than the maximum bore for the reducer selected, select the proper tapered bushings from the table on page G-15 to adapt

the hollow shaft bore to the diameter of the driven shaft. If the driven shaft diameter is larger than the maximum bore for the reducer selected, it is necessary to either turn down the driven shaft, or select a larger reducer.

Select Sheave Ratio

To determine the V-belt sheave ratio required to produce the desired output speed, use the following formula: sheave ratio = exact motor RPM / (output RPM X exact gear ratio).

Refer to the catalog of your chosen V-belt supplier to select the most economical V-belt drive to transmit the HP at the required output speed by following the selection procedure outlined in the V-belt catalog.

Hub City PowerTorque® Shaft Mount Reducers

Selection Procedure



Refer to the Minimum Diameter for Driven Sheaves listed in the Selection Tables to be certain that your driven sheave selection is larger than the minimum diameter recommended for the reducer selected.

Accessories:

Select Motor Mount

Select the motor frame and motor mount size from the tables on page G-16 to G-19 based on the reducer size.

Select Belt Guards

Select belt guards from the tables on pages G-20 and G-21 based on the reducer size.

Select Screw Conveyor Drive Shaft and Adapter

Select the CEMA adapter and drive shaft from the tables on page G-22 based on the reducer size.

Select Backstop

Optional backstops are available for applications that require the prevention of reverse rotation. Select the backstop from the table on page G-15 based on the reducer size. Backstops are installed on the high speed pinion shaft by removing the cover on the back side (opposite side from the input shaft extension) of the housing.



Backstops are not recommended for applications involving energy absorption and shock or torque loads in excess of reducer ratings or on applications such as chair lifts, amusement rides, etc. where the safety of a person or property is dependent on their function. On such applications, other safety devices should be provided.

Backstops are designed to prevent rotation not more than five times in an 8 hour period with a minimum of one minute in the over-running direction between each engagement. If reversing operation is more frequent or over-running time is less, the application should be referred to the factory.



Lubricants with extreme pressure (EP) additives should not be used in units with backstops installed.

Other Accessories Supplied Upon Request:

- Cooling Fans
- Mounting Brackets
- Auxiliary Seal Kits

Note: A torque-arm assembly is supplied with all shaft mount reducers.

For Lubrication and Installation Instructions Refer to Section S.

Hub City PowerTorque® Shaft Mount Reducers

Selection By Input Horsepower

Class I Service

HP	OUTPUT RPM	REDUCER SELECTION	MINIMUM SHEAVE DIA.
0.25	4 ~ 70	PT21107-25 PT21107-15	3.0
	71 ~ 85	PT21107-25 PT21107-15	3.0
	86 ~ 115	PT21107-15 PT21107-09	3.0/4.0
	116 ~ 140	PT21107-15 PT21107-09	3.0/4.0
	141 ~ 200	PT21107-09	4.0
0.33	5 ~ 70	PT21107-25 PT21107-15	3.0
	71 ~ 85	PT21107-25 PT21107-15	3.0
	86 ~ 115	PT21107-15 PT21107-09	3.0/4.0
	116 ~ 140	PT21107-15 PT21107-09	3.0/4.0
	141 ~ 200	PT21107-09	4.0
0.50	4 ~ 6	PT22115-25	3.0
	7 ~ 70	PT21107-25 PT21107-15	3.0
	71 ~ 85	PT21107-25 PT21107-15	3.0
	86 ~ 115	PT21107-15 PT21107-09	3.0/4.0
	116 ~ 140	PT21107-15 PT21107-09	3.0/4.0
0.75	4 ~ 5	PT23203-25	4.0
	6 ~ 10	PT22115-25	3.0
	11 ~ 70	PT21107-25 PT21107-15	3.0
	71 ~ 85	PT21107-25 PT21107-15	3.0
	86 ~ 115	PT21107-15 PT21107-09	3.0/4.0
1	4 ~ 5	PT24207-25	4.6
	6 ~ 7	PT23203-25	4.0
	8 ~ 15	PT22115-25	3.0
	16 ~ 70	PT21107-25 PT21107-15	3.0
	71 ~ 85	PT21107-25 PT21107-15	3.0
1.5	4	PT25215-25	5.4
	5 ~ 7	PT24207-25	4.6
	8 ~ 12	PT23203-25	4.0
	13 ~ 23	PT22115-25	3.0
	24 ~ 70	PT21107-25 PT21107-15	3.0
2	4 ~ 6	PT25215-25	5.4
	7 ~ 10	PT24207-25	4.6
	11 ~ 17	PT23203-25	4.0
	18 ~ 32	PT22115-25 PT22115-15	3.0
	33 ~ 70	PT21107-25 PT21107-15	3.0
3	4 ~ 5	PT26307-25	6.2
	6 ~ 10	PT25215-25	5.4
	11 ~ 15	PT24207-25	4.6
	16 ~ 26	PT23203-25	4.0
	27 ~ 51	PT22115-25 PT22115-15	3.0
5	5 ~ 6	PT27315-25	6.2

HP	OUTPUT RPM	REDUCER SELECTION	MINIMUM SHEAVE DIA.
5 (cont.)	7 ~ 9	PT26307-25	6.2
	10 ~ 17	PT25215-25	5.4
	18 ~ 26	PT24207-25 PT24207-15	4.6
	27 ~ 46	PT23203-25 PT23203-15	4.0
	47 ~ 70	PT22115-25 PT22115-15	3.0
	71 ~ 85	PT22115-25 PT22115-15	3.0
	86 ~ 92	PT21107-09 PT22115-15	4.0/3.0
	93 ~ 115	PT21107-15 PT21107-09	3.0/4.0
	116 ~ 140	PT21107-15 PT21107-09	3.0/4.0
	141 ~ 200	PT21107-09	4.0
7.5	4 ~ 6	PT28407-25	6.2
	7 ~ 9	PT27315-25	6.2
	10 ~ 15	PT26307-25	6.2
	16 ~ 26	PT25215-25	5.4
	27 ~ 40	PT24207-25 PT24207-15	4.6
	41 ~ 70	PT23203-25 PT23203-15	4.0
	71 ~ 74	PT23203-25 PT23203-15	4.0
	75 ~ 85	PT22115-25 PT22115-15	3.0
	86 ~ 95	PT22115-15	3.0
	96 ~ 140	PT22115-15	3.0
10	4 ~ 6	PT29415-25	8.0
	6 ~ 8	PT28407-25	6.2
	9 ~ 12	PT27315-25	6.2
	13 ~ 20	PT26307-25	6.2
	21 ~ 36	PT25215-25 PT25215-15	5.4
	37 ~ 56	PT24207-25 PT24207-15	4.6
	57 ~ 70	PT23203-25 PT23203-15	4.0
	71 ~ 85	PT23203-25 PT23203-15	4.0
	86 ~ 103	PT23203-15 PT23203-09	4.0/5.0
	104 ~ 115	PT22115-15	3.0
15	4 ~ 6	PT210507-25	8.5
	7 ~ 8	PT29415-25	8.0
	9 ~ 13	PT28407-25	6.2
	14 ~ 19	PT27315-25	6.2
	20 ~ 32	PT26307-25 PT26307-15	6.2
	33 ~ 56	PT25215-25 PT25215-15	5.4
	57 ~ 70	PT24207-25 PT24207-15	4.6
	71 ~ 85	PT24207-25 PT24207-15	4.6
	86 ~ 93	PT24207-15 PT24207-09	4.6/6.5
	94 ~ 115	PT23203-15 PT23203-09*	4.0/5.0
20	4 ~ 6	PT210507-25	8.5
	7 ~ 8	PT29415-25	8.0
	9 ~ 12	PT28407-25	6.2
	13 ~ 18	PT27315-25 PT27315-15	6.2
	19 ~ 26	PT26307-25 PT26307-15	6.2
	27 ~ 45	PT25215-25 PT25215-15	5.4
	46 ~ 70	PT25215-25 PT25215-15	5.4
	71 ~ 78	PT25215-25 PT25215-15	5.4
	79 ~ 85	PT24207-25 PT24207-15	4.6
	86 ~ 115	PT24207-15 PT24207-09*	4.6/6.5
25	4 ~ 6	PT210507-25	8.5
	7 ~ 8	PT29415-25	8.0
	9 ~ 12	PT28407-25	6.2
	13 ~ 18	PT27315-25 PT27315-15	6.2
	19 ~ 26	PT26307-25 PT26307-15	6.2
	27 ~ 45	PT25215-25 PT25215-15	5.4
	46 ~ 70	PT25215-25 PT25215-15	5.4
	71 ~ 78	PT25215-25 PT25215-15	5.4
	79 ~ 85	PT24207-25 PT24207-15	4.6
	86 ~ 115	PT24207-15 PT24207-09*	4.6/6.5

*Additional Cooling Provisions May Be Required. consult Factory with Application Details.

DOWNLOAD AVAILABLE CAD MODELS AT: WWW.HUBCITYINC.COM

Certified prints are available upon request

EMAIL: hubsales@regalbeloit.com • www.hubcityinc.com



PowerTorque® Shaft Mount Reducers



Hub City PowerTorque® Shaft Mount Reducers

Selection By Input Horsepower

Class I Service cont.

HP	OUTPUT RPM	REDUCER SELECTION	MINIMUM SHEAVE DIA.	
25 (cont.)	16 ~ 23	PT28407-25	6.2	
	24 ~ 33	PT27315-25 PT27315-15	6.2	
	34 ~ 59	PT26307-25 PT26307-15	6.2	
	60 ~ 70	PT25215-25* PT25215-15*	5.4	
	71 ~ 80	PT25215-25* PT25215-15*	5.4	
	81 ~ 101	PT25215-15* PT25215-09*	5.4	
	102 ~ 132	PT24207-15* PT24207-09*	4.6/6.5	
	133 ~ 140	PT24207-15* PT24207-09*	4.6/6.5	
	141 ~ 163	PT24207-09*	6.5	
164 ~ 200	PT24207-09*	6.5		
30	10 ~ 13	PT210507-25	8.5	
	14 ~ 19	PT29415-25	8.0	
	20 ~ 28	PT28407-25 PT28407-15	6.2	
	29 ~ 41	PT27315-25 PT27315-15	6.2	
	42 ~ 70	PT26307-25 PT26307-15	6.2	
	71 ~ 75	PT26307-25 PT26307-15	6.2	
	76 ~ 115	PT25215-15* PT25215-09*	5.4/7.0	
	116 ~ 125	PT25215-15* PT25215-09*	5.4/7.0	
	126 ~ 131	PT24207-09*	6.5	
132 ~ 200	PT24207-09*	6.5		
40	13 ~ 18	PT210507-25	8.5	
	19 ~ 25	PT29415-25 PT29415-15	8.0	
	26 ~ 38	PT28407-25 PT28407-15	6.2	
	39 ~ 57	PT27315-25 PT27315-15	6.2	
	58 ~ 70	PT26307-25 PT26307-15	6.2	
	71 ~ 81	PT26307-25* PT26307-15*	6.2	
	82 ~ 114	PT26307-15* PT26307-09*	6.2/7.0	
	115 ~ 125	PT25215-15* PT25215-09*	5.4/7.0	
	126 ~ 200	PT25215-09*	7.0	
50	16 ~ 22	PT210507-25	8.5	
	23 ~ 32	PT29415-25 PT29415-15	8.0	
	33 ~ 49	PT28407-25 PT28407-15	6.2	
	50 ~ 70	PT27315-25 PT27315-15	6.2	
	71 ~ 74	PT27315-25 PT27315-15	6.2	
	75 ~ 125	PT26307-15* PT27315-09*	6.2/7.0	
	126 ~ 163	PT27315-09*	7.0	
	164 ~ 200	PT26307-09*	7.0	
	60	19 ~ 27	PT210507-25	8.5
28 ~ 39		PT29415-25 PT29415-15	8.0	
40 ~ 60		PT28407-25 PT28407-15	6.2	
61 ~ 70		PT27315-25* PT27315-15*	6.2	
71 ~ 120		PT27315-15* PT27315-09*	6.2/7.0	
121 ~ 131		PT27315-09*	7.0	
132 ~ 200		PT27315-09*	7.0	
75		24 ~ 34	PT210507-25	8.5
		35 ~ 50	PT29415-25 PT29415-15	8.0
	51 ~ 70	PT28407-25 PT28407-15	6.2	
	71 ~ 78	PT28407-15*	6.2	
	79 ~ 120	PT27315-15* PT27315-09*	6.2/7.0	
	121 ~ 200	PT27315-09*	7.0	
100	32 ~ 46	PT210507-25	8.5	
	47 ~ 69	PT29415-25* PT29415-15*	8.0	
	70 ~ 120	PT28407-15*	6.2	
	121 ~ 123	PT27315-09*	7.0	
	124 ~ 200	PT27315-09*	7.0	
125	41 ~ 59	PT210507-25	8.5	
	60 ~ 70	PT29415-25* PT29415-15*	8.0	
	71 ~ 90	PT29415-15*	8.0	
	91 ~ 123	PT28407-15*	6.2	
150	50 ~ 70	PT210507-25	8.5	
	71 ~ 78	PT210507-25*	8.5	
	79 ~ 120	PT29415-15	8.0	

Class II Service

HP	OUTPUT RPM	REDUCER SELECTION	MINIMUM SHEAVE DIA.
0.25	5 ~ 70	PT21107-25 PT21107-15	3.0
	71 ~ 85	PT21107-25 PT21107-15	3.0
	86 ~ 115	PT21107-15 PT21107-09	3.0/4.0
	116 ~ 140	PT21107-15 PT21107-09	3.0/4.0
	141 ~ 200	PT21107-09	4.0
0.33	4 ~ 6	PT22115-25	3.0
	7 ~ 70	PT21107-25 PT21107-15	3.0
	71 ~ 85	PT21107-25 PT21107-15	3.0
	86 ~ 115	PT21107-15 PT21107-09	3.0/4.0
	116 ~ 140	PT21107-15 PT21107-09	3.0/4.0
0.5	141 ~ 200	PT21107-09	4.0
	4 ~ 5	PT23203-25	4.0
	6 ~ 9	PT22115-25	3.0
	10 ~ 70	PT21107-25 PT21107-15	3.0
	71 ~ 85	PT21107-25 PT21107-15	3.0
	86 ~ 115	PT21107-15 PT21107-09	3.0/4.0
	116 ~ 140	PT21107-15 PT21107-09	3.0/4.0
	141 ~ 200	PT21107-09	4.0
	0.75	4 ~ 5	PT24207-25
6 ~ 8		PT23203-25	4.0
9 ~ 16		PT22115-25	3.0
17 ~ 70		PT21107-25 PT21107-15	3.0
71 ~ 85		PT21107-25 PT21107-15	3.0
86 ~ 115		PT21107-15 PT21107-09	3.0/4.0
1	116 ~ 140	PT21107-15 PT21107-09	3.0/4.0
	141 ~ 200	PT21107-09	4.0
	5 ~ 7	PT24207-25	4.6
	8 ~ 11	PT23203-25	4.0
	12 ~ 22	PT22115-25	3.0
	23 ~ 70	PT21107-25 PT21107-15	3.0
	71 ~ 85	PT21107-25 PT21107-15	3.0
	86 ~ 115	PT21107-15 PT21107-09	3.0/4.0
	116 ~ 140	PT21107-15 PT21107-09	3.0/4.0
1.5	141 ~ 200	PT21107-09	4.0
	5 ~ 6	PT25215-25	5.4
	7 ~ 11	PT24207-25	4.6
	12 ~ 18	PT23203-25	4.0
	19 ~ 34	PT22115-25 PT22115-15	3.0
	35 ~ 70	PT21107-25 PT21107-15	3.0
	71 ~ 85	PT21107-25 PT21107-15	3.0
	86 ~ 115	PT21107-15 PT21107-09	3.0/4.0
	116 ~ 140	PT21107-15 PT21107-09	3.0/4.0
2	141 ~ 200	PT21107-09	4.0
	4 ~ 5	PT26307-25	6.2
	6 ~ 9	PT25215-25	5.4
	10 ~ 14	PT24207-25	4.6
	15 ~ 24	PT23203-25 PT23203-15	4.0
	25 ~ 47	PT22115-25 PT22115-15	3.0
	48 ~ 70	PT21107-25 PT21107-15	3.0
	71 ~ 85	PT21107-25 PT21107-15	3.0
	86 ~ 115	PT21107-15 PT21107-09	3.0/4.0
	116 ~ 140	PT21107-15 PT21107-09	3.0/4.0
3	141 ~ 200	PT21107-09	4.0
	4 ~ 5	PT27315-25	6.2
	6 ~ 8	PT26307-25	6.2
	9 ~ 14	PT25215-25	5.4
	15 ~ 22	PT24207-25 PT24207-15	4.6
	23 ~ 38	PT23203-25 PT23203-15	4.0
	39 ~ 70	PT22115-25 PT22115-15	3.0
	71 ~ 75	PT22115-25 PT22115-15	3.0
	76 ~ 85	PT21107-25 PT21107-15	3.0
	86 ~ 115	PT21107-15 PT21107-09	3.0/4.0

*Additional Cooling Provisions May Be Required. consult Factory with Application Details.

DOWNLOAD AVAILABLE CAD MODELS AT: WWW.HUBCITYINC.COM

Certified prints are available upon request

CALL: (605) 225-0360 • FAX: (605) 225-0567

Hub City PowerTorque® Shaft Mount Reducers

Selection By Input Horsepower

Class II Service cont.

HP	OUTPUT RPM	REDUCER SELECTION	MINIMUM SHEAVE DIA.	
3 (cont.)	116 ~ 140	PT21107-15 PT21107-09	3.0/4.0	
	141 ~ 200	PT21107-09	4.0	
5	4 ~ 6	PT28407-25	6.2	
	7 ~ 8	PT27315-25	6.2	
	9 ~ 14	PT26307-25	6.2	
	15 ~ 24	PT25215-25	5.4	
	25 ~ 37	PT24207-25 PT24207-15	4.6	
	38 ~ 69	PT23203-25 PT23203-15	4.0	
	70 ~ 85	PT22115-25 PT22115-15	3.0	
	86 ~ 89	PT22115-15 PT22115-09	3.0/5.0	
	90 ~ 136	PT22115-15 PT22115-09	3.0/5.0	
	137 ~ 140	PT21107-15 PT22115-09	3.0/5.0	
	141 ~ 200	PT21107-09	4.0	
7.5	5	PT29415-25	8.0	
	6 ~ 9	PT28407-25	6.2	
	10 ~ 13	PT27315-25	6.2	
	14 ~ 21	PT26307-25	6.2	
	22 ~ 38	PT25215-25 PT25215-15	5.4	
	39 ~ 59	PT24207-25 PT24207-15	4.6	
	60 ~ 70	PT23203-25 PT23203-15	4.0	
	71 ~ 85	PT23203-25 PT23203-15	4.0	
	86 ~ 110	PT23203-15 PT23203-09	4.0/5.0	
	111 ~ 122	PT22115-15 PT23203-09	3.0/5.0	
	123 ~ 140	PT22115-15 PT23203-09	3.0/5.0	
	141 ~ 183	PT23203-09	5.0	
	184 ~ 200	PT22115-09	5.0	
	10	5	PT210507-25	8.5
6 ~ 7		PT29415-25	8.0	
8 ~ 12		PT28407-25	6.2	
13 ~ 18		PT27315-25	6.2	
19 ~ 29		PT26307-25 PT26307-15	6.2	
30 ~ 52		PT25215-25 PT25215-15	5.4	
53 ~ 70		PT24207-25 PT24207-15	4.6	
71 ~ 84		PT24207-25 PT24207-15	4.6	
85 ~ 130		PT23203-15 PT23203-09	4.0/5.0	
131 ~ 140		PT23203-15 PT23203-09	4.0/5.0	
141 ~ 200		PT23203-09	5.0	
15		7 ~ 9	PT210507-25	8.5
	10 ~ 12	PT29415-25	8.0	
	13 ~ 19	PT28407-25	6.2	
	20 ~ 27	PT27315-25	6.2	
	28 ~ 47	PT26307-25 PT26307-15	6.2	
	48 ~ 70	PT25215-25 PT25215-15	5.4	
	71 ~ 82	PT25215-25 PT25215-15	5.4	
	83 ~ 117	PT24207-15 PT24207-09	4.6/6.5	
	118 ~ 140	PT24207-15 PT24207-09	4.6/6.5	
	141 ~ 150	PT24207-09	6.5	
	151 ~ 200	PT23203-09*	5.0	
	20	9 ~ 12	PT210507-25	8.5
		13 ~ 17	PT29415-25	8.0
18 ~ 26		PT28407-25	6.2	
27 ~ 38		PT27315-25 PT27315-15	6.2	
39 ~ 68		PT26307-25 PT26307-15	6.2	
69 ~ 80		PT25215-25 PT25215-15	5.4	
81 ~ 89		PT25215-15	5.4	
91 ~ 117		PT25215-15* PT25215-09*	5.4/7.0	
118 ~ 125		PT24207-15* PT24207-09*	4.6/6.5	
126 ~ 200		PT24207-09*	6.5	

HP	OUTPUT RPM	REDUCER SELECTION	MINIMUM SHEAVE DIA.
25	11 ~ 15	PT210507-25	8.5
	16 ~ 22	PT29415-25	8.0
	23 ~ 33	PT28407-25 PT28407-15	6.2
	34 ~ 49	PT27315-25 PT27315-15	6.2
	50 ~ 80	PT26307-25 PT26307-15	6.2
	81 ~ 94	PT26307-15 PT26307-09	6.2/7.0
	95 ~ 125	PT25215-15* PT25215-09*	5.4/7.0
	126 ~ 174	PT25215-09*	7.0
	175 ~ 200	PT24207-09*	6.5
	30	13 ~ 19	PT210507-25
20 ~ 27		PT29415-25 PT29415-15	8.0
28 ~ 41		PT28407-25 PT28407-15	6.2
42 ~ 60		PT27315-25 PT27315-15	6.2
61 ~ 76		PT26307-25 PT26307-15	6.2
77 ~ 89		PT26307-15 PT26307-09	6.2/7.0
90 ~ 125		PT26307-15* PT26307-09*	6.2/7.0
126 ~ 200		PT25215-09*	7.0
40	18 ~ 25	PT210507-25	8.5
	26 ~ 36	PT29415-25 PT29415-15	8.0
	37 ~ 56	PT28407-25 PT28407-15	6.2
	57 ~ 75	PT27315-25 PT27315-15	6.2
	76 ~ 88	PT27315-15	6.2
	89 ~ 114	PT26307-15*	6.2
	115 ~ 120	PT26307-15* PT26307-09*	6.2/7.0
	121 ~ 200	PT26307-09*	7.0
	22 ~ 32	PT210507-25	8.5
	33 ~ 46	PT29415-25 PT29415-15	8.0
50	47 ~ 70	PT28407-25 PT28407-15	6.2
	71 ~ 72	PT28407-25 PT28407-15	6.2
	73 ~ 95	PT27315-15*	6.2
	96 ~ 110	PT27315-15* PT27315-09	6.2/7.0
	111 ~ 120	PT27315-15* PT27315-09*	6.2/7.0
	121 ~ 179	PT27315-09*	7.0
	180 ~ 200	PT26307-09*	7.0
	60	27 ~ 39	PT210507-25
40 ~ 56		PT29415-25 PT29415-15	8.0
57 ~ 70		PT28407-25 PT28407-15	6.2
71 ~ 75		PT28407-25 PT28407-15	6.2
76 ~ 89		PT28407-15	6.2
90 ~ 120		PT27315-15* PT27315-09*	6.2/7.0
75	121 ~ 200	PT27315-09*	7.0
	34 ~ 49	PT210507-25	8.5
	50 ~ 73	PT29415-25 PT29415-15	8.0
	74 ~ 75	PT28407-25 PT28407-15	6.2
	76 ~ 120	PT28407-15*	6.2
	121 ~ 133	PT27315-09*	7.0
	134 ~ 200	PT27315-09*	7.0
100	46 ~ 67	PT210507-25	8.5
	68 ~ 75	PT29415-25* PT29415-15*	8.0
	76 ~ 103	PT29415-15*	8.0
	104 ~ 120	PT28407-15*	6.2
	181 ~ 200	PT27315-09*	7.0
125	59 ~ 79	PT210507-25*	8.5
	80 ~ 120	PT29415-15*	8.0
150	73 ~ 75	PT210507-25*	8.5

*Additional Cooling Provisions May Be Required. consult Factory with Application Details.

DOWNLOAD AVAILABLE CAD MODELS AT: WWW.HUBCITYINC.COM

Certified prints are available upon request

EMAIL: hubsales@regalbeloit.com • www.hubcityinc.com



Hub City PowerTorque® Shaft Mount Reducers

Selection By Input Horsepower

Class III Service

HP	OUTPUT RPM	REDUCER SELECTION	MINIMUM SHEAVE DIA.
0.25	4 ~ 6	PT22115-25	3.0
	7 ~ 70	PT21107-25 PT21107-15	3.0
	71 ~ 85	PT21107-25 PT21107-15	3.0
	86 ~ 89	PT21107-15 PT21107-09	3.0/4.0
	90 ~ 115	PT21107-15 PT21107-09	3.0/4.0
	116 ~ 140	PT21107-15 PT21107-09	3.0/4.0
	141 ~ 200	PT21107-09	4.0
0.33	5 ~ 9	PT22115-25	3.0
	10 ~ 70	PT21107-25 PT21107-15	3.0
	71 ~ 85	PT21107-25 PT21107-15	3.0
	86 ~ 115	PT21107-15 PT21107-09	3.0/4.0
	116 ~ 140	PT21107-15 PT21107-09	3.0/4.0
0.50	141 ~ 200	PT21107-09	4.0
	4 ~ 5	PT24207-25	4.6
	6 ~ 7	PT23203-25	4.0
	8 ~ 15	PT22115-25	3.0
	16 ~ 70	PT21107-25 PT21107-15	3.0
	71 ~ 85	PT21107-25 PT21107-15	3.0
	86 ~ 115	PT21107-15 PT21107-09	3.0/4.0
	116 ~ 140	PT21107-15 PT21107-09	3.0/4.0
0.75	141 ~ 200	PT21107-09	4.0
	4	PT25215-25	5.4
	5 ~ 7	PT24207-25	4.6
	8 ~ 12	PT23203-25	4.0
	13 ~ 23	PT22115-25	3.0
	24 ~ 70	PT21107-25 PT21107-15	3.0
	71 ~ 85	PT21107-25 PT21107-15	3.0
	86 ~ 115	PT21107-15 PT21107-09	3.0/4.0
	116 ~ 140	PT21107-15 PT21107-09	3.0/4.0
1.00	141 ~ 200	PT21107-09	4.0
	4 ~ 6	PT25215-25	5.4
	7 ~ 10	PT24207-25	4.6
	11 ~ 17	PT23203-25	4.0
	18 ~ 32	PT22115-25	3.0
	33 ~ 70	PT21107-25 PT21107-15	3.0
	71 ~ 85	PT21107-25 PT21107-15	3.0
	86 ~ 115	PT21107-15 PT21107-09	3.0/4.0
	116 ~ 140	PT21107-15 PT21107-09	3.0/4.0
1.5	141 ~ 200	PT21107-09	4.0
	4 ~ 5	PT26307-25	6.2
	6 ~ 10	PT25215-25	5.4
	11 ~ 15	PT24207-25	4.6
	16 ~ 26	PT23203-25	4.0
	27 ~ 51	PT22115-25 PT22115-15	3.0
	52 ~ 70	PT21107-25 PT21107-15	3.0
	71 ~ 85	PT21107-25 PT21107-15	3.0
	86 ~ 115	PT21107-15 PT21107-09	3.0/4.0
	116 ~ 140	PT21107-15 PT21107-09	3.0/4.0
	141 ~ 200	PT21107-09	4.0

HP	OUTPUT RPM	REDUCER SELECTION	MINIMUM SHEAVE DIA.	
2	5 ~ 7	PT26307-25	6.2	
	8 ~ 13	PT25215-25	5.4	
	14 ~ 21	PT24207-25	4.6	
	22 ~ 36	PT23203-25 PT23203-15	4.0	
	37 ~ 71	PT22115-25 PT22115-15	3.0	
	72 ~ 85	PT21107-25 PT21107-15	3.0	
	86 ~ 115	PT21107-15 PT21107-09	3.0/4.0	
	116 ~ 140	PT21107-15 PT21107-09	3.0/4.0	
	141 ~ 200	PT21107-09	4.0	
	3	4 ~ 5	PT28407-25	6.2
6 ~ 7		PT27315-25	6.2	
8 ~ 12		PT26307-25	6.2	
13 ~ 20		PT25215-25	5.4	
21 ~ 32		PT24207-25 PT24207-15	4.6	
33 ~ 57		PT23203-25 PT23203-15	4.0	
58 ~ 70		PT22115-25 PT22115-15	3.0	
71 ~ 85		PT22115-25 PT22115-15	3.0	
86 ~ 89		PT22115-15 PT22115-09	3.0/5.0	
90 ~ 113		PT22115-15 PT22115-09	3.0/5.0	
114 ~ 140		PT21107-15 PT21107-09	3.0/4.0	
141 ~ 200		PT21107-09	4.0	
5		5	PT29415-25	8.0
		6 ~ 8	PT28407-25	6.2
	9 ~ 12	PT27315-25	6.2	
	13 ~ 20	PT26307-25	6.2	
	21 ~ 36	PT25215-25 PT25215-15	5.4	
	37 ~ 56	PT24207-25 PT24207-15	4.6	
	57 ~ 70	PT23203-25 PT23203-15	4.0	
	71 ~ 85	PT23203-25 PT23203-15	4.0	
	86 ~ 103	PT23203-15 PT23203-09	4.0/5.0	
	104 ~ 114	PT22115-15 PT23203-09	3.0/5.0	
	115 ~ 140	PT22115-15 PT22115-09	3.0/5.0	
	141 ~ 167	PT22115-09	5.0	
	168 ~ 200	PT22115-09	5.0	
	7.5	5 ~ 6	PT210507-25	8.5
		7 ~ 8	PT29415-25	8.0
		9 ~ 13	PT28407-25	6.2
14 ~ 19		PT27315-25	6.2	
20 ~ 32		PT26307-25 PT26307-15	6.2	
33 ~ 56		PT25215-25 PT25215-15	5.4	
57 ~ 70		PT24207-25 PT24207-15	4.6	
71 ~ 85		PT24207-25 PT24207-15	4.6	
86 ~ 93		PT24207-15 PT24207-09	4.6/6.5	
94 ~ 140		PT23203-15 PT23203-09	4.0/5.0	
141 ~ 144		PT23203-09	5.0	
145 ~ 200		PT23203-09	5.0	

*Additional Cooling Provisions May Be Required. consult Factory with Application Details.

DOWNLOAD AVAILABLE CAD MODELS AT: WWW.HUBCITYINC.COM

Certified prints are available upon request

CALL: (605) 225-0360 • FAX: (605) 225-0567

Hub City PowerTorque® Shaft Mount Reducers

Selection By Input Horsepower

Class III Service cont.

HP	OUTPUT RPM	REDUCER SELECTION	MINIMUM SHEAVE DIA.
10	7 ~ 8	PT210507-25	8.5
	9 ~ 12	PT29415-25	8.0
	13 ~ 18	PT28407-25	6.2
	19 ~ 26	PT27315-25 PT27315-15	6.2
	27 ~ 45	PT26307-25 PT26307-15	6.2
	46 ~ 70	PT25215-25 PT25215-15	5.4
	71 ~ 78	PT25215-25 PT25215-15	5.4
	79 ~ 92	PT24207-15 PT24207-09	4.6
	93 ~ 105	PT24207-15 PT24207-09	4.6/6.5
	106 ~ 141	PT24207-15 PT24207-09	4.6/6.5
	142 ~ 200	PT23203-09	5.0
15	10 ~ 13	PT210507-25	8.5
	14 ~ 19	PT29415-25	8.0
	20 ~ 28	PT28407-25 PT28407-15	6.2
	29 ~ 41	PT27315-25 PT27315-15	6.2
	42 ~ 70	PT26307-25 PT26307-15	6.2
	71 ~ 75	PT26307-25 PT26307-15	6.2
	76 ~ 93	PT25215-15	5.4
	94 ~ 115	PT25215-15 PT25215-09	5.4/7.0
	116 ~ 125	PT25215-15 PT25215-09	5.4/7.0
	126 ~ 131	PT25215-09	7.0
	132 ~ 200	PT24207-09	6.5
20	13 ~ 18	PT210507-25	8.5
	19 ~ 25	PT29415-25 PT29415-15	8.0
	26 ~ 38	PT28407-25 PT28407-15	6.2
	39 ~ 57	PT27315-25 PT27315-15	6.2
	58 ~ 70	PT26307-25 PT26307-15	6.2
	71 ~ 114	PT26307-15 PT26307-09	6.2/7.0
	115 ~ 125	PT25215-15* PT25215-09*	5.4/7.0
	126 ~ 200	PT25215-09*	7.0
25	16 ~ 22	PT210507-25	8.5
	23 ~ 32	PT29415-25 PT29415-15	8.0
	33 ~ 49	PT28407-25 PT28407-15	6.2
	50 ~ 70	PT27315-25 PT27315-15	6.2
	71 ~ 74	PT27315-25 PT27315-15	6.2
	75 ~ 104	PT26307-15	6.2
	105 ~ 113	PT26307-15* PT26307-09	6.2/7.0
	114 ~ 125	PT26307-15* PT26307-09*	6.2/7.0
126 ~ 200	PT26307-09*	7.0	
30	19 ~ 27	PT210507-25	8.5
	28 ~ 39	PT29415-25 PT29415-15	8.0
	40 ~ 60	PT28407-25 PT28407-15	6.2
	61 ~ 70	PT27315-25 PT27315-15	6.2
	71 ~ 98	PT27315-15	6.2
	99 ~ 125	PT26307-15	6.2
	126 ~ 131	PT26307-09*	7.0
132 ~ 200	PT26307-09*	7.0	

HP	OUTPUT RPM	REDUCER SELECTION	MINIMUM SHEAVE DIA.
40	26 ~ 37	PT210507-25	8.5
	38 ~ 53	PT29415-25 PT29415-15	8.0
	54 ~ 70	PT28407-25 PT28407-15	6.2
	71 ~ 84	PT28407-15	6.2
	85 ~ 89	PT27315-15 PT27315-09	6.2/7.0
	90 ~ 120	PT27315-15* PT27315-09	6.2/7.0
	121 ~ 200	PT27315-09*	7.0
50	32 ~ 46	PT210507-25	8.5
	47 ~ 69	PT29415-25 PT29415-15	8.0
	70 ~ 75	PT28407-25 PT28407-15	6.2
	76 ~ 110	PT28407-15	6.2
	111 ~ 120	PT27315-15* PT27315-09*	6.2/7.0
60	121 ~ 123	PT27315-09*	7.0
	124 ~ 200	PT27315-09*	7.0
	39 ~ 56	PT210507-25	8.5
	57 ~ 75	PT29415-25 PT29415-15	8.0
75	76 ~ 85	PT29415-15	8.0
	86 ~ 115	PT28407-15	6.2
	142 ~ 161	PT27315-09*	7.0
	162 ~ 200	PT27315-09*	7.0
	50 ~ 72	PT210507-25	8.5
73 ~ 75	PT29415-25* PT29415-15*	8.0	
76 ~ 120	PT29415-15*	8.0	

*Additional Cooling Provisions May Be Required. consult Factory with Application Details.

DOWNLOAD AVAILABLE CAD MODELS AT: WWW.HUBCITYINC.COM

Certified prints are available upon request

EMAIL: hubsales@regalbeloit.com • www.hubcityinc.com



Hub City PowerTorque® Shaft Mount Reducers

Mechanical Ratings

Input Horsepower And Output Torque, 1.00 Service Factor

9/1 Nominal Ratio

OUTPUT	PT21107		PT22115		PT23203		PT24207	
	ACTUAL RATIO 8.92:1		ACTUAL RATIO 9.25:1		ACTUAL RATIO 8.91:1		ACTUAL RATIO 9.68:1	
	INPUT RPM	OUTPUT TORQUE HP	INPUT (IN-LB)	OUTPUT TORQUE HP	INPUT (IN-LB)	OUTPUT TORQUE HP	INPUT (IN-LB)	OUTPUT TORQUE HP(IN-LB)
200	9.1	2753	11.6	3494	30.1	9118	45.0	13598
190	8.8	2802	11.0	3503	28.7	9133	42.7	13604
180	8.5	2857	10.4	3503	27.2	9150	40.6	13630
170	8.3	2954	9.9	3506	25.8	9165	38.3	13635
160	8.0	3025	9.3	3513	24.3	9178	36.1	13663
150	7.6	3066	8.7	3517	22.8	9193	33.9	13666
140	7.2	3112	8.1	3518	21.3	9205	31.7	13700
120	6.4	3227	7.0	3529	18.3	9247	27.3	13739
100	5.6	3388	5.9	3539	15.3	9281	22.8	13783

15/1 Nominal Ratio

OUTPUT RPM	PT21107		PT22115		PT23203		PT24207		PT25215	
	ACTUAL RATIO 15.35:1		ACTUAL RATIO 14.10:1		ACTUAL RATIO 14.88:1		ACTUAL RATIO 15.13:1		ACTUAL RATIO 15.40:1	
	INPUT HP	OUTPUT TORQUE (IN-LB)	INPUT HP	OUTPUT TORQUE (IN-LB)	INPUT HP	OUTPUT TORQUE (IN-LB)	INPUT HP	OUTPUT TORQUE (IN-LB)	INPUT HP	OUTPUT TORQUE (IN-LB)
140	7.5	3220	11.6	5013	19.7	8496	31.8	13743		
130	7.0	3235	11.0	5124	18.7	8689	30.2	14051	44.0	20464
120	6.5	3252	10.4	5249	17.7	8899	28.6	14395	41.6	20955
100	5.4	3291	9.2	5548	15.5	9402	25.1	15205	36.6	22132
80	4.4	3343	7.8	5929	13.3	10051	20.5	15497	31.3	23657
60	3.4	3398	6.4	6464	10.5	10558	15.7	15822	25.6	25805
40	2.3	3479	4.8	7306	7.2	10891	10.7	16215	18.2	27529
30	1.7	3509	3.9	7765	5.4	10951	8.2	16457	13.9	27973
20	1.2	3570	2.6	7896	3.7	11133	5.5	16760	9.6	28891

25/1 Nominal Ratio

OUTPUT RPM	PT21107		PT22115		PT23203		PT24207		PT25215	
	ACTUAL RATIO 23.93:1		ACTUAL RATIO 23.46:1		ACTUAL RATIO 24.71:1		ACTUAL RATIO 24.38:1		ACTUAL RATIO 25.56:1	
	INPUT HP	OUTPUT TORQUE (IN-LB)	INPUT HP	OUTPUT TORQUE (IN-LB)	INPUT HP	OUTPUT TORQUE (IN-LB)	INPUT HP	OUTPUT TORQUE (IN-LB)	INPUT HP	OUTPUT TORQUE (IN-LB)
85	4.7	3310	8.1	5787	14.2	10093	21.5	15332	32.6	23234
75	4.2	3348	7.5	6067	12.7	10245	19.3	15570	29.9	24121
65	3.7	3398	6.8	6339	11.2	10416	17.0	15824	27.1	25179
55	3.1	3454	6.1	6655	9.6	10594	14.7	16116	24.1	26468
45	2.6	3496	5.2	7018	8.0	10810	12.2	16457	20.2	27133
35	2.1	3578	4.2	7174	6.4	11029	9.7	16837	16.1	27797
25	1.5	3654	3.0	7357	4.6	11205	7.2	17328	11.8	28630
15	0.94	3792	1.9	7543	2.8	11415	4.4	17788	7.3	29244
5	0.32	3872	0.65	7866	1.0	11617	1.5	18030	2.5	30131

DOWNLOAD AVAILABLE CAD MODELS AT: WWW.HUBCITYINC.COM

Certified prints are available upon request

CALL: (605) 225-0360 • FAX: (605) 225-0567

Hub City PowerTorque® Shaft Mount Reducers

Mechanical Ratings

Input Horsepower And Output Torque, 1.00 Service Factor

9/1 Nominal Ratio

OUTPUT RPM	PT25215		PT26307		PT27315	
	ACTUAL RATIO 8.96:1		ACTUAL RATIO 9.21:1		ACTUAL RATIO 9.62:1	
	INPUT HP	OUTPUT TORQUE (IN-LB)	INPUT HP	OUTPUT TORQUE (IN-LB)	INPUT HP	OUTPUT TORQUE (IN-LB)
200	68.0	20577	95.3	28839	151	45535
190	64.7	20594	90.7	28895	145	46066
180	61.4	20642	86.0	28914	139	46605
170	58.1	20664	81.4	28978	132	47150
160	54.7	20681	76.7	28997	126	47700
150	51.3	20700	72.1	29066	119	48173
140	48.0	20762	67.3	29085	114	49423
120	41.3	20803	57.9	29183	99.8	50339
100	34.6	20904	48.4	29290	84.8	51313

15/1 Nominal Ratio

OUTPUT RPM	PT26307		PT27315		PT28407		PT29415	
	ACTUAL RATIO 15.33:1		ACTUAL RATIO 15.23:1		ACTUAL RATIO 15.08:1		ACTUAL RATIO 15.12:1	
	INPUT HP	OUTPUT TORQUE (IN-LB)	INPUT HP	OUTPUT TORQUE (IN-LB)	INPUT HP	OUTPUT TORQUE (IN-LB)	INPUT HP	OUTPUT TORQUE (IN-LB)
140								
130	82.9	38583						
120	77.1	38894	100	50596	163	82270	236	118795
100	65.4	39576	88.4	53473	139	83883	200	121208
80	53.4	40364	75.7	57222	113	85711	164	124018
60	41.0	41294	60.3	60756	87.2	87973	126.3	127391
40	28.1	42444	41.4	62561	60.0	90741	87.0	131626
30	21.4	43180	31.6	63711	45.9	92490	66.6	134258
20	15.0	45227	21.5	65072	31.3	94628	45.5	137526

25/1 Nominal Ratio

OUTPUT RPM	PT26307		PT27315		PT28407		PT29415		PT210507	
	ACTUAL RATIO 25.13:1		ACTUAL RATIO 24.59:1		ACTUAL RATIO 24.62:1		ACTUAL RATIO 25.97:1		ACTUAL RATIO 24.30:1	
	INPUT HP	OUTPUT TORQUE (IN-LB)	INPUT HP	OUTPUT TORQUE (IN-LB)	INPUT HP	OUTPUT TORQUE (IN-LB)	INPUT HP	OUTPUT TORQUE (IN-LB)	INPUT HP	OUTPUT TORQUE (IN-LB)
85	56.0	39890								
75	50.3	40578	72.1	58197	105	84706	155	124800	216	174252
65	44.4	41338	63.7	59331	94.4	87908	135.8	126425	193.2	179827
55	38.4	42188	55.1	60614	81.8	90008	116.6	128290	166.0	182590
45	32.1	43160	45.2	60706	68.2	91697	97.0	130460	138.2	185801
35	25.6	44306	36.4	62838	53.4	92260	76.9	132867	109.5	189343
25	18.9	45620	26.2	63408	38.5	93128	56.1	135795	80.1	193831
15	11.8	47395	16.0	64699	23.6	94991	34.6	139563	49.5	199542
5	4.0	48282	5.4	65223	8.5	102252	12.0	145452	17.2	208497

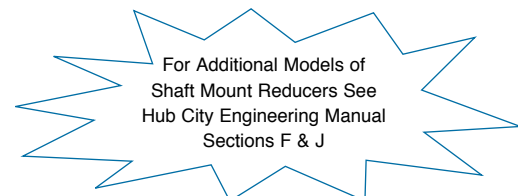

DOWNLOAD AVAILABLE CAD MODELS AT: WWW.HUBCITYINC.COM

Certified prints are available upon request

EMAIL: hubsales@regalbeloit.com • www.hubcityinc.com



Hub City PowerTorque® Shaft Mount Reducers

Dimensions

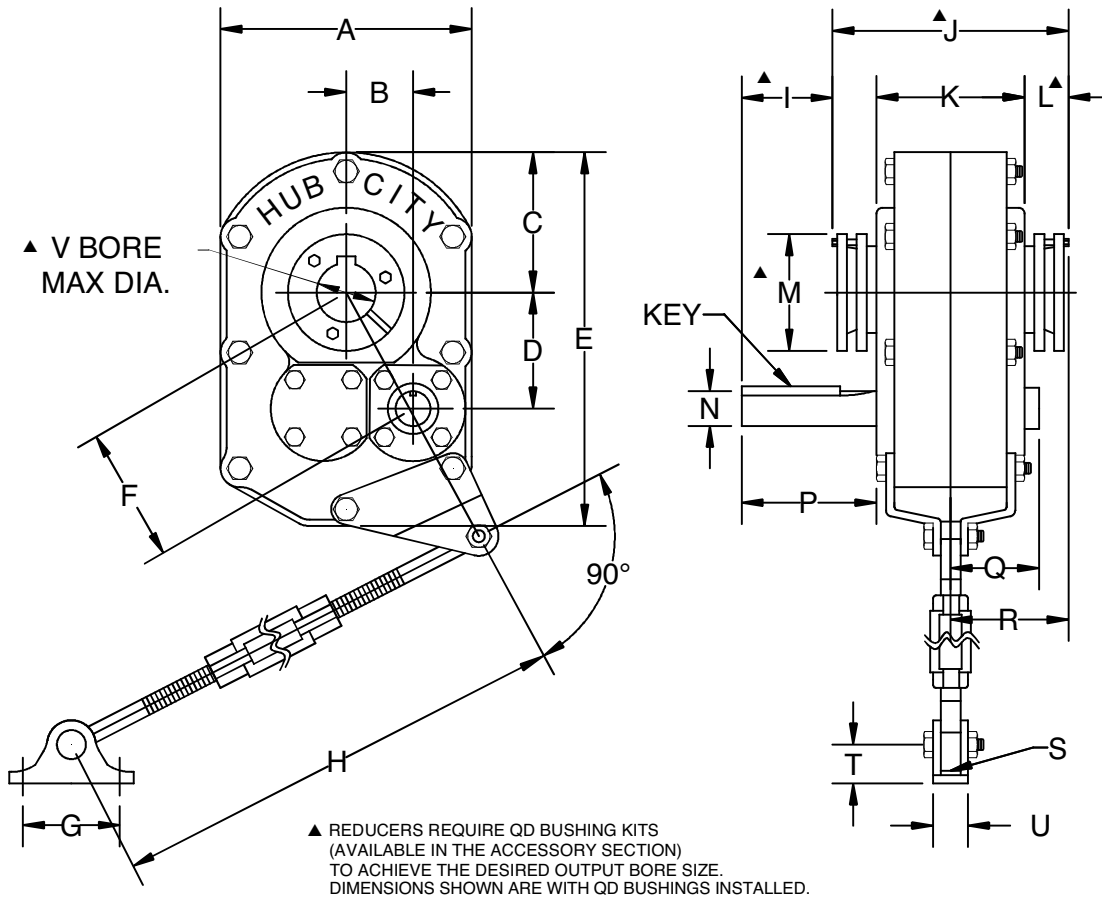

MODEL	A	B	C	D	E	F	G	H MIN/MAX	I	J	K
PT21107	7.13	1.91	3.75	3.18	9.94	3.71	2.50	23.81/29.63	2.03	7.06	4.06
PT22115	8.38	2.14	4.09	3.75	11.41	4.32	3.00	26.94/32.94	2.22	7.32	4.50
PT23203	9.25	2.33	4.84	4.17	12.88	4.78	3.00	26.94/32.94	2.34	9.22	5.63
PT24207	10.38	2.76	5.50	4.79	15.13	5.53	4.00	29.19/35.14	3.44	9.98	6.13
PT25215	13.13	3.04	6.56	5.67	18.31	6.43	4.00	29.19/35.19	3.44	10.52	6.31
PT26307	15.43	4.09	7.56	6.73	21.31	7.88	4.75	29.19/35.19	3.73	11.53	6.88
PT27315	18.75	5.11	9.38	8.30	25.94	9.74	4.75	29.44/35.44	3.75	12.85	7.75
PT28407	20.25	6.03	10.13	9.50	28.25	11.25	7.00	30.00/36.00	4.31	14.03	8.37
PT29415	22.63	6.59	11.31	10.81	31.69	12.66	7.00	30.00/36.00	3.63	14.12	8.12
PT210507	25.50	6.59	12.75	12.50	35.08	14.13	7.00	30.00/36.00	6.53	15.30	9.34

MODEL	L	M	Q	R	S	T	U	V MAX DIA	INPUT SHAFT			APPROX. WEIGHT (LB)
									N DIA	P	KEY	
PT21107	1.30	3.25	2.67	3.55	.38	.94	1.06	1-7/16	0.750	2.70	3/16x3/16x1-29/32	45
PT22115	1.40	4.06	2.89	3.68	0.44	1.06	1.25	1 15/16	1.125	3.75	1/4x1/4x1-15/16	58
PT23203	1.59	4.38	3.30	3.72	0.44	1.06	1.25	2 3/16	1.250	3.89	1/4x1/4x2-13/16	98
PT24207	1.72	4.81	3.41	3.91	0.50	1.75	1.44	2 7/16	1.438	5.21	3/8x3/8x4	139
PT25215	1.91	5.63	4.45	5.05	0.50	1.75	1.44	2 15/16	1.938	5.36	1/2x1/2x4	207
PT26307	2.30	6.13	4.57	5.73	0.63	2.00	2.75	3 7/16	2.188	5.69	1/2x1/2x4-13/32	285
PT27315	2.50	7.25	4.69	6.38	0.63	2.00	2.75	3 15/16	2.438	5.90	5/8x5/8x4-1/2	462
PT28407	2.86	7.75	5.85	7.04	0.75	3.13	4.00	4 7/16	2.438	6.64	5/8x5/8x5-5/16	633
PT29415	2.98	8.75	5.66	7.04	0.75	3.13	4.00	4 5/16	2.438	9.26	5/8x5/8x6-1/2	760
PT210507	2.99	10.13	6.96	7.66	0.75	3.13	4.00	5 7/16	2.688	9.09	5/8x5/8x7-11/16	1020

For Lubrication and Installation Instructions Refer to Section S.

DOWNLOAD AVAILABLE CAD MODELS AT: WWW.HUBCITYINC.COM

Certified prints are available upon request

CALL: (605) 225-0360 • FAX: (605) 225-0567

Hub City PowerTorque® Shaft Mount Reducers

Accessories

Tapered Bushing Kits

- Flanged bushing mount
- Removal screws allow for easy demounting
- Ductile iron material for shock resistance
- Clamp fit, no setscrews
- Split design eliminates seizing problems
- Kits include two bushings, key and mounting hardware



SHAFT MOUNT MODEL	BORE SIZE	PART NUMBER	WEIGHT (LBS.)	SHAFT MOUNT MODEL	BORE SIZE	PART NUMBER	WEIGHT (LBS.)
PT21107	1-7/16	0279-00001	2.8	PT26307	3-7/16	0279-00076	9
	1-3/8	0279-00002	2.9		3	0279-00077	11.4
	1-5/16	0279-00003	2.9		2-15/16	0279-00078	11.7
	1-1/4	0279-00004	3.0		2-7/16	0279-00082	12.4
PT22115	1-15/16	0279-00016	3	PT27315	3-15/16	0279-00091	12.9
	1-3/4	0279-00017	3.4		3-7/16	0279-00092	13.9
	1-11/16	0279-00018	3.5		3-3/16	0279-00093	16.8
	1-5/8	0279-00019	3.6		3	0279-00094	19.2
PT23203	2-3/16	0279-00031	3.7	PT28407	4-7/16	0279-00106	15.1
	2	0279-00032	4.3		4-3/16	0279-00107	17.4
	1-15/16	0279-00033	4.6		3-15/16	0279-00108	20.2
	1-7/8	0279-00034	4.8		3-7/16	0279-00109	25.6
PT24207	2-7/16	0279-00046	5.9	PT29415	4-15/16	0279-00120	25
	2-1/4	0279-00047	6.4		4-7/16	0279-00121	27
	2-3/16	0279-00048	6.8		3-15/16	0279-00122	28
	2-1/8	0279-00049	7.1		3-7/16	0279-00123	30
PT25215	2-15/16	0279-00061	7.8	PT210507	5-7/16	0279-00136	28
	2-11/16	0279-00062	7.9		4-15/16	0279-00137	33
	2-1/2	0279-00063	8.5		4-7/16	0279-00138	36
	2-7/16	0279-00064	8.6		3-15/16	0279-00139	40

Backstop Kits

- Quick installation on input shaft
- Internally installed, sealed from contamination
- Lubricated by internal gear lubricant
- Designed to operate in either direction



SHAFT MOUNT MODEL	PART NUMBER	WEIGHT (LBS.)
PT21107 & PT22115	0279-00166	1
PT22115*	0279-00167	1
PT23203	0279-00166	1
PT24207	0279-00169	1.2
PT25215	0279-00170	2.2
PT26307	0279-00171	2.5
PT27315	0279-00172	2.8
PT28407 & PT29415	0279-00173	3.8
PT210507	0279-00175	6

* Use for PT2115 without end caps (ball bearing)

DOWNLOAD AVAILABLE CAD MODELS AT: WWW.HUBCITYINC.COM

Certified prints are available upon request

EMAIL: hubsales@regalbeloit.com • www.hubcityinc.com



Hub City PowerTorque® Shaft Mount Reducers Accessories

Vertical Motor Mounts



All-Steel construction for rigidity
Compact design eliminates need for motor base
Top plate adjusts for easy tensioning of drive belt
Mounting holes provided match NEMA standards

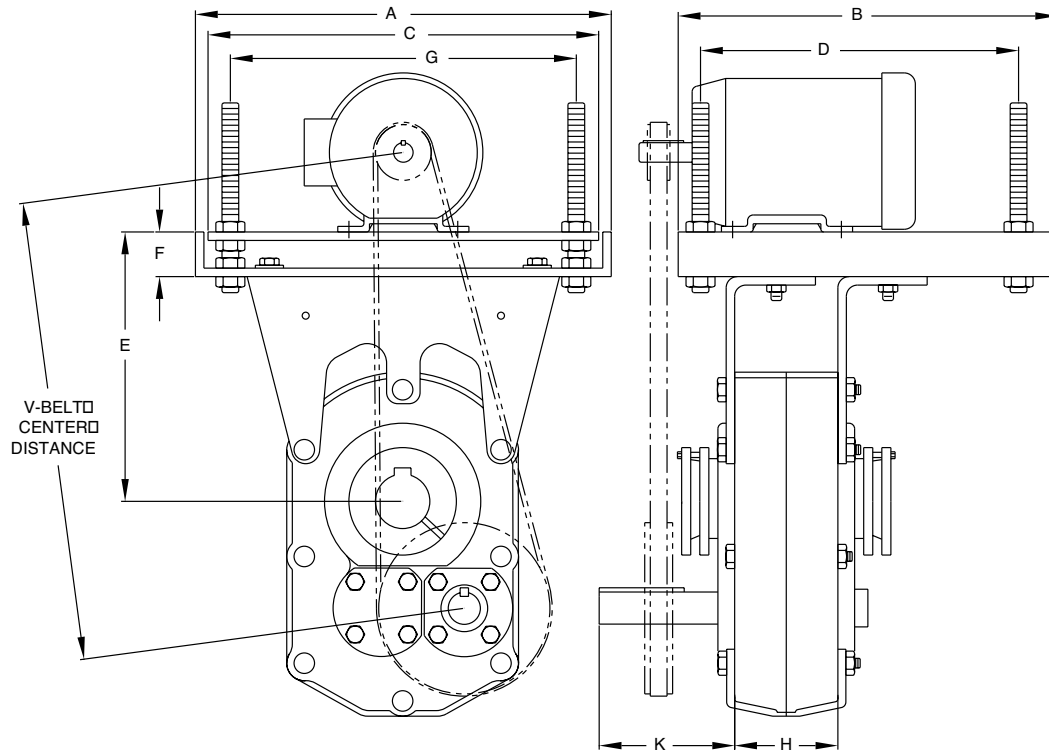

NOTE: SHIELDS/GUARDS NOT SHOWN FOR ILLUSTRATION PURPOSES

DOWNLOAD AVAILABLE CAD MODELS AT: WWW.HUBCITYINC.COM

Certified prints are available upon request

CALL: (605) 225-0360 • FAX: (605) 225-0567

Hub City PowerTorque® Shaft Mount Reducers Accessories

Vertical Motor Mounts

VERTICAL MOTOR MOUNTS																
SHAFT MOUNT	PART NUMBER	NEMA MOTOR	V-BELT CENTER DISTANCE FOR NEMA MOTOR FRAMES													
			56-140 MIN	56-140 MAX	180 MIN	180 MAX	210 MIN	210 MAX	250 MIN	250 MAX	280 MIN	280 MAX	320 MIN	320 MAX	360 MIN	360 MAX
PT21107	0279-00180	56C-215T	17.6	21.0	18.5	22.0	19.3	22.7								
PT22115	0279-00181	56C-215T	18.7	22.1	19.7	23.1	20.5	23.9								
PT23203	0279-00182	56C-215T	20.2	23.6	21.2	24.6	22.0	25.3								
PT23203	0279-00183	143T-286T	20.4	23.8	21.4	24.8	22.2	25.5	23.2	26.5	23.9	27.2				
PT24207	0279-00184	143T-286T	21.2	25.2	22.2	26.2	23.0	26.9	23.9	27.9	24.7	28.7				
PT24207	0279-00189	143T-326T	21.3	25.3	22.3	26.3	23.1	27.0	24.0	28.0	24.8	28.8	25.8	29.8		
PT25215	0279-00185	143T-286T	22.7	26.6	23.7	27.6	24.4	28.4	25.4	29.4	26.2	30.1				
PT25215	0279-00186	143T-326T	22.8	26.7	23.8	27.7	24.5	28.5	25.5	29.5	26.3	30.2	27.3	31.2		
PT26307	0279-00187	143T-326T	25.9	29.7	26.9	30.7	31.4	37.6	28.6	32.4	29.4	33.2	30.4	34.2		
PT27315	0279-00188	143T-365T	30.6	34.4	31.6	35.4	32.4	36.2	33.4	37.2	34.1	37.9	35.1	38.9	36.1	39.9
PT28407	0279-00190	143T-365T	31.9	36.4	32.9	37.4	33.7	38.2	34.7	39.2	35.4	39.9	36.4	40.9	37.4	41.9
PT29415	0279-00191	143T-365T	32.0	35.8	33.0	36.8	33.8	37.6	34.8	38.6	32.8	39.3	36.5	40.3	37.5	41.4
PT210507	0279-00193	143T-365T	33.5	37.3	34.5	38.3	35.3	39.1	36.3	40.1	34.3	40.8	38.0	41.8	39.0	42.9

SHAFT MOUNT	PART NUMBER	WEIGHT (LBS.)	A	B	C	D	E		F	G	H	J	K
							MIN	MAX					
PT21107	0279-00180	35	14.63	11.00	13.50	9.25	10.0	14.2	1.59	12.00	3.38	5/8x7	3.88
PT22115	0279-00181	35	14.63	11.00	13.50	9.25	10.6	14.8	1.59	12.00	3.38	5/8x7	4.18
PT23203	0279-00182	35	14.63	11.00	13.50	9.25	11.6	15.9	1.59	12.00	4.25	5/8x8	4.88
PT23203	0279-00183	77	18.63	17.00	17.50	14.25	11.8	16.0	1.78	15.50	4.25	3/4x8	4.88
PT24207	0279-00184	87	18.63	17.00	17.50	14.25	12.0	16.7	1.78	15.50	4.63	3/4x8	6.13
PT24207	0279-00189	121	20.50	18.50	19.25	16.50	12.0	16.8	1.84	17.50	4.63	3/4x8	6.13
PT25215	0279-00185	84	18.63	17.00	17.50	14.25	12.5	17.3	1.78	15.50	4.13	3/4x8	6.65
PT25215	0279-00186	118	20.50	18.50	19.25	16.50	12.5	17.3	1.84	17.50	4.13	3/4x8	6.65
PT26307	0279-00187	118	20.50	18.50	19.25	16.50	14.6	19.3	1.84	17.50	4.50	3/4x8	7.31
PT27315	0279-00188	148	22.50	19.00	21.25	16.50	17.6	22.1	2.50	19.25	4.75	1x9	7.81
PT28407	0279-00190	148	22.50	19.00	21.25	16.50	18.3	22.8	2.50	19.25	4.75	1x9	8.81
PT29415	0279-00191	125	22.50	19.00	21.25	16.50	19.0	23.5	2.50	19.25	5.40	1x9	11.08
PT210507	0279-00193	135	22.50	19.00	21.25	16.50	20.5	25.0	2.50	19.25	6.18	1x9	11.15

Vertical Long Motor Mounts

VERTICAL LONG MOTOR MOUNTS																
SHAFT MOUNT	PART NUMBER	NEMA MOTOR	V-BELT CENTER DISTANCE FOR NEMA MOTOR FRAMES													
			56-140 MIN	56-140 MAX	180 MIN	180 MAX	210 MIN	210 MAX	250 MIN	250 MAX	280 MIN	280 MAX	320 MIN	320 MAX	360 MIN	360 MAX
PT21107	0279-00196	56C-215T	20.6	24.0	21.5	25.0	22.3	25.7								
PT22115	0279-00197	56C-215T	21.7	25.1	22.7	26.1	23.5	26.9								
PT23203	0279-00198	56C-215T	23.2	26.6	24.2	27.6	25.0	28.3								
PT23203	0279-00199	143T-286T	23.4	26.8	24.4	27.8	25.2	28.5	26.2	29.5	26.9	30.2				
PT24207	0279-00200	143T-286T	25.7	29.7	26.7	30.7	27.5	31.4	28.4	32.4	29.2	33.2				
PT24207	0279-00201	143T-326T	25.8	29.8	26.8	30.8	27.6	31.5	28.5	32.5	29.3	33.3	30.3	34.3		
PT25215	0279-00202	143T-286T	29.5	33.4	30.5	34.4	31.2	35.2	32.2	36.2	33.0	36.9				
PT25215	0279-00203	143T-326T	29.5	33.4	30.5	34.4	31.2	35.2	32.2	36.2	33.0	36.9	34.0	37.9		
PT26307	0279-00204	143T-326T	39.9	43.7	40.9	44.7	45.4	51.6	42.6	46.4	43.4	47.2	44.4	48.2		
PT27315	0279-00205	143T-365T	45.6	49.4	46.6	50.4	47.4	51.2	48.4	52.2	49.1	52.9	50.1	53.9	51.1	54.9
PT28407	0279-00206	143T-365T	44.9	49.4	45.9	50.4	46.7	51.2	47.7	52.2	48.4	52.9	49.4	53.9	50.4	54.9

SHAFT MOUNT	PART NUMBER	WEIGHT (LBS.)	A	B	C	D	E		F	G	H	J	K
							MIN	MAX					
PT21107	0279-00196	41	14.63	11.00	13.50	9.25	13.0	17.2	1.59	12.00	3.38	5/8x7	3.88
PT22115	0279-00197	41	14.63	11.00	13.50	9.25	13.6	17.8	1.59	12.00	3.38	5/8x7	4.18
PT23203	0279-00198	41	14.63	11.00	13.50	9.25	14.6	18.8	1.59	12.00	4.25	5/8x8	4.88
PT23203	0279-00199	83	18.63	17.00	17.50	14.25	14.8	19.0	1.78	15.50	4.25	3/4x8	4.88
PT24207	0279-00200	95	18.63	17.00	17.50	14.25	16.5	21.2	1.78	15.50	4.63	3/4x8	6.13
PT24207	0279-00201	129	20.50	18.50	19.25	16.50	16.5	21.3	1.84	17.50	4.63	3/4x8	6.13
PT25215	0279-00202	106	18.63	17.00	17.50	14.25	19.3	24.0	1.78	15.50	4.13	3/4x8	6.65
PT25215	0279-00203	137	20.50	18.50	19.25	16.50	19.3	24.0	1.84	17.50	4.13	3/4x8	6.65
PT26307	0279-00204	142	20.50	18.50	19.25	16.50	28.6	33.3	1.84	17.50	4.50	3/4x8	7.31
PT27315	0279-00205	206	22.50	19.00	21.25	16.50	32.5	37.2	2.50	19.25	4.75	1x9	7.81
PT28407	0279-00206	206	22.50	19.00	21.25	16.50	31.6	36.1	2.50	19.25	4.75	1x9	8.81

DOWNLOAD AVAILABLE CAD MODELS AT: WWW.HUBCITYINC.COM

Certified prints are available upon request

EMAIL: hubsales@regalbeloit.com • www.hubcityinc.com



Hub City PowerTorque® Shaft Mount Reducers Accessories

Horizontal Motor Mounts



- All-Steel construction for rigidity
- Compact design eliminates need for motor base
- Top plate adjusts for easy tensioning of drive belt
- Mounting holes provided match NEMA standards

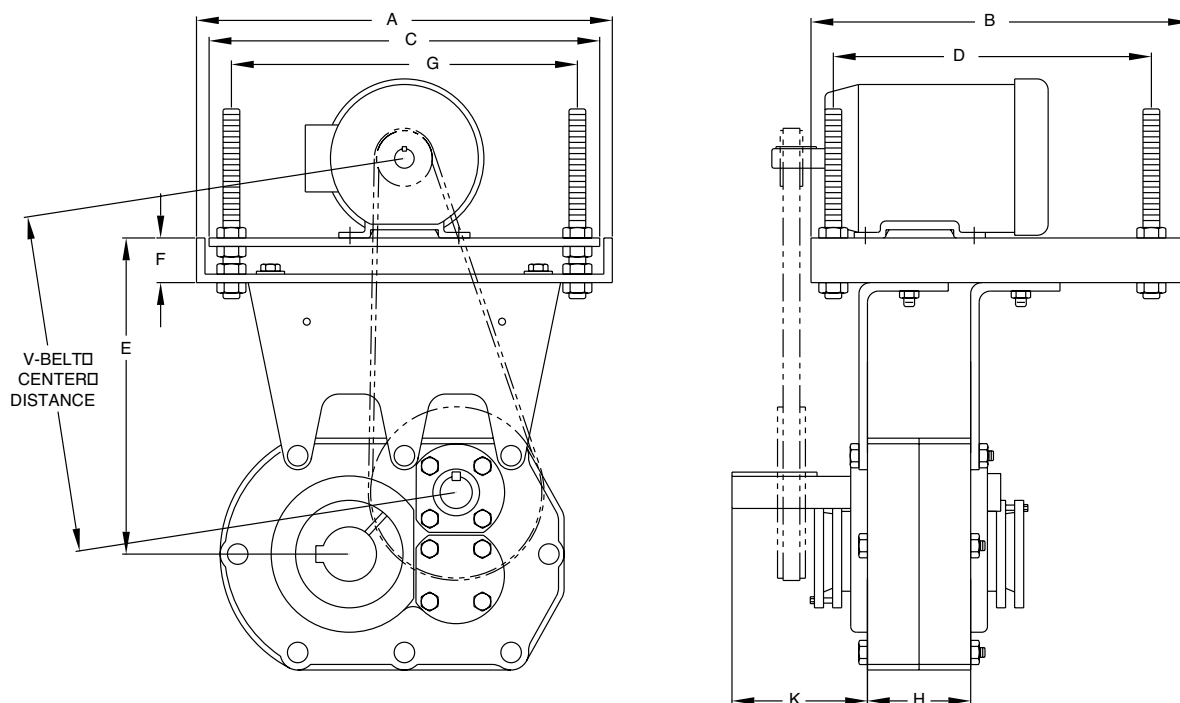

NOTE: SHIELDS/GUARDS NOT SHOWN FOR ILLUSTRATION PURPOSES

DOWNLOAD AVAILABLE CAD MODELS AT: WWW.HUBCITYINC.COM

Certified prints are available upon request

CALL: (605) 225-0360 • FAX: (605) 225-0567

Hub City PowerTorque® Shaft Mount Reducers

Accessories

Horizontal Motor Mounts

HORIZONTAL MOTOR MOUNTS				V-BELT CENTER DISTANCE FOR NEMA MOTOR FRAMES													
SHAFT MOUNT	PART NUMBER	NEMA MOTOR	SCREW DIAMETERS	56-140 MIN	56-140 MAX	180 MIN	180 MAX	210 MIN	210 MAX	250 MIN	250 MAX	280 MIN	280 MAX	320 MIN	320 MAX	360 MIN	360 MAX
PT21107	0279-00270	56C-215T	6 - 12	13.5	17.0	14.5	18	15.3	19.0								
PT22115	0279-00271	56C-215T	6 - 14	14.9	18.3	15.9	19.3	16.6	20.0								
PT23203	0279-00272	56C-215T	6 - 16	15.8	19.3	16.8	20.3	17.6	21.0								
PT23203	0279-00273	143T-286T	6 - 16	16.0	19.5	17.0	20.5	17.8	21.2	18.8	22.2	19.6	22.9				
PT24207	0279-00274	143T-286T	9 - 18	16.9	21.0	17.9	22.0	18.6	22.7	19.6	23.7	20.4	24.5				
PT24207	0279-00275	143T-326T	9 - 18	16.9	21.0	17.9	22.0	18.6	22.7	19.6	23.7	20.4	24.5	21.4	25.4		
PT25215	0279-00276	143T-286T	9 - 18	16.6	20.7	17.6	21.7	18.4	22.4	19.4	23.4	20.0	24.2				
PT25215	0279-00277	143T-326T	9 - 18	16.6	20.7	17.6	21.7	18.4	22.4	19.4	23.4	20.0	24.2	21.1	25.2		
PT26307	0279-00278	143T-326T	12 - 20	17.0	21.0	18.0	22.0	18.8	22.8	19.7	23.8	20.5	24.5	21.5	25.5		
PT27315	0279-00279	143T-365T	12 - 20	22.1	25.6	23.1	26.5	23.8	27.3	24.8	28.3	25.6	29.0	26.6	30.0	27.5	31.0
PT28407	0279-00280	143T-365T	NA	16.1	20.6	17.1	21.6	17.9	22.4	18.9	23.4	19.6	24.1	20.6	25.1	21.6	26.1

SHAFT MOUNT	PART NUMBER	WEIGHT (LBS.)	A	B	C	D	E		F	G	H	J	K
							MIN	MAX					
PT21107	0279-00270	39	14.63	11.00	13.50	9.25	11.1	15.3	1.59	12.00	3.38	5/8x7	3.88
PT22115	0279-00271	40	14.63	11.00	13.50	9.25	12.6	16.8	1.59	12.00	3.38	5/8x7	4.18
PT23203	0279-00272	41	14.63	11.00	13.50	9.25	13.8	18.0	1.59	12.00	4.25	5/8x8	4.88
PT23203	0279-00273	83	18.63	17.00	17.50	14.25	14.0	18.2	1.78	15.50	4.25	3/4x8	4.88
PT24207	0279-00274	97	18.63	17.00	17.50	14.25	15.3	20.1	1.78	15.50	4.63	3/4x8	6.13
PT24207	0279-00275	121	20.50	18.50	19.25	16.50	15.3	20.1	1.84	17.50	4.63	3/4x8	6.13
PT25215	0279-00276	95	18.63	17.00	17.50	14.25	15.3	20.1	1.78	15.50	4.13	3/4x8	6.65
PT25215	0279-00277	122	20.50	18.50	19.25	16.50	15.3	20.1	1.84	17.50	4.13	3/4x8	6.65
PT26307	0279-00278	123	20.50	18.50	19.25	16.50	16.7	21.4	1.84	17.50	4.50	3/4x8	7.31
PT27315	0279-00279	148	22.50	19.00	21.25	16.50	17.5	21.7	2.50	19.25	4.75	1x9	7.81
PT28407	0279-00280	148	22.50	19.00	21.25	16.50	18.3	22.8	2.50	19.25	4.75	1x9	7.81

Horizontal Long Motor Mounts

HORIZONTAL LONG MOTOR MOUNTS				V-BELT CENTER DISTANCE FOR NEMA MOTOR FRAMES													
SHAFT MOUNT	PART NUMBER	NEMA MOTOR	SCREW DIAMETERS	56-140 MIN	56-140 MAX	180 MIN	180 MAX	210 MIN	210 MAX	250 MIN	250 MAX	280 MIN	280 MAX	320 MIN	320 MAX	360 MIN	360 MAX
PT21107	0279-00290	56C-215T	14 - 20	19.5	22.9	20.5	23.9	21.2	24.7								
PT22115	0279-00291	56C-215T	16 - 20	20.9	24.3	21.9	25.3	22.6	26.0								
PT23203	0279-00292	56C-215T	18 - 20	21.8	25.3	22.8	26.3	23.6	27.0								
PT23203	0279-00293	143T-286T	18 - 20	22.0	25.5	23.0	26.5	23.8	27.2	24.8	28.2	25.6	28.9				
PT24207	0279-00294	143T-286T	20 - 24	23.2	27.0	24.2	28.0	24.9	28.6	25.9	29.6	26.7	30.4				
PT24207	0279-00295	143T-326T	20 - 24	23.2	27.0	24.2	28.0	24.9	28.6	25.9	29.6	26.7	30.4	27.4	31.4		
PT25215	0279-00296	143T-286T	20 - 24	22.9	26.6	23.9	27.6	24.7	28.4	25.7	29.4	26.4	30.1				
PT25215	0279-00297	143T-326T	20 - 24	22.9	26.6	23.9	27.6	24.7	28.4	25.7	29.4	26.4	30.1	27.1	31.2		
PT26307	0279-00298	143T-326T	24	23.2	27.0	24.2	27.9	24.9	28.7	25.9	29.7	26.7	30.5	27.6	31.4		
PT27315	0279-00299	143T-365T	24	27.3	31.1	28.3	32.1	29.1	32.9	30.1	33.9	30.8	34.7	31.8	35.6	32.7	36.6
PT28407	0279-00300	143T-365T	NA	22.0	26.5	23.0	27.5	23.8	28.3	24.8	29.3	25.5	30.0	26.5	31.0	27.5	32.0

SHAFT MOUNT	PART NUMBER	WEIGHT (LBS.)	A	B	C	D	E		F	G	H	J	K
							MIN	MAX					
PT21107	0279-00290	49	14.63	11.00	13.50	9.25	17.1	21.3	1.59	12.00	3.38	5/8x7	3.88
PT22115	0279-00291	50	14.63	11.00	13.50	9.25	18.6	22.8	1.59	12.00	3.38	5/8x7	4.18
PT23203	0279-00292	51	14.63	11.00	13.50	9.25	19.8	24.0	1.59	12.00	4.25	5/8x8	4.88
PT23203	0279-00293	93	18.63	17.00	17.50	14.25	20.0	24.2	1.78	15.50	4.25	3/4x8	4.88
PT24207	0279-00294	113	18.63	17.00	17.50	14.25	21.3	26.1	1.78	15.50	4.63	3/4x8	6.13
PT24207	0279-00295	129	20.50	18.50	19.25	16.50	21.3	26.1	1.84	17.50	4.63	3/4x8	6.13
PT25215	0279-00296	113	18.63	17.00	17.50	14.25	21.3	26.1	1.78	15.50	4.13	3/4x8	6.65
PT25215	0279-00297	140	20.50	18.50	19.25	16.50	21.3	26.1	1.84	17.50	4.13	3/4x8	6.65
PT26307	0279-00298	143	20.50	18.50	19.25	16.50	22.7	27.4	1.84	17.50	4.50	3/4x8	7.31
PT27315	0279-00299	172	22.50	19.00	21.25	16.50	23.5	27.7	2.50	19.25	4.75	1x9	7.81
PT28407	0279-00300	172	22.50	19.00	21.25	16.50	24.3	28.8	2.50	19.25	4.75	1x9	7.81

DOWNLOAD AVAILABLE CAD MODELS AT: WWW.HUBCITYINC.COM

Certified prints are available upon request

EMAIL: hubsales@regalbeloit.com • www.hubcityinc.com



Hub City PowerTorque® Shaft Mount Reducers

Accessories

Vertical Belt Guards



- All-Steel construction
- Adjustable to fit a wide range of sheaves and motor frames
- Designed for easy installation, no drilling required

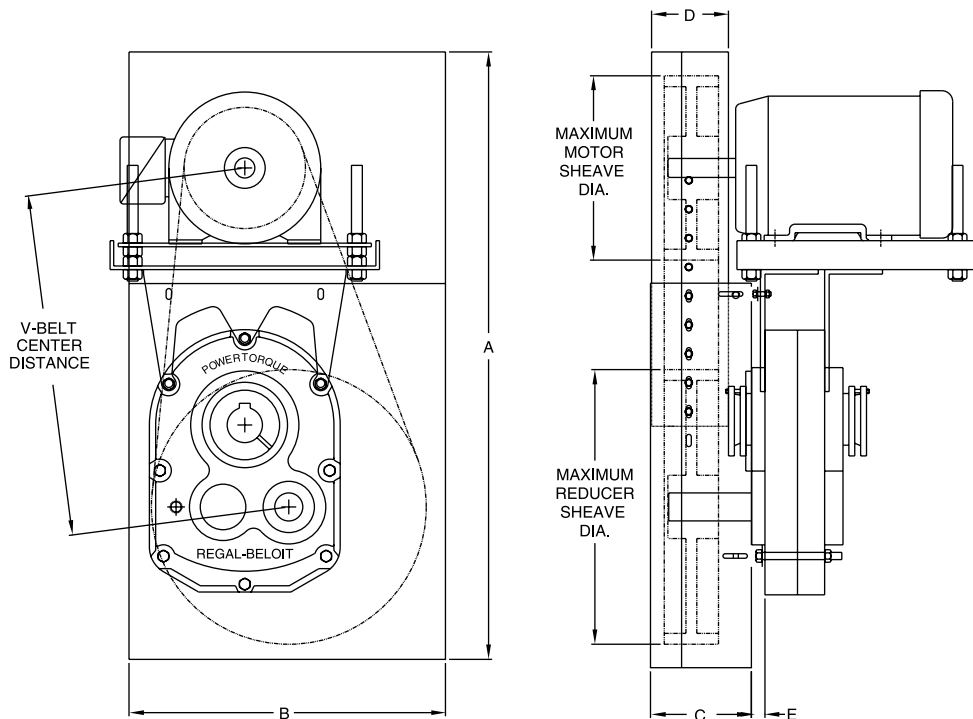

VERTICAL BELT GUARDS													
SHAFT MOUNT MODEL	BELT GUARD PART NUMBER	NEMA MOTOR FRAME	WEIGHT (LBS.)	V-BELT CENTER DISTANCE		MAXIMUM SHEAVE DIA.		A		B	C	D	E
				MIN	MAX	MOTOR	REDUCER	MIN.	MAX.				
PT21107	0279-00371	56C-215T	51	17.6	22.7	6.4	18.0	31.75	39.75	22.00	5.40	4.31	0.56
PT22115	0279-00375	56C-215T	54	18.7	23.9	8.6	19.0	32.75	40.75	22.00	5.40	4.31	0.56
PT23203	0279-00379	56C-286T	57	20.2	27.2	8.6	19.0	35.75	43.75	22.00	5.40	4.31	0.56
PT24207	0279-00383	143T-326T	71	21.2	29.8	12.0	19.0	40.25	48.25	23.50	6.90	5.31	0.63
PT25215	0279-00387	143T-326T	75	22.7	31.2	12.0	19.0	41.75	49.75	23.50	6.90	5.31	0.63
PT26307	0279-00391	143T-326T	104	25.9	34.2	14.0	25.0	48.25	56.25	29.25	8.70	7.44	2.00
PT27315	0279-00395	143T-365T	126	30.6	39.9	14.0	30.0	55.25	63.25	34.25	8.70	7.44	1.25
PT28407	0279-00399	143T-365T	126	31.9	41.2	14.0	30.0	55.25	63.25	34.25	8.70	7.44	1.25

VERTICAL LONG BELT GUARDS													
SHAFT MOUNT MODEL	BELT GUARD PART NUMBER	NEMA MOTOR FRAME	WEIGHT (LBS.)	V-BELT CENTER DISTANCE		MAXIMUM SHEAVE DIA.		A		B	C	D	E
				MIN	MAX	MOTOR	REDUCER	MIN.	MAX.				
PT21107	0279-00372	56C-215T	55	20.6	25.7	6.4	18.0	34.50	42.50	22.00	5.40	4.31	0.56
PT22115	0279-00376	56C-215T	57	21.7	26.9	8.6	19.0	35.50	43.50	22.00	5.40	4.31	0.56
PT23203	0279-00380	56C-286T	60	23.2	30.2	8.6	19.0	38.75	46.75	22.00	5.40	4.31	0.56
PT24207	0279-00384	143T-326T	82	25.7	34.3	12.0	19.0	44.50	52.50	23.50	6.90	5.31	0.63
PT25215	0279-00388	143T-326T	80	29.5	37.9	12.0	19.0	48.00	56.00	23.50	6.90	5.31	0.63
PT26307	0279-00392	143T-326T	123	39.9	48.2	14.0	25.0	62.25	70.25	29.25	8.70	7.44	2.00
PT27315	0279-00396	143T-365T	150	45.6	54.9	14.0	30.0	71.00	79.00	34.25	8.70	7.44	1.25
PT28407	0279-00400	143T-364T	150	44.9	54.3	14.0	30.0	71.00	79.00	34.25	8.70	7.44	1.25

DOWNLOAD AVAILABLE CAD MODELS AT: WWW.HUBCITYINC.COM

Certified prints are available upon request

CALL: (605) 225-0360 • FAX: (605) 225-0567

Hub City PowerTorque® Shaft Mount Reducers

Accessories

Horizontal Belt Guards

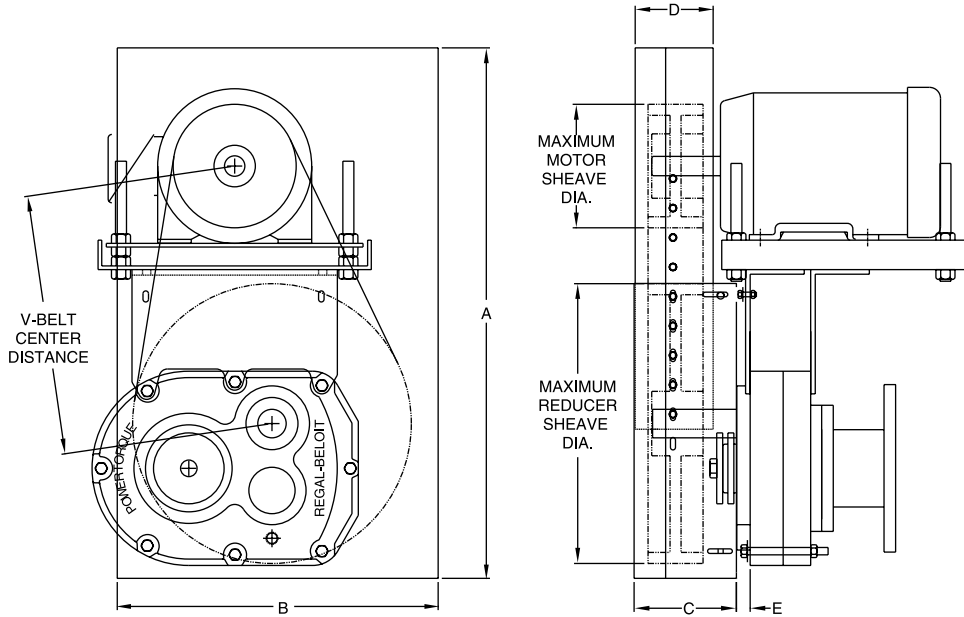

- All-Steel construction
- Adjustable to fit a wide range of sheaves and motor frames
- Designed for easy installation, no drilling required

PowerTorque® Shaft Mount Reducers



HORIZONTAL BELT GUARDS													
SHAFT MOUNT MODEL	BELT GUARD PART NUMBER	NEMA MOTOR FRAME	WEIGHT (LBS.)	V-BELT CENTER DISTANCE		MAXIMUM SHEAVE DIA.		A		B	C	D	E
				MIN	MAX	MOTOR	REDUCER	MIN.	MAX.				
PT21107	0279-00373	56C-215T	48	13.5	19.0	6.4	18.0	27.75	35.75	22.00	5.40	4.31	0.56
PT22115	0279-00377	56C-215T	51	14.9	20.0	8.6	19.0	28.75	36.75	22.00	5.40	4.31	0.56
PT23203	0279-00381	56C-286T	53	15.8	22.9	8.6	19.0	31.50	39.50	22.00	5.40	4.31	0.56
PT24207	0279-00385	143T-326T	67	16.9	25.4	12.0	19.0	36.25	44.25	23.50	6.90	5.31	0.63
PT25215	0279-00389	143T-326T	64	16.6	25.2	12.0	19.0	35.75	43.75	23.50	6.90	5.31	0.63
PT26307	0279-00393	143T-326T	92	17.0	25.5	14.0	25.0	39.50	47.50	29.25	8.70	7.44	2.00
PT27315	0279-00397	143T-365T	105	22.1	31.0	14.0	30.0	41.75	49.75	34.25	8.70	7.44	1.25
PT28407	0279-00401	143T-365T	105	16.1	25.4	14.0	30.0	41.75	49.75	34.25	8.70	7.44	1.25

HORIZONTAL LONG BELT GUARDS													
SHAFT MOUNT MODEL	BELT GUARD PART NUMBER	NEMA MOTOR FRAME	WEIGHT (LBS.)	V-BELT CENTER DISTANCE		MAXIMUM SHEAVE DIA.		A		B	C	D	E
				MIN	MAX	MOTOR	REDUCER	MIN.	MAX.				
PT21107	0279-00374	56C-215T	53	19.5	24.7	6.4	18.0	33.75	41.75	22.00	5.40	4.31	0.56
PT22115	0279-00378	56C-215T	56	20.9	26.0	8.6	19.0	34.75	42.75	22.00	5.40	4.31	0.56
PT23203	0279-00382	56C-286T	59	21.8	28.9	8.6	19.0	37.25	45.25	22.00	5.40	4.31	0.56
PT24207	0279-00386	143T-326T	73	23.2	31.4	12.0	19.0	41.50	49.50	23.50	6.90	5.31	0.63
PT25215	0279-00390	143T-326T	73	22.9	31.2	12.0	19.0	42.00	50.00	23.50	6.90	5.31	0.63
PT26307	0279-00394	143T-326T	100	23.2	31.4	14.0	25.0	45.50	53.50	29.25	8.70	7.44	2.00
PT27315	0279-00398	143T-365T	115	27.3	36.6	14.0	30.0	48.00	56.00	34.25	8.70	7.44	1.25
PT28407	0279-00402	143T-365T	115	22.0	31.4	14.0	30.0	48.00	56.00	34.25	8.70	7.44	1.25

Cooling Fans

Available upon request, consult factory for details

DOWNLOAD AVAILABLE CAD MODELS AT: WWW.HUBCITYINC.COM

Certified prints are available upon request

EMAIL: hubsales@regalbeloit.com • www.hubcityinc.com



Hub City PowerTorque® Shaft Mount Reducers

Accessories

Screw Conveyor Drive

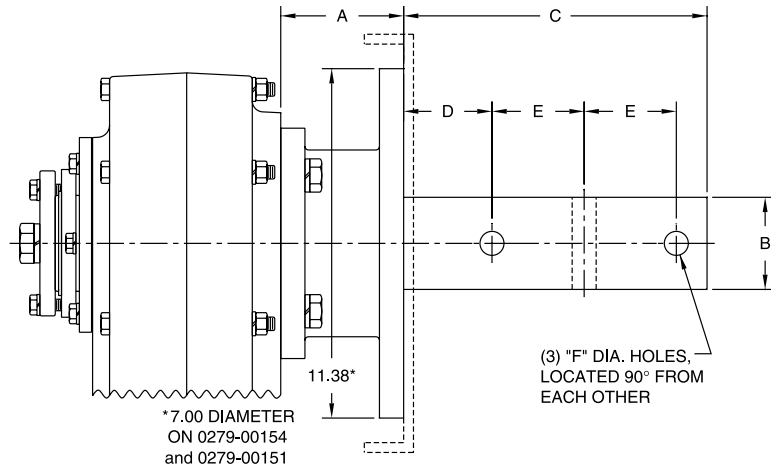

SHAFT MOUNT MODEL	ADAPTOR FLANGES			DRIVE SHAFTS							
	PART NUMBER	WEIGHT (LBS.)	A	PART NUMBER	WEIGHT (LBS.)	B	C	D	E	F	SCREW SIZE
PT21107	0279-00151	13	3.22	0279-00211	14	1.500	9.00	2.12	3.00	17/32	6
				0279-00212	17	2.000	9.00	2.12	3.00	21/32	9, 12
	0279-00152	27	3.22	0279-00213	22	2.437	9.69	2.75	3.00	21/32	12, 14
				0279-00214	29	3.000	9.88	2.88	3.00	25/32	12 - 20
				0279-00215	15	1.500	9.00	2.12	3.00	17/32	6
PT22115	0279-00154	15	3.56	0279-00215	15	1.500	9.00	2.12	3.00	17/32	6
				0279-00216	18	2.000	9.00	2.12	3.00	21/32	9, 12
	0279-00153	25	3.56	0279-00217	23	2.4375	9.69	2.75	3.00	21/32	12, 14
				0279-00218	30	3.000	9.88	2.88	3.00	25/32	12 - 20
PT23203	0279-00155	29	3.69	0279-00219	20	1.500	9.00	2.12	3.00	17/32	9
				0279-00220	23	2.000	9.00	2.12	3.00	21/32	9, 12
				0279-00221	28	2.4375	9.69	2.75	3.00	21/32	12, 14
				0279-00222	35	3.000	9.88	2.88	3.00	25/32	12 - 20
				0279-00223	24	1.500	9.00	2.12	3.00	17/32	9
PT24207	0279-00156	33	4.00	0279-00224	27	2.000	9.00	2.12	3.00	21/32	9, 12
				0279-00225	32	2.4375	9.69	2.75	3.00	21/32	12, 14
				0279-00226	39	3.000	9.88	2.88	3.00	25/32	12 - 20
				0279-00227	53	3.4375	13.13	3.88	4.00	29/32	18 - 24
				0279-00228	37	2.000	9.00	2.12	3.00	21/32	9, 12
PT25215	0279-00157	43	4.25	0279-00229	42	2.4375	9.69	2.75	3.00	21/32	12, 14
				0279-00230	49	3.000	9.88	2.88	3.00	25/32	12 - 20
				0279-00231	63	3.4375	13.13	3.88	4.00	29/32	18 - 24
				0279-00232	57	2.4375	9.69	2.75	3.00	21/32	12, 14
PT26307	0279-00158	56	5.50	0279-00233	64	3.000	9.88	2.88	3.00	25/32	12 - 20
				0279-00234	78	3.4375	13.13	3.88	4.00	29/32	18 - 24
				0279-00235	73	2.4375	9.69	2.75	3.00	21/32	12, 14
PT27315	0279-00159	72	6.50	0279-00236	80	3.000	9.88	2.88	3.00	25/32	12 - 20
				0279-00237	94	3.4375	13.13	3.88	4.00	29/32	18 - 24

Adapter Flanges

Conform to CEMA standards. Bolt-on design allows easy mounting. Open center for contaminate dropout.



Drive Shafts

Conform to CEMA dimensional standards. Machined from high strength alloy steel. Easy installation into standard hollow bore.



Auxiliary Seal Kits

Available upon request, consult factory for details

DOWNLOAD AVAILABLE CAD MODELS AT: WWW.HUBCITYINC.COM

Certified prints are available upon request

CALL: (605) 225-0360 • FAX: (605) 225-0567

Warnings & Cautions, Lubrication & Installation Instructions



Mechanical Warnings & Cautions - Gear Drives	S-3
PowerTorque® Shaft Mount Reducers	S-4
330 Series Pump Drive	S-6
Gear Lubricants.....	S-7
Mounted Bearing Warnings & Cautions.....	S-8
IndustriaLine™ and DuraLine™ Mounted Bearings	S-10
CleanLine UltraPlus™, and CleanLine Plus™ Mounted Bearings	S-11
ModuLine™ Spherical Roller Bearings	S-12
HubFlex™ Coupling Installation	S-14
Terms and Conditions of Sale.....	T-1

Warnings & Cautions, Lubrication & Installation Instructions



IMPORTANT INFORMATION! PLEASE READ CAREFULLY



The following  and  information is supplied to you for your protection and to provide you with many years of trouble free and safe operation of your HUB CITY product.

Read ALL instructions prior to operating reducer. Injury to personnel or reducer failure may be caused by improper installation, maintenance or operation.



- Written authorization from HUB CITY is required to operate or use reducers in man lift or people moving devices.
- Check to make certain application does not exceed the allowable load capacities published in the current catalog.
- Buyer shall be solely responsible for determining the adequacy of the product for any and all uses to which Buyer shall apply the product. The application by Buyer shall not be subject to any implied warranty of fitness for a particular purpose.
- For safety, Buyer or User should provide protective guards over all shaft extensions and any moving apparatus mounted thereon. The User is responsible for checking all applicable safety codes in his area and providing suitable guards. Failure to do so may result in bodily injury and/or damage to equipment.
- Hot oil and reducers can cause severe burns. Use extreme care when removing lubrication plugs and vents.
- Make certain that the power supply is disconnected before attempting to service or remove any components. Lock out the power supply and tag it to prevent unexpected application of power.
- Reducers are not to be considered fail safe or self-locking devices. If these features are required, a properly sized, independent holding device should be utilized. Reducers should not be used as a brake.
- Any brakes that are used in conjunction with a reducer must be sized or positioned in such a way so as to not subject the reducer to loads beyond the catalog rating.
- Lifting supports including eyebolts are to be used for vertically lifting the gearbox only and no other associated attachments or motors.
- Use of an oil with an EP additive on units with backstops may prevent proper operation of the backstop. Injury to personnel, damage to the reducer or other equipment may result.
- Overhung loads subject shaft bearings and shafts to stress which may cause premature bearing failure and/or shaft breakage from bending fatigue, if not sized properly.



- Test run unit to verify operation. If the unit tested is a prototype, that unit must be of current production.
- If the speed reducer cannot be located in a clear and dry area with access to adequate cooling air supply, then precautions must be taken to avoid the ingestion of contaminants such as water and the reduction in cooling ability due to exterior contaminants.
- Mounting bolts should be routinely checked to ensure that the unit is firmly anchored for proper operation.

In the event of the resale of any of the goods, in whatever form, Resellers/Buyers will include the following language in a conspicuous place and in a conspicuous manner in a written agreement covering such sale:

The manufacturer makes no warranty or representations, express or implied, by operation of law or otherwise, as to the merchantability or fitness for a particular purpose of the goods sold hereunder. Buyer acknowledges that it alone has determined that the goods purchased hereunder will suitably meet the requirements of their intended use. In no event will the manufacturer be liable for consequential, incidental or other damages. Even if the repair or replacement remedy shall be deemed to have failed of its essential purpose under Section 2-719 of the Uniform Commercial Code, the manufacturer shall have no liability to Buyer for consequential damages.

Resellers/Buyers agree to also include this entire document including the warnings and cautions above in a conspicuous place and in a conspicuous manner in writing to instruct users on the safe usage of the product.

This information should be read together with all other printed information supplied by HUB CITY.

Warnings & Cautions, Lubrication & Installation Instructions

Gear Drive Warnings & Cautions

IMPORTANT SELECTION INFORMATION

The system of connected rotating parts must be free from critical speed, torsional, or other type vibration, regardless of how induced. The responsibility for this system analysis lies with the purchaser of the gear unit.



SHIELD ALL ROTATING PARTS

For safety, purchaser or user must provide protective guards over all shaft extensions and any moving apparatus mounted on the unit. The user is responsible for checking and complying with all applicable safety codes in his area and providing suitable guards. Failure to do so may result in bodily injury and/or damage to equipment.



Wear protective clothing and eye shields when installing or maintaining unit and machine.



A unit cannot be used as an integral part of a machine superstructure which would impose additional loads on the unit other than those imposed by the torque being transmitted, or by any shaft mounted power transmitting device such as sprockets, pulleys, or couplings.



Make certain that all tools and other items are clear from rotating parts before starting machine. Stand clear, and start machine slowly to be sure all components are secure and operating properly.



For safe operation and to continue the unit warranty, when installing, reinstalling, or replacing a factory installed fastener for servicing purpose, or to accommodate the mounting of guards, shields or other light load imposing devices, or for mounting the unit, it becomes the responsibility of the purchaser or user to properly determine the quality, grade of fastener, thread engagement, load carrying capacity, tightening torque, and the means of torque retention.

COUPLINGS — Flexible couplings to input and output shafts are recommended because they minimize bearing and gear wear caused by slight misalignment. Follow coupling manufacturer's recommendations for installation and shielding.

SHEAVES AND SPROCKETS — When mounting sheaves or sprockets, the center of the load should be located as close to the reducer as possible. Excessive overhung loading could result in early failures of bearing or shaft. Refer to the general catalog or contact Hub City for overhung load ratings. Follow manufacturer's recommendations for installation and shielding.



Do not operate the unit without making sure it contains the correct amount of oil. Do not overfill or underfill with oil, or injury to personnel, unit, or other equipment may result.



Oil should be changed with greater frequency if unit is used in a severe environment such as dusty or humid or high or low temperatures.



Do not mix nonsynthetic and synthetic oil in the unit.



If unit is used in the food or drug industry (including animal food) consult the petroleum supplier or HUB CITY for recommendations of lubricants which meet the specifications of FDA, USDA and/or other authoritative bodies having jurisdiction. Standard lubricants are not suitable for these applications or these industries.



Inspect shafts and components for paint, burrs, or other imperfections before installing components. Do not use excessive force or pounding to install components onto unit shafts, as this may cause damage to shafts, bearings, or gears.

PREVENTATIVE MAINTENANCE — Keep shafts and vent plug clean to prevent foreign particles from entering seals or gear case. Inspect periodically for oil leaks.



STORAGE OF HUB CITY REDUCERS: A gearbox does not have a definable shelf life. The main points of deterioration are rusting of non-painted surfaces and drying out of the seal lips. Proper storage of drives in a cool dry place in a carton away from exposure to ultraviolet light should permit protection for approximately one year.

If the unit is to be inoperative for a longer period of time, completely fill the gear case with regular lubricant containing rust and oxidation inhibitors, tag the gear case and any connected motor to prevent operation until the proper oil level is obtained. Do not operate a completely filled gear case. Coat external shafts with a rust preventative oil or grease. At least every three months, rotate the input shaft until the output rotates at least one revolution to ensure all internal parts are coated and that the shaft seals are free and the seal journals are coated with oil.

The most sensitive part of the gearbox is the radial lip seals. Even under ideal storage conditions, the seal lips may deteriorate or take a set, losing their sealing effect and reducing service life. Therefore, it may be necessary to replace the seals prior to putting the units in service depending upon the length and conditions of storage.

Warnings & Cautions, Lubrication & Installation Instructions

PowerTorque® Shaft Mount Reducers

LUBRICATION



ALL POWERTORQUE® SHAFT MOUNT REDUCERS ARE SHIPPED DRY AND OIL MUST BE ADDED PRIOR TO OPERATION.

BEFORE INSTALLATION: All Hub City PowerTorque® Shaft Mount Reducers are splash lubricated. Review the mounting positions and lubrication levels identified in Figure SM1.

Below 15 RPM output speed, the oil level must be adjusted to reach the highest oil level plug. If the reducer mounting position is to vary from the positions shown in Figure SM1, either more or less oil may be required. Consult HUB CITY for recommendations.

BEFORE OPERATING PowerTorque® Shaft Mount Reducers: After final installation, install the magnetic drain plug in the drain location specified in Figure SM1. Remove the fill/vent plug and level plug. Fill the reducer with recommended lubricant (see APPROXIMATE OIL CAPACITY CHART in these instructions and GEAR LUBRICANT page of these instructions) until oil starts coming out the oil level plug hole specified in Figure SM1. Clean threads on removed plugs and plug holes with degreaser, coat plugs with thread sealant and install plugs securely in gear case. Install the vent plug in the location specified in Figure SM1 for the appropriate mounting position. Remove the tape used to cover the vent plug during shipment and discard.



The oil level is correct when the surface of the oil is level with the lowest point of the level plug shown in Figure SM1.

VARIATIONS FROM NORMAL CONDITIONS -

PowerTorque® Shaft Mount Reducers: Input speeds that exceed the maximum speeds recommended for a given ratio, which are listed in the general catalog specifications, may require an adjustment in the oil level. Consult HUB CITY for special lubricant recommendations when operating at higher speeds.

Hub City PowerTorque® Shaft Mount Reducers may be mounted in any of the positions shown in Figure SM1. These positions may vary up to 5° for positions “A” or “C” and 20° for positions “B” or “D” in either direction and still have adequate lubrication. If these angles of inclination are exceeded consult HUB CITY for special lubrication instructions. Because mounting positions can vary greatly along with the location and availability of plugs in certain applications,

it may be necessary to install additional plugs as needed or level gages in place of level plugs.



CHANGING LUBRICANT — After the first 100 hours of operation, drain out initial oil, flush out the PowerTorque® gear case with an approved nonflammable, non-toxic solvent, such as Lubriplate Syn Flush, Lubriplate Pure Flush, Whitmore’s Flushing Oil (#06802030) or Medallion™ Flushing Oil Kosher (#06812010), and refill. Thereafter, oil should be changed at least every 5,000 operating hours (10,000 for synthetic oil lubricant) or every 12 months (24 months for synthetic oil lubricant), which ever occurs first.



Do not use GL-90, 75W-90 or other extreme pressure (EP) lubricants containing friction modifiers such as graphite or molybdenum disulfide in gear drives containing internal backstops. Lubricants with EP additives may produce coatings which adversely affect operation of the backstop. Injury to personnel, damage to the reducer or other equipment may result.

POWER TORQUE SHAFT MOUNT REDUCERS Approximate Oil Capacities (pints)

MODEL	MOUNTING POSITION					
	HORIZONTAL SHAFTS				VERTICAL SHAFTS	
	A	B	C	D	E	F
PT21107	1.0	1.0	1.3	1.5	2.0	2.5
PT22115	1.8	2.0	1.3	2.0	3.3	3.5
PT23203	3.0	3.0	1.5	4.5	5.3	6.0
PT24207	3.8	4.5	2.5	6.0	6.8	8.5
PT25215	6.5	5.0	6.5	5.0	14.0	17.3
PT26307	8.5	10.0	8.5	10.0	17.3	18.3
PT27315	13.0	16.0	14.5	18.5	30.8	32.8
PT28407	17.0	22.0	21.0	17.0	38.3	38.3
PT29415	26.0	26.0	25.0	28.5	50.8	50.8
PT210507	46.0	28.0	31.5	37.5	82.0	82.0

MOUNTING POSITIONS FIGURE - SM1

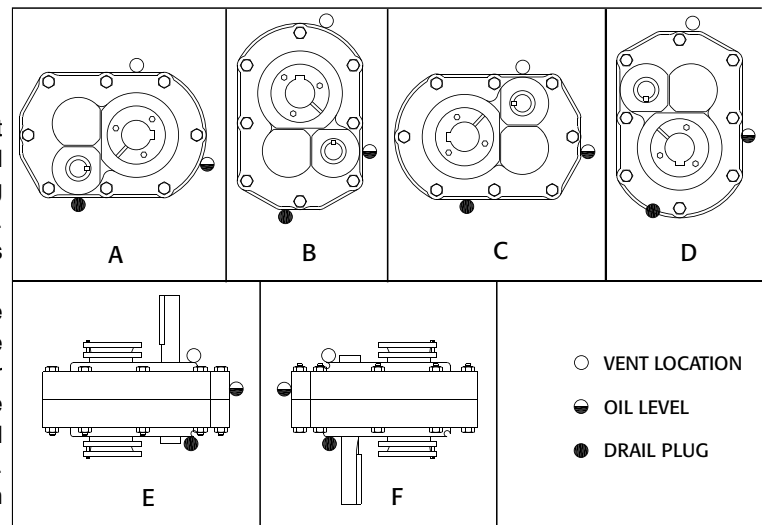

Warnings & Cautions, Lubrication & Installation Instructions

PowerTorque® Shaft Mount Reducers

INSTALLATION

The lifting eye included on this drive is to be used to vertically lift the drive only and no other associated attachments or motors.



For high momentum loads, if coasting to a stop is undesirable, a braking mechanism should be applied to the reducer output or driven mechanism.



1. INSTALL REDUCER ON DRIVEN SHAFT

The driven shaft must extend through the full length of the reducer sleeve and the shaft should be independently supported with pillow block bearings located as close to the reducer as possible. The driven shaft must be installed in the sleeve with a bushing at each end. Refer to installation instructions provided with tapered bushings.

2. INSTALL TORQUE ARM

The Torque Arm must be installed on shaft mounted reducers to prevent the unit from rotating. Install and position the Torque Arm at a 90° angle to a line drawn through the center of the low speed sleeve and the bolt that attaches the Torque Arm to the Torque Arm brackets on the unit. (Refer to Figure SM2). The Torque Arm should be positioned to be in tension, NOT compression, based on output rotation of the gear reducer. A rigid Torque Arm can cause bearings to “load up” and cause premature bearing failure. To prevent this, provide a slight amount of “float” at the torque arm pivot points.

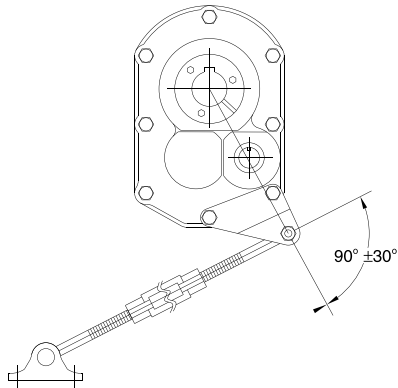

FIGURE SM2

3. INSTALL SHEAVES AND SPROCKETS

When mounting sheaves or sprockets, they should be located as close to the Gear Drive as possible. Excessive overhung load could result in premature failures of bearings or shaft. Refer to the general catalog or contact your local distributor for overhung load ratings.

4. INSTALL MOTOR AND V-BELT DRIVE

Install the motor and V-belt drive with the V-belt at a right angle approximately to the centerline between the driven and input shaft. This will allow using the torque arm to tighten the V-belt. (See Figure SM3.)

If using a motor mount that is installed directly to the reducer, refer to the Installation Instructions provided with the motor mount.

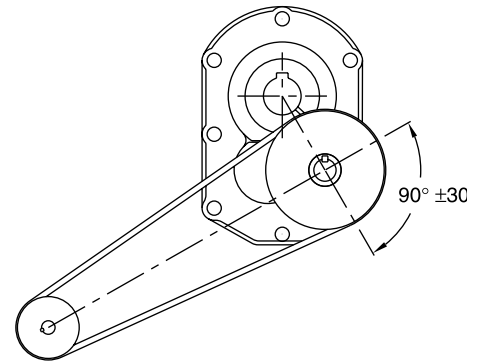

FIGURE SM3



SHIELD ALL ROTATING PARTS

For safety, purchaser or user should provide protective shields over the V-belt drive, all shaft extensions and any moving apparatus mounted on the unit. The user is responsible for checking all applicable safety codes in his area and providing suitable guards. Failure to do so may result in bodily injury and/or damage to equipment.

5. FILL REDUCER WITH LUBRICANT

Refer to the PowerTorque® Shaft Mount Reducers Lubrication section for recommended lubricants and oil levels for the various mounting positions.



FLANGE MOUNTED PowerTorque® Shaft Mount Reducers: Units with the flange mount accessory are to be mounted and supported by the mounting flange only. The mounting pads on the housing are not to be used in conjunction with the mounting flange to support the unit.

SHAFT MOUNTED PowerTorque® Shaft Mount Reducers WITH MOUNTING FLANGE:

There must be concentricity between the driven shaft and the machine register that accepts the mounting flange pilot to prevent misalignment between the hollow shaft of the drive and the driven shaft.

SHAFT OUTPUT PowerTorque® Shaft Mount Reducers WITH MOUNTING FLANGE: If coupling to shaft – flexible couplings are recommended to minimize excessive bearing and shaft loading caused by misalignment. Follow coupling manufacturer's installation directions.

Warnings & Cautions, Lubrication & Installation Instructions

330 Pump Drive

MODEL 330 PUMP DRIVE LUBRICATION



ALL MODEL 330 PUMP DRIVES ARE SHIPPED DRY.

Oil must be added prior to operation. Hub City 330 Pump Drive units are splash lubricated and require 1.25 pints to fill to the recommended level. Do not overfill – this causes excessive heat build-up. See Figures PD1 & PD2 for fill and level check points.

BEFORE OPERATING 330 Pump Drive — Remove uppermost plug and fill Reducer with a recommended lubricant (see GEAR LUBRICANT page of these instructions). Clean threads on removed plugs and plug holes with degreaser; coat with thread sealant and install securely into Reducer case. If fill, level and drain plugs are not located conveniently for your mounting position, additional plugs may be installed. Consult HUB CITY for recommendations.

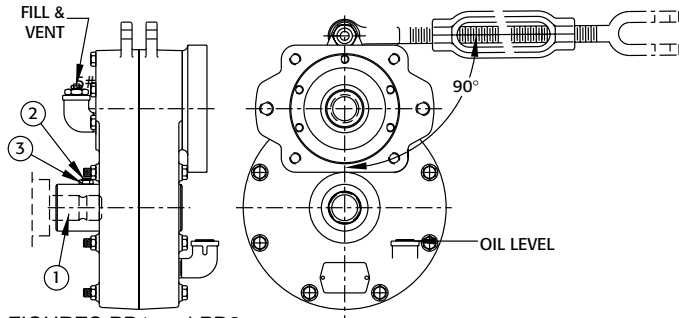

FIGURES PD1 and PD2



VARIATIONS FROM NORMAL CONDITIONS

— Model 330 Pump Drive: When operating High Speed Shaft at speeds above 1800 RPM or below 400 RPM, special adjustment in oil level may be required. Consult HUB CITY for recommendations.

If either shaft is in a vertical position or inclined more than 15°, zerk fittings may be required to lubricate upper bearings. It may also be necessary to make some oil level or plug modifications. Consult HUB CITY for recommendations.



CHANGING LUBRICANT — After the first 100 hours of operation, drain out initial oil, flush out the 330 pump drive gear case with an approved nonflammable, non-toxic solvent, such as Lubriplate Syn Flush, Lubriplate Pure Flush, Whitmore's Flushing Oil (#06802030) or Medallion™ Flushing Oil Kosher (#06812010), and refill. Thereafter, oil should be changed at least every 5,000 operating hours (10,000 for synthetic oil lubricant) or every 12 months (24 months for synthetic oil lubricant), whichever occurs first.

MODEL 330 PUMP DRIVE INSTALLATION

IMPORTANT: Check tractor PTO shaft for nicks and burrs.

Slide the pump drive onto the PTO shaft (1, Figure PD1). Center the setscrews over the groove in the PTO shaft. With a torque wrench tighten setscrews (2, Figure PD1) to 300 in-lb (25 ft-lb). Torque jam nuts (3, Figure PD1) to 120 in-lb torque. Pump drive should be mounted with SAE pump flange directly above the PTO shaft.



TORQUE ARM:

It is recommended that torque arm be fabricated from flat cold-rolled steel (800 lbs. capacity, compression or tension). It must be a minimum of 3/4" wide and 1/2" thick. Torque arm must be able to swivel in both torque arm housing bracket and pivot bracket mounted on tractor.

Connection of the torque arm to the pivot bracket should be made with a 3/8" heat-treated bolt with double jam nuts. Connection of the torque arm to the pump drive housing bracket should be made in the same manner. Torque arm should be mounted at 90° (or as close to 90° as possible) to a line between the tractor PTO shaft and gearbox torque arm housing bracket. (See Figure PD2.)

NOTE: Flexibility in torque arm connection is necessary to prevent undue load on pump drive and shaft. Stress is placed on housing if torque arm is clamped too tightly.

Warnings & Cautions, Lubrication & Installation Instructions Hub City Gear Lubricant

RECOMMENDED LUBRICANTS		
		
HUB CITY UNIT	GL-90 8580001009	SYNTHETIC 75W-90 8580001031
POWERTORQUE®	X	X
330 SERIES PTO Pump Drive	X	X

GEAR LUBRICANT

GL-90

Part No. 8580001009(Qt.)

AGMA No: 5EP

ISO Viscosity Grade: 220

A non-leaded, heavy-duty industrial gear lubricant designed for spur, helical, and bevel enclosed gear sets operating under severe service conditions. Ideal for both circulation and splash lubrication systems, GL-90 offers:

- Superior load-carrying capacity.
- Outstanding anti-wear properties.
- Excellent rust and corrosion protection.
- Good oxidation stability.
- Minimal friction and bulk oil temperature rise.
- Full protection against foaming.

For ambient temperatures of 15° to 125° F (-10° to 52° C) and operating temperatures To 185° F (85° C).

For ambient temperatures below or above these temperatures, or operating temperatures above this temperature, consult the factory.

GEAR LUBRICANT

SYNTHETIC 75W-90

Part No. 8580001031(Qt.)

AGMA No: 4/5EP

ISO Viscosity Grade: 150/220

Formulated from synthesized hydrocarbon base oils and a sulfur phosphorus gear lubricant additive for severe operating conditions. Recommended for bevel, helical, and spur gear drives. Especially those subject to low startup temperature and/or high operating temperature. It provides the following outstanding advantages and benefits.

- Excellent wear protection and load carrying ability.
- Outstanding oxidation stability at elevated temperatures.
- Wide temperature range.
- Extend lubricant life resulting in lower maintenance and lubrication costs.
- Recommended for year-round lubrication.
- Not recommended for worm gear drives or gear drives with backstops.

The outstanding oxidation and thermal stability of this product results in a considerable extension of lubrication and oil change intervals.

For ambient temperatures of -25° to 125° F (-32° to 52° C) and operating temperatures To 225° F (107° C).

For ambient temperatures below or above these temperatures, or operating temperatures above this temperature, consult the factory.

Hub City synthetic 75W-90 gear lubricant can be operated at temperatures above 225° F however, the gear drive manufacturer should always be contacted prior to operation at high temperatures. As damage may occur to seals or other gear drive components. Although Hub City synthetic 75W-90 lubricant is fully compatible with conventional lubricants, maximum benefits will be obtained when installed in a system which has been thoroughly cleaned and flushed.





Warnings & Cautions, Lubrication & Installation Instructions



IMPORTANT INFORMATION! PLEASE READ CAREFULLY



The following  and  information is supplied to you for your protection and to provide you with many years of trouble free and safe operation of your HUB CITY mounted bearing product.

Read ALL instructions prior to operating reducer. Injury to personnel or reducer failure may be caused by improper installation, maintenance or operation.



- Written authorization from HUB CITY is required to operate or use bearing units in man lift or people moving devices.
- Check to make certain application does not exceed the allowable load capacities published in the current catalog.
- Buyer shall be solely responsible for determining the adequacy of the product for any and all uses to which Buyer shall apply the product. The application by Buyer shall not be subject to any implied warranty of fitness for a particular purpose.
- For safety, Buyer or User should provide protective guards over all shaft extensions and any moving apparatus mounted thereon. The User is responsible for checking all applicable safety codes in his area and providing suitable guards. Failure to do so may result in bodily injury and/or damage to equipment.
- Hot machinery and bearings can cause severe burns. Use extreme care when servicing or lubricating.
- Make certain that the power supply is disconnected before attempting to service or remove any components. Lock out the power supply and tag it to prevent unexpected application of power.
- Lifting supports including eyebolts are to be used for vertically lifting the bearing unit only and no other associated attachments or motors.
- Overhung loads subject shaft bearings and shafts to stress which may cause premature bearing failure and/or shaft breakage from bending fatigue, if not sized properly.



- Test run bearing unit to verify operation. If the unit tested is a prototype, that unit must be of current production.
- If the bearing unit cannot be located in a clear and dry area with access to adequate cooling air supply, then precautions must be taken to avoid the ingestion of contaminants such as water and the reduction in cooling ability due to exterior contaminants.
- Mounting bolts should be routinely checked to ensure that the bearing unit is firmly anchored for proper operation.

In the event of the resale of any of the goods, in whatever form, Resellers/Buyers will include the following language in a conspicuous place and in a conspicuous manner in a written agreement covering such sale:

The manufacturer makes no warranty or representations, express or implied, by operation of law or otherwise, as to the merchantability or fitness for a particular purpose of the goods sold hereunder. Buyer acknowledges that it alone has determined that the goods purchased hereunder will suitably meet the requirements of their intended use. In no event will the manufacturer be liable for consequential, incidental or other damages. Even if the repair or replacement remedy shall be deemed to have failed of its essential purpose under Section 2-719 of the Uniform Commercial Code, the manufacturer shall have no liability to Buyer for consequential damages.

Resellers/Buyers agree to also include this entire document including the warnings and cautions above in a conspicuous place and in a conspicuous manner in writing to instruct users on the safe usage of the product.

This information should be read together with all other printed information supplied by HUB CITY.

Warnings & Cautions, Lubrication & Installation Instructions

Mounted Bearings Warnings & Cautions

⚠ WARNING
Failure to observe safety precautions could cause personal injury or equipment damage.



⚠ WARNING
Do not operate without guards. Turn off power to install or service.



⚠ WARNING
High voltage and rotating parts may cause serious or fatal injury. Turn off power to install or service.

IMPORTANT SELECTION INFORMATION

The system of connected rotating parts must be free from critical speed, torsional, or other type vibration, regardless of how induced. The responsibility for this system analysis lies with the purchaser of the bearing unit.



SHIELD ALL ROTATING PARTS

For safety, purchaser or user must provide protective guards over all shaft extensions and any moving apparatus mounted on the unit. The user is responsible for checking and complying with all applicable safety codes in his area and providing suitable guards. Failure to do so may result in bodily injury and/or damage to equipment.



Wear protective clothing and eye shields when installing or maintaining bearing unit and machine.



A bearing unit cannot be used as an integral part of a machine superstructure which would impose additional loads on the unit other than those imposed by the torque being transmitted, or by any shaft mounted power transmitting device such as sprockets, pulleys, or couplings.



Make certain that all tools and other items are clear from rotating parts before starting machine. Stand clear, and start machine slowly to be sure all components are secure and operating properly.



For safe operation and to continue the bearing unit warranty, when installing or reinstalling a fastener for servicing purpose, or to accommodate the mounting of guards, shields or other light load imposing devices, or for mounting the bearing unit, it becomes the responsibility of the purchaser or user to properly determine the quality, grade of fastener, thread engagement, load carrying capacity, tightening torque, and the means of torque retention.

COUPLINGS — Flexible couplings are recommended because they minimize bearing wear caused by excessive misalignment. Follow coupling manufacturer's recommendations for installation and shielding.

SHEAVES AND SPROCKETS — When mounting sheaves or sprockets, the center of the load should be located as close to the bearing unit as possible. Excessive overhung loading could result in early failures of bearing or shaft. Refer to the general catalog or contact your local distributor for bearing load ratings. Follow manufacturer's recommendations for installation and shielding.



All Hub City bearing units are prelubricated with grease at the factory. Do not overgrease or undergrease, or injury to personnel, unit, or other equipment may result.



Grease should be added with greater frequency if unit is used in a severe environment such as dusty or humid or high or low temperatures.



Do not mix different grease types in the bearing unit.



If unit is used in the food or drug industry (including animal food) consult the petroleum supplier or HUB CITY for recommendations of lubricants which meet the specifications of FDA, USDA and/or other authoritative bodies having jurisdiction. Standard lubricants are not suitable for these applications or these industries.



Inspect shafts and components for paint, burrs, or other imperfections before installing components. Do not use excessive force or pounding to install components onto shafts, as this may cause damage to shafts or bearings.



Mounting bolts, coupling fasteners, and other power transmitting devices should be routinely checked to ensure that all parts of the unit are firmly anchored to provide proper operation (loose fasteners can cause alignment problems and excessive wear). Check end play in shafts. Noticeable movement might indicate service or parts replacement is necessary.

PREVENTATIVE MAINTENANCE — Keep shafts and zerk clean to prevent foreign particles from entering bearing unit. Inspect periodically for excessive grease leakage.



STORAGE OF HUB CITY BEARING UNITS:
A bearing unit does not have a definable shelf life. The main points of deterioration are rusting of non-painted surfaces and drying out of grease and the seal lips. Proper storage of bearing units in a cool dry place in a carton away from exposure to ultraviolet light should permit protection for approximately one year. For extended shutdown under these conditions, extra grease should be added to the bearing and distributed by rotating the bearing. Coat external shafts with a rust preventative oil or grease. After extended storage periods, a little fresh grease should be added prior to running.

Warnings & Cautions, Lubrication & Installation Instructions

Mounted Bearings Industrialine™ & Duraline™

INDUSTRIALINE™ and DURALINE™ MOUNTED BEARINGS LUBRICATION

General Note – These Lubrication instructions contain information for the IndustrialLine™ and DuraLine™ Mounted Bearings. For Lubrication Instructions specific to the CleanLine UltraPlus™, CleanLine Plus™, & CleanLine™ Mounted Bearings see the CleanLine™ Products page, S-11.



The proper lubrication of ball bearing units is critical in order to attain maximum bearing life expectancy. All Hub City bearing units are lubricated at the factory. Non-relube type bearings have no grease fitting and should not require additional lubricant. Relube type bearings are equipped with a lubrication fitting and should be periodically lubricated when used in wet or dirty applications. The amount and type of lubricant used will affect bearing life. Lack of lubricant can lead to premature surface fatigue failures of balls and races. Over lubrication can damage seals and result in premature failure from contamination due to the inability of damaged seals to keep foreign material out of the bearing. Under normal operating conditions, there is no need to relubricate bearings at all.

The following table is a general guide for relubrication. Experience will determine the best interval for each specific application.

OPERATING CONDITIONS	BEARING TEMPERATURES	GREASE INTERVAL
Clean	32° F to 120° F	6-12 Months
	120° F to 150° F	1-3 Months
	150° F to 200° F	1-4 Weeks
Dirty	32° F to 150° F	1-4 Weeks
	150° F to 200° F	Daily – 1 week
Moisture	32° F to 200° F	Daily – 1 week

Some Recommended Greases:

Texaco Multifak #2, Shell Alvania #2, Sun Prestige #41, Humble L100K #2, Sinclair Litholine Multi-Purpose, Mobil Mobilux #2, Conoco Super-Sta, Amoco Lithium MP, Chevron Dura-Lith EP #2 or equivalent NLGI #2, Multi-Purpose Lithium Grease.



When lubricating bearings add grease slowly. When the first sign of grease appears at the seals, the bearing will contain the correct amount of lubricant.

Bearings should not run in steady operation over 200° F and should not exceed 225° F for intermittent operation.

For unusual lubrication requirements or severe duty applications, contact Hub City for recommendations.

INDUSTRIALINE™ and DURALINE™ MOUNTED BEARINGS MOUNTING INSTRUCTIONS



Proper mounting of ball bearing units is critical to unit performance. Failure to follow accepted mounting practice may result in poor performance and short bearing life. Good engineering and design practice does not recommend the application of more than two bearings to support any shaft. Where more than two bearings are used to support the same shaft, it is possible to induce heavy bearing overloads. In these cases extreme care must be taken to line up bearings in both the vertical and horizontal planes. When the recommended two bearing support designs are used, alignment is not as critical. Hub City self aligning mounted bearing units will compensate for minor differences in mounting structure and gradual changes due to the settling of foundations. Misalignment up to 1.5° is allowable.



For the best results use turned and ground shafting, free of rough spots and burrs. If old shafting is used, mount bearing unit on a smooth unworn section, if possible. For ultimate life, snug fit on shaft should be used. Refer to tables below for Bearing Bore Tolerances and recommended Shaft Tolerances.

Shaft Tolerances

SHAFT DIA.	SHAFT TOLERANCE
1/2" - 1-15/16"	Plus .0000" to minus .0005"
2" - 3"	Plus .0000" to minus .0010"
3-3/16" - Up	Plus .0000" to minus .0015"

Bearing Bore Tolerances

BORE DIA.	BORE TOLERANCE
1/2" - 5/8"	Plus .0008" to minus .0000"
3/4" - 1-15/16"	Plus .0009" to minus .0000"
2" - 3"	Plus .0010" to minus .0000"
3-3/16" - Up	Plus .0012" to minus .0000"

Warnings & Cautions, Lubrication & Installation Instructions

Mounted Bearings Industrialine™ & Duraline™

Prior to mounting on shaft, clean mounting face, shaft and bearing bore. Coat shaft with a small amount of oil. Clean support surface and make sure it is flat.

INDUSTRIALINE™ and DURALINE™ MOUNTING PROCEDURES:

1. Slide bearing unit onto the shaft. For ECCENTRIC LOCK BEARINGS, if projecting side of the bearing is to be mounted toward the machine, put the locking collar on the shaft first. The eccentric locking collar should be opposing any thrust load.
2. Do not hammer the ends of the inner race. If it is necessary to apply force in mounting, use a soft metal bar or pipe against the inner race only. Tap the bearing unit into place.
3. It may be necessary to use shims to avoid shaft deflection and excessive misalignment. Bolt bearing housing securely to the support, by tightening capscrews alternately until tight.
- 4a. **SETSCREW LOCKING BEARINGS:** Align the setscrews on the two bearing units, and tighten setscrews alternately until tight.
- 4b. **ECCENTRIC LOCKING COLLAR BEARINGS:** Fit the eccentric locking collar on the inner race. Turn the collar in the direction of shaft rotation. Tighten the locking collar securely, using a spanner wrench, setscrew wrench, punch, or drift. Tighten the setscrew against the shaft. Refer to the setscrew tightening torque chart below.

SetScrew Tightening Torque

These torques are generally obtained when the set-screw stops turning and the hex socket wrench starts to spring.

SIZE	TORQUE IN-LBS.
10-32 NF	36
1/4-28 NF	87
5/16-24 NF	165
3/8-24 NF	290

CLEANLINE ULTRAPLUS™, CLEANLINE PLUS™ BEARINGS LUBRICATION



The proper lubrication of ball bearing units is critical in order to attain maximum bearing life expectancy. All Hub City CleanLine UltraPlus™, CleanLine Plus™, & CleanLine™ bearing units are lubricated at the factory with a grease that meets USDAH-1 standards for incidental contact with food. Non-relube type bearings have no grease fitting and should not require additional lubricant. Relube type bearings are equipped

with a lubrication fitting and should be periodically lubricated when used in wet or dirty applications. When relubricating CleanLine™ bearings, use only a grease which is approved for incidental contact with food. The amount and type of lubricant used will affect bearing life. Lack of lubricant can lead to premature surface fatigue failures of balls and races. Over lubrication can damage seals and result in premature failure from contamination due to the inability of damaged seals to keep foreign material out of the bearing.

The following table is a general guide for relubrication. Experience will determine the best interval for each specific application.

Recommended Grease or equivalent: Mobil Mobilgrease FM102, Chevron FM-2, Lubriplate FGL-2, SFL-2, Clearplex-2.



When lubricating bearings add grease slowly. When the first sign of grease appears at the seals, the bearing will contain the correct amount of lubricant.

Bearings should not run in steady operation over 200° F and should not exceed 225° F for intermittent operation.

For unusual lubrication requirements or severe duty applications, contact Hub City for recommendations.

OPERATING CONDITIONS	BEARING TEMPERATURES	GREASE INTERVAL
Clean	32° F to 120° F	6-12 Months
	120° F to 150° F	1-3 Months
	150° F to 200° F	1-4 Weeks
Dirty	32° F to 150° F	1-4 Weeks
	150° F to 200° F	Daily – 1 week
Moisture	32° F to 200° F	Daily – 1 week

CLEANLINE ULTRAPLUS™, CLEANLINE PLUS™ BEARINGS MOUNTING INSTRUCTIONS

Mounting Instructions for the CleanLine UltraPlus™, CleanLine Plus™, & CleanLine™ Mounted Bearings are the same as for the IndustrialLine™ and DuraLine™ Mounted Bearings. See IndustrialLine™ and DuraLine™ Mounted Bearings Mounting Instructions, pages S-10.

Warnings & Cautions, Lubrication & Installation Instructions

SPHERICAL ROLLER BEARING INSTALLATION



The following steps must be completed for proper installation of Hub City Spherical Roller Bearings:

1. Check the shaft to confirm it is clean, straight, undamaged and is within the recommended diameter tolerance shown in Table 1.
2. If using an open-end cover, slide open-end cover/seal combination into position on shaft.
3. Apply a thin oil film to shaft and bearing bore.
4. Slide bearing into position on shaft.
5. Tighten the bearing housing mounting bolts.
6. Tighten the locking collar set screws to the torque values shown in Table 2.
7. If using covers:
 - a. Clean and dry mating surface of cover and slightly roughen the mating surface of the cover with sandpaper or emery cloth.
 - b. Place a 1/8" - 1/4" bead of polyurethane adhesive sealant on mating surface of the cover.
 - c. Align the mounting holes of cover with the corresponding threaded holes in retaining nut and install mounting screws while making sure that the grease fitting on the cover remains accessible
 - d. Torque cover mounting screws to 53 in. lbs.
 - e. For maximum protection against contamination it is recommended that the covers be filled with grease. This can be done via zerk fitting or hand packed before installation.

Table 1

Recommended Shaft Tolerances

SHAFT SIZE	TOLERANCE
1-7/16" 1-1/2"	+0.000/-0.0015
1-11/16" 1-3/4"	+0.000/-0.0015
1-15/16" 2"	+0.000/-0.0015
2-3/16" 2-1/4"	+0.000/-0.0015
2-7/16" 2-1/2"	+0.000/-0.0015
2-11/16" 2-3/4" 2-15/16" 3"	+0.000/-0.002
3-7/16" 3-1/2"	+0.000/-0.003
3-15/16" 4"	+0.000/-0.003
4-7/16"	+0.000/-0.005
4-15/16"	+0.000/-0.005

Table 2

Recommended Set Screw Torque Values

SHAFT SIZE	SET SCREW SIZE	TORQUE (IN-LBS)
1-7/16" 1-1/2"	3/8"-24UNF	290
1-11/16" 1-3/4"	3/8"-24UNF	290
1-15/16" 2"	3/8"-24UNF	290
2-3/16" 2-1/4"	3/8"-24UNF	290
2-7/16" 2-1/2"	1/2"-20UNF	620
2-11/16" 2-3/4" 2-15/16" 3"	1/2"-20UNF	620
3-7/16" 3-1/2"	1/2"-20UNF	1325
3-15/16" 4"	5/8"-18UNF	1325
4-7/16"	5/8"-18UNF	1325
4-15/16"	5/8"-18UNF	1325

SPHERICAL ROLLER BEARING LUBRICATION



The proper lubrication of bearing units is critical in order to attain maximum bearing life expectancy. HUB CITY SPHERICAL ROLLER BEARINGS are factory filled with Ulti-Plex® Synthetic EP Grease, which is a multipurpose, high performance grease specially formulated for extreme pressure bearing applications operating under the most extreme high and low temperature conditions and for those difficult applications requiring extended lubrication intervals. This grease offers excellent thermal stability through temperatures ranging from -50° F to 400° F (-50° to 230° C). When dealing with temperatures above 300° F, consult the factory for optional grease recommendations. All Hub City bearing units are lubricated at the factory and should not require additional lubricant upon installation. Re-lubrication intervals noted in Table 3 are to be used as a general guide and depend on the type of application, speed, operating temperature and other environmental conditions. The amount and type of lubricant used will affect bearing life. Improper lubrication can lead to premature bearing failures.



For unusual lubrication requirements or severe duty applications, contact Hub City for recommendations.

Warnings & Cautions, Lubrication & Installation Instructions

SPHERICAL ROLLER BEARING INSTALLATION Cont.

Table 3

(Please note: The average manual grease gun will produce approximately one (1) ounce of grease per 33 strokes. Please check with the manufacturer of your grease delivery system for specific information.)

Recommended Re-Lubrication Intervals

SHAFT SIZE	INITIAL WT. (.OZ)	RELUBE WT. (.OZ)	RE-LUBRICATION INTERVAL (HOURS OF SERVICE BASED ON RPM AND AMBIENT TEMPERATURE (F))											
			100 RPM		250 RPM		500 RPM		1000 RPM		2000 RPM		3000 RPM	
			<160°	>160°	<160°	>160°	<160°	>160°	<160°	>160°	<160°	>160°	<160°	>160°
1-7/16" 1-1/2"	0.6	0.2	1600	800	1000	500	640	320	240	240	120	60	60	30
1-11/16" 1-3/4"	0.7	0.2	1600	800	1000	500	640	320	240	240	120	60	60	30
1-15/16" 2"	0.8	0.2	1600	1600	1000	500	640	320	240	240	120	60	60	30
2-3/16" 2-1/4"	1.0	0.3	1200	1200	800	400	440	220	160	160	100	50	60	30
2-7/16" 2-1/2"	1.4	0.4	1120	1120	720	360	360	180	120	120	80	40	40	20
2-11/16" 2-3/4" 2-15/16" 3"	2.7	0.7	1040	1040	680	340	340	170	100	100	60	30		
3-7/16" 3-1/2"	3.7	0.9	960	960	600	300	300	150	80	80	40	20		
3-15/16" 4"	6.5	1.6	840	840	520	260	240	120	60	60	20	16		
4-7/16"	7.4	1.9	680	680	440	220	200	100	60	60	20	16		
4-15/16"	10.6	2.7	560	560	360	180	160	80						

PROCEDURE TO CONVERT SPHERICAL ROLLER BEARING FROM FIXED TO FLOATING (NON-EXPANSION TO EXPANSION)

FLANGE BLOCK HOUSING

1. Make a reference mark on the housing and retaining nut.
2. Loosen set screws in housing that lock the retaining nut in place.
3. Loosen retaining nut by tapping with a hammer and punch, rotating retaining nut counter clockwise one complete revolution.
4. Tighten set screws in housing to lock retaining nut in place.

Please note: When converting a Spherical Roller bearing from fixed to floating, please ensure that the bearing is correctly oriented. A bearing that has been converted to expansion can only float in the direction of the loosened retaining nut.

PILLOW BLOCK HOUSING

1. Determine amount and direction of expansion needed. If uni-directional expansion is required, follow above directions on the nut that is on the side where expansion is desired
2. If bi-directional expansion is required follow the directions above on both nuts but the rotation should be one-half a revolution on each nut instead of one complete revolution.

PROCEDURE TO CONVERT SPHERICAL ROLLER BEARING FROM FLOATING TO FIXED (EXPANSION TO NON-EXPANSION)

FLANGE BLOCK HOUSING

1. Loosen set screws in housing that lock the retaining nut in place.
2. Tighten retaining nut by tapping with a hammer and punch, rotating retaining nut clockwise until tight. It is not possible to over-tighten the retaining nut.
3. Tighten set screw in housing to lock retaining nut in place.

PILLOW BLOCK HOUSING

1. Follow directions above on both nuts on either side of the housing.

Please Note: When converting from floating to fixed on a bearing that is mounted in the application, the set screws on the collars must be loosened to allow the insert to move in the housing and on the shaft.

Warnings & Cautions, Lubrication & Installation Instructions

HUBFLEX™ FLEXIBLE SHAFT COUPLINGS

CONGRATULATIONS...Your decision to purchase a HUBFLEX™ Flexible Shaft Coupling System from HUB CITY will provide you with trouble free service if the following installation instructions are adhered to.



IMPORTANT SELECTION INFORMATION

Read ALL instructions prior to operating coupler. Injury to personnel or reducer failure may be caused by improper installation, maintenance or operation.

Check to make certain application does not exceed the allowable load capacities published in the current catalog.

Written authorization from HUB CITY is required to operate or use couplings in man lift or people moving devices.

The system of connected rotating parts must be free from critical speed, torsional, or other type vibration, regardless of how induced. The responsibility for this system analysis lies with the purchaser of this product.

Buyer shall be solely responsible for determining the adequacy of the product for any and all uses to which Buyer shall apply the product. The application by Buyer shall not be subject to any implied warranty of fitness for a particular purpose.

INSTALLATION



Wear protective clothing and eye shields when installing or maintaining unit and machine.



Make certain that the power supply is disconnected before attempting to service or remove any components. Lock out the power supply and tag it to prevent unexpected application of power.



SHIELD ALL ROTATING PARTS

For safety, purchaser or user must provide protective guards over all shaft extensions and any moving apparatus mounted on the unit. The user is responsible for checking and complying with all applicable safety codes in his area and providing suitable guards. Failure to do so may result in bodily injury and/or damage to equipment.



Couplings are not to be considered fail-safe or self-locking devices. If these features are required, a properly sized, independent holding device should be utilized.



Any brakes that are used in conjunction with a coupling must be sized or positioned in such a way so as to not subject the reducer to loads beyond the catalog rating.

Please follow the step by step installation instructions to properly install HUBFLEX™ Couplings:

Required components:

- 2 Hubs
- 1 Insert
- 1 Cover with hardware*

*Identify what style cover you are using as this will determine the proper installation procedure.

There are two types of covers (Figure 1):

1. Standard Cover (SD): for coupling sizes HF10 through HF40 a standard snap ring secures cover in place.
2. Extreme Duty Horizontal Split Cover (XH): It is a free floating cover that encapsulates the insert and the shoulder of both hubs. Each cover assembly comes with four socket head cap screws to secure the two halves together.

Warnings & Cautions, Lubrication & Installation Instructions

HUBFLEX™ FLEXIBLE SHAFT COUPLINGS

Figure 1. HUBFLEX™ covers and types, and included hardware.

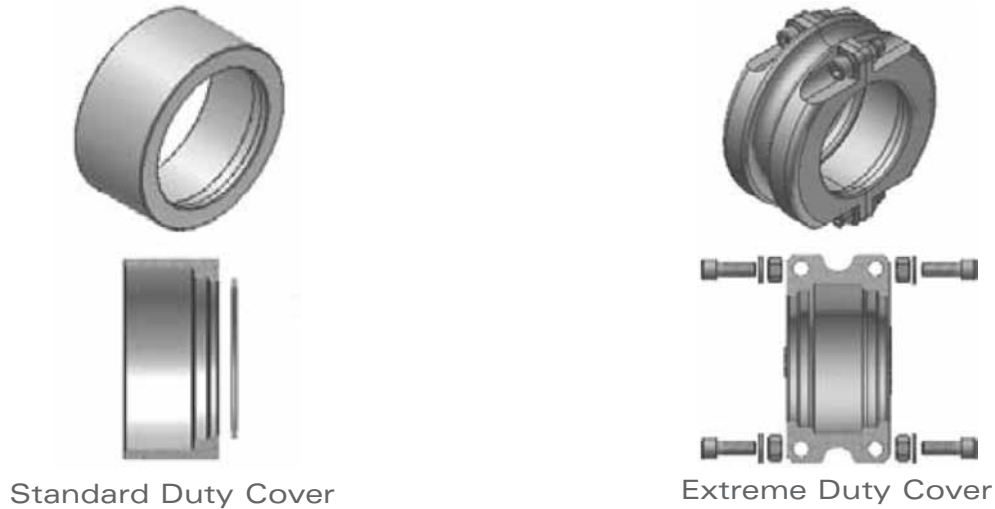

Installation Instructions:

1. Confirm bore sizes of each coupling half and the corresponding shaft diameter to ensure that you have the proper bore size.
2. Ensure that the shafts are clean and free from burrs.
3. Verify cover style:
 - When using a Standard Duty Cover (SD), it should be located on the driven shaft. If space is limited, then it can be mounted on the drive shaft. Slide snap ring first, then Standard Duty Cover (SD) with larger opening facing the shaft separation.
 - When using an Extreme Duty Horizontal Split Cover (XD), proceed to step 4.
4. Installing the first hub: It should be mounted so that the end of the shaft is flush with surface "A" as shown in Figure 2. It is acceptable for the shaft to extend past "A" as long as it is not past the teeth shown as "B".
5. Please note: Standard hubs are supplied with a clearance fit and should slide onto the shaft without excessive force. If the hubs have been ordered with interference fit (shrink fit), then heat the coupling halves to approximately 572 degrees Fahrenheit (300 degrees Celsius) before installing on shafts.
6. With the insert in place, install the second hub. This will automatically set the hubs at the minimum hub gap (E min) dimension to ensure proper clearance. Please see Table 1 for specific E min and E max dimensions.
7. Now ensure both hubs are securely tightened to the shafts.
8. Check coupling for misalignment and align as necessary. Please refer to Table 2 for misalignment tolerances.
9. Installation of cover:
 - Standard Duty Cover (SD): slide the cover over hub and insert until the step in the cover contacts the shoulder of the hub. Use snap ring pliers to slide snap ring over hub and into snap ring groove in hub to hold the cover in place.
 - Extreme Duty Horizontal Split Cover (XH): place each half over the insert and shoulder on hubs. Secure the two housing halves together by using the included hardware set supplied.

Maximum RPM and Balance:

The HUBFLEX™ coupling inherently has good dynamic balance due to our manufacturing process. In high speed applications, it is important that the key used to attach hubs to shaft is the same length as the hub. The set screws should also be changed to full length to fill the hole. Please refer to Table 1 for maximum RPM ratings.

Warnings & Cautions, Lubrication & Installation Instructions

HUBFLEX™ FLEXIBLE SHAFT COUPLINGS

Figure 2. HUBFLEX™ shaft-to-hub alignment.

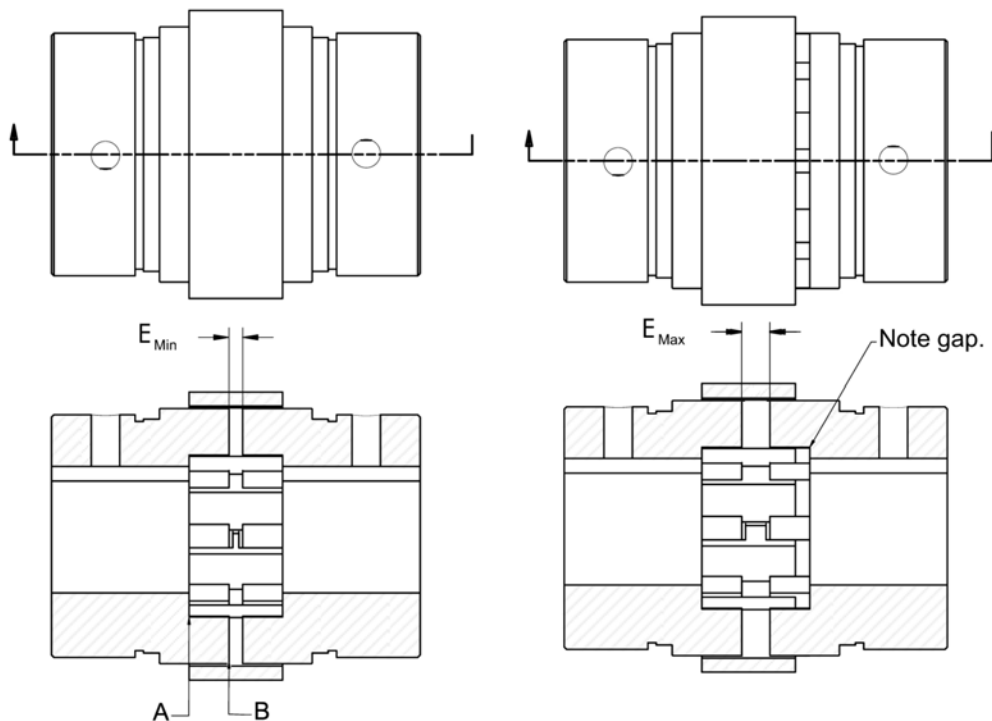

Table 1. EMIN and EMAX Dimensions.

COUPLING SERIES	MAXIMUM RPM	STANDARD DUTY EMIN	STANDARD DUTY EMAX	EXTREME DUTY EMIN	EXTREME DUTY EMAX
HF10	4000*	0.062	0.092	—	—
HF20	4000*	0.036	0.110	0.036	0.220
HF30	4000*	0.080	0.205	0.080	0.160
HF40	4000*	0.035	0.208	0.035	0.160
Additional Sizes Available Soon:					
HF50	4000*	0.140	0.290	0.140	0.370
HF60	4000*	0.188	0.208	0.188	0.368
HF70	3800	0.100	0.230	0.100	0.318
HF80	3400	0.125	0.250	—	—

*For applications over 4000 RPM, consult factory

Warnings & Cautions, Lubrication & Installation Instructions

HUBFLEX™ FLEXIBLE SHAFT COUPLINGS

Table 2. Misalignment tolerances.

HubFlex™ Couplings Misalignment Tolerances

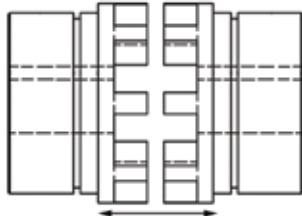
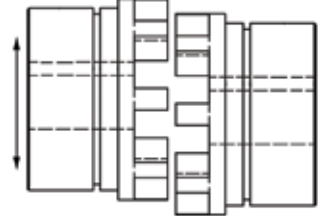
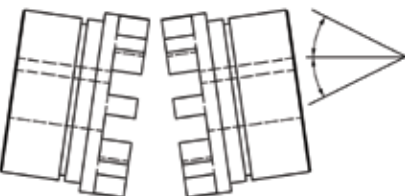
Coupling Series	Axial Misalignment Tolerance (in.)	Radial Misalignment Tolerance (in.)	Angular Misalignment Tolerance
HF10	0.078	0.020	2°
HF20	0.116	0.039	2°
HF30	0.116	0.039	2°
HF40	0.116	0.039	2°
Additional Sizes Available Soon:			
HF50	0.156	0.058	2°
HF60	0.175	0.058	1.3°
HF70	0.234	0.058	1.3°
HF80	0.234	0.058	1°
HF90	0.234	0.058	1°
HF100	0.312	0.058	1°
HF110	0.312	0.078	1°
HF120	0.312	0.078	1°
			



Make certain that all tools and other items are clear from rotating parts before starting machine. Stand clear, and start machine slowly to be sure all components are secure and operating properly.

Important Information:

In the event of the resale of any of the goods, in whatever form, Resellers/Buyers will include the following language in a conspicuous place and in a conspicuous manner in a written agreement covering such sale:

The manufacturer makes no warranties or representations, express or implied, by operation of law or otherwise, as to the merchantability or fitness for a particular purpose of the goods sold hereunder. Buyer acknowledges that it alone has determined that the goods purchased hereunder will suitably meet the requirements of their intended use. In no event will the manufacturer be liable for consequential, incidental or other damages.

Resellers/Buyers agree to also include this entire document including the warnings and cautions above in a conspicuous place and in a conspicuous manner in writing to instruct users on the safe usage of the product.

For assistance, contact or write your local Industrial Power Transmission Distributor, or the factory office.

Terms and Conditions Of Sale

QUOTATIONS ARE MADE AND ORDERS ARE ACCEPTED BY SELLER SUBJECT ONLY TO THESE TERMS AND CONDITIONS:

1. **AGREEMENT AND MODIFICATION OF SALES TERMS.** The agreement between Seller and Buyer ("Sales Contract") is with respect to the sale of goods described on the other side hereof (the "goods"). Any Terms and Conditions contained in any purchase order or other form of communication from Seller's customers which are additional to or different from these Terms and Conditions shall be deemed rejected by Seller unless expressly accepted in writing by Seller.

2. **ACCEPTANCE OF ORDERS.** Acceptance by Seller of Buyer's purchase order(s) is expressly conditioned upon Buyer's assent to these Terms and Conditions. Buyer will be deemed to have assented to such Terms and Conditions unless Seller receives written notice of any objections within 10 days after Buyer's receipt of this form or in all events prior to any delivery or other performance by Seller of Buyer's order if less than 10 days.

3. **QUOTATIONS.** Quotations by Seller shall be deemed to be offers by Seller to sell the goods described therein subject to these Terms and Conditions, and acceptance of such offers is expressly limited to acceptance by Buyer of all of these Terms and Conditions within 30 days from the date of the quotation or as specified. Purchase orders submitted by Buyer for the goods quoted by Seller shall be subject to and will be deemed to constitute acceptance of these Terms and Conditions. All purchase orders will be subject to approval by Seller.

4. **TERMINATION OR MODIFICATION.** The Sales Contract may be modified or terminated only upon Seller's express written consent, which consent will at all times be conditioned on Buyer's agreement to pay Seller's modification or termination charge including, but not limited to expenses and costs plus a reasonable profit, except that any goods completed on or before Seller's acceptance of termination shall be accepted and paid in full by Buyer.

5. **PRICES AND TERMS.** Fulfillment of Buyer's order is contingent upon the availability of materials. The price of the goods sold pursuant to the Sales Contract shall be based upon Seller's prices in effect at the time of shipment and any acceptance of the order will be on the basis of the freight rates now in effect. In the event of an increase or decrease in the applicable freight charges before the material is shipped, such changes in freight charges will be for the account of Buyer. Price advances, discounts, extras and terms and conditions are subject to changes without notice. Unless otherwise provided on the front side hereof, price is F.O.B. Seller's point of shipment, and terms of payment shall be net 30 days from date of invoice. Seller may assess a delinquency charge of 1-1/2 percent per month on invoices not paid within stated payment terms. Seller may require full or partial payment or payment guarantees in advance of shipment whenever, in its opinion, the financial condition of Buyer so warrants. In addition, Seller may, at any time, suspend performance of any order or require payment in cash, security or other adequate assurance satisfactory to Seller when, in Seller's opinion, the financial condition of Buyer warrants such action.

6. **TAXES.** Prices do not include sales, use or other similar federal, state or local taxes. Buyer shall pay to Seller, in addition to the price of the goods, all applicable taxes which may be invoiced separately at a later date.

7. **DESIGN; EXTRA WORK; BUYER'S MATERIAL.** (a) If any order accepted by Seller contemplates the preparation of special designs by Seller, Buyer issuing such order will have a responsible representative specifically approve all designs prepared by Seller.

(b) If Buyer requests extra work not included in the quotation or original order, Buyer will pay for the extra work at reasonable rates as determined by Seller.

(c) In the event spoilage/damage occurs on orders where Buyer furnishes the material, Seller shall not be liable for replacement of or damage to such material.

8. **RISK OF LOSS, TITLE, SECURITY INTEREST.** Delivery shall occur, and risk of loss shall pass to Buyer, upon delivery of the material to a carrier at the F.O.B. point of shipment. Transportation shall be at Buyer's sole risk and expense, and any claims for losses or damage in transit shall be against the carrier only. However, Seller retains title to all products until paid for in full in cash and Buyer agrees to perform all acts necessary to provide a fully perfected security interest in the goods in favor of Seller. Seller may, at Seller's option, repossess the same, upon Buyer's default in payment hereunder, and charge Buyer with any deficiency.

9. **DELIVERIES AND QUANTITIES.** (a) Delivery dates are not guaranteed but are estimated on the basis of immediate receipt by Seller of all information to be furnished by Buyer and the absence of delay, direct or indirect, resulting from or contributed to by circumstances beyond Seller's reasonable control. If the goods are non-catalog goods, Seller may ship overages or underages to the extent of 10 percent of quantity ordered, and Buyer shall pay for such quantity based upon the unit price of the goods. Seller shall not be required to maintain closer control of

quantity, unless specifically agreed to by Seller in writing. Quantities of all items may be determined by weight. Any claims for shortage must be within 10 days from the date of receipt of the goods by Buyer, and in every case the weights found in any particular shipment, including tare, must be given and Seller advised as to the method used by Buyer in computing the count of parts.

(b) In the event that Buyer is unable to accept delivery of the goods at time of shipment, Seller shall invoice Buyer for the full purchase price as if shipment had been made and: (i) if Seller is able to store such goods in its own facilities, Buyer will pay Seller the reasonable handling and storage charges for the period of such storage, and (ii) if Seller is unable to store such goods at its own facility, Seller reserves the right to arrange handling and storage in a suitable bonded warehouse for the Buyer at Buyer's expense. In cases where handling and storage become necessary, it shall be Buyer's responsibility to notify Seller when shipment is to be made. Seller will make necessary arrangements for shipment at Buyer's expense.

10. **RETURNED GOODS.** Goods may not be returned. However, if Seller consents in writing or upon verbal authorization to the return of goods for any reason, transportation charges must be prepaid by Buyer, who also shall assume all risk of loss of such returned goods until actual receipt by Seller.

11. **INSPECTION, ACCEPTANCE.** Buyer shall inspect the goods immediately upon the receipt thereof. All claims by Buyer (including claims for shortages), except only those provided for under the WARRANTY AND LIMITATIONS OF LIABILITY and PATENTS clauses below, must be asserted in writing by Buyer within a 10 day period or they are waived. If this contract involves partial performances, all such claims must be asserted within a 10 day period for each partial performance. Rejection may be only for defects substantially impairing the value of products or work. Buyer's remedy for lesser defects shall be those provided for under the Warranty and Liability clauses. THERE SHALL BE NO REVOCATION OF ACCEPTANCE. If Buyer wrongfully rejects, revokes or delays acceptance of items or work tendered under this contract, or fails to make a payment due on or before delivery, or repudiates this contract, Seller shall, at its option, have a right to recover as damages, either the price as stated herein (upon recovery of the price, the items involved shall become the property of the Buyer) or the profit (including reasonable overhead) which the Seller would make from performance together with incidental damages and reasonable cost.

12. **WARRANTIES AND LIMITATIONS OF LIABILITY.** (a) Seller warrants to Buyer that the goods will conform to the following warranty: The goods will be commercially free from defects in material and workmanship under normal use for a period of 1 year from the date of shipment of the goods by Seller and will conform at the date of shipment to applicable specifications, drawings and blueprints, except for departures therefrom with written approval of Buyer; provided that work performed by Seller upon blanks and other materials furnished by Buyer is excluded from this warranty. Seller shall have no liability to Buyer for cost of blanks furnished by Buyer which are damaged or spoiled during heat treat or machining operations;

(b) In the case of drives, gears and reducers manufactured by Seller, Seller warrants only that such products, when shipped, shall be capable of delivering the service rating as indicated in Seller's written documents, including quotations and catalogs or as noted on such products, providing such equipment is properly installed and maintained, correctly lubricated, operating under normal conditions with competent supervision, and within the load limits for that it was sold, and provided further that the equipment is free from critical speed, torsional or other type vibration, no matter how induced;

(c) If any model or sample was provided to the Buyer, it was used merely to illustrate the general type and quality of goods and not to warrant that goods shipped would be of that type or quality;

(d) UNLESS AUTHORIZED IN WRITING BY A CORPORATE OFFICER OR VICE PRESIDENT, NO AGENT, EMPLOYEE OR REPRESENTATIVE OF SELLER HAS ANY AUTHORITY TO BIND SELLER TO ANY AFFIRMATION, REPRESENTATION OR WARRANTY CONCERNING THE GOODS SOLD UNDER THE SALES CONTRACT AND ANY SUCH AFFIRMATION, REPRESENTATION OR WARRANTY HAS NOT FORMED A PART OF THE BASIS OF THE BARGAIN AND SHALL BE UNENFORCEABLE;

(e) Seller's sole obligation under the foregoing warranties is limited to either, at Seller's option, replacing or repairing defective goods (or defective parts thereof). This warranty does not cover the cost of installation of the new or repaired goods or parts. Replacement goods or parts are warranted for the remainder of the warranty period applicable to the goods originally supplied by Seller. All claims for allegedly defective goods must be made within 10 days after Buyer learns of such alleged defects. All claims not made in writing and received by Seller within such 10 day period shall be deemed waived. Buyer shall return a sample of the alleged defective part for Seller's inspection, and no other goods shall be returned to Seller without Seller's written consent. This warranty shall not extend to goods subjected

Terms and Conditions Of Sale

to misuse, abuse, neglect, accident or improper installation or maintenance, incorrect lubrication, or goods which have been altered or repaired by anyone other than Seller or its authorized representative;

(f) THE FOREGOING WARRANTIES ARE EXCLUSIVE AND IN LIEU OF ALL OTHER WARRANTIES OF MERCHANTABILITY, FITNESS FOR A PARTICULAR PURPOSE AND/OR ANY OTHER TYPE, WHETHER EXPRESS OR IMPLIED;

(g) Products not manufactured and work not performed by Seller are warranted only to the extent and in the manner that the same are warranted to Seller by Seller's vendors, and then only to the extent that Seller is reasonably able to enforce such warranty. In enforcing such warranty, it is understood Seller shall have no obligation to initiate litigation unless Buyer undertakes to pay all costs and expenses therefor, including but not limited to Attorney's fees, and indemnifies Seller against any liability to Seller's vendors arising out of such litigation;

(h) THE FOREGOING IS SELLER'S ONLY OBLIGATION AND BUYER'S EXCLUSIVE REMEDY FOR BREACH OF WARRANTY. BUYER'S FAILURE TO SUBMIT A CLAIM AS PROVIDED ABOVE SHALL SPECIFICALLY WAIVE ALL CLAIMS FOR DAMAGES OR OTHER RELIEF INCLUDING BUT NOT LIMITED TO CLAIMS BASED ON LATENT DEFECTS. IN NO EVENT SHALL BUYER BE ENTITLED TO INCIDENTAL, CONSEQUENTIAL, CONTINGENT, OR SPECIAL DAMAGES, NOR SHALL SELLER'S LIABILITY EXCEED THE PURCHASE PRICE OF THE GOODS. EVEN IF THE REPAIR OR REPLACEMENT REMEDY SHALL BE DEEMED TO HAVE FAILED OF ITS ESSENTIAL PURPOSE UNDER SECTION 2-719 OF THE UNIFORM COMMERCIAL CODE, SELLER SHALL HAVE NO LIABILITY TO BUYER FOR CONSEQUENTIAL OR INCIDENTAL DAMAGES, SUCH AS LOST PROFITS, LOST REVENUE, DAMAGE TO OTHER EQUIPMENT OR LIABILITY OR INJURY TO A THIRD PARTY. ANY ACTION ARISING HEREUNDER OR RELATED HERETO MUST BE COMMENCED WITHIN ONE (1) YEAR AFTER THE CAUSE OF ACTION OCCURS OR IT SHALL BE BARRED, NOTWITHSTANDING ANY STATUTORY PERIOD OF LIMITATIONS TO THE CONTRARY; and

(i) In the event of the resale of any of the goods, in whatever form, Buyer will include the following language in a conspicuous place and in a conspicuous manner in a written agreement covering such resale: "THE MANUFACTURER MAKES NO WARRANTIES OR REPRESENTATIONS, EXPRESS OR IMPLIED, BY OPERATION OF LAW OR OTHERWISE, AS TO THE MERCHANTABILITY OR FITNESS FOR A PARTICULAR PURPOSE OF THE GOODS SOLD HEREUNDER. BUYER ACKNOWLEDGES THAT IT ALONE HAS DETERMINED THAT THE GOODS PURCHASED HEREUNDER WILL SUITABLY MEET THE REQUIREMENTS OF THEIR INTENDED USE. IN NO EVENT WILL MANUFACTURER BE LIABLE FOR CONSEQUENTIAL, INCIDENTAL OR OTHER DAMAGES."

(j) Nuclear Use Disclaimer - Equipment sold by Seller is not intended for use in connection with any nuclear facility or activity. If so used, Seller disclaims all liability for any nuclear damage, injury or contamination, and Buyer shall indemnify and hold Seller, its officers, agents, employees, successors, assigns and customers harmless from and against any and all losses, damages or expenses of whatever form or nature (including attorneys' fees and other costs of defending any action) which they or any of them may sustain or incur, whether as a result of breach of contract, warranty, tort (including negligence) or otherwise, by reason of such use.

13. REMEDIES AND LIMITATIONS OF LIABILITY. In the event Buyer claims Seller has breached any of its obligations under the Sales Contract, whether of warranty or otherwise, Seller may request the return of goods and tender to Buyer, at Seller's option, a replacement shipment of goods. If Seller so requests the return of the goods, the goods will be redelivered to Seller in accordance with Seller's instructions and at Buyer's expense. Except as herein provided, Seller shall have no further obligation under the Sales Contract. The remedies contained in this paragraph and paragraph 12 hereof shall constitute the sole recourse of Buyer against Seller for breach of any of Seller's obligations under the Sales Contract, whether warranty or otherwise.

14. TECHNICAL ADVICE. Any technical advice furnished or recommendation made by Seller or any representative of Seller concerning any use or application of any of the goods is believed to be reliable, but SELLER MAKES NO WARRANTY, EXPRESSED OR IMPLIED, ON RESULTS TO BE OBTAINED. BUYER ASSUMES ALL RESPONSIBILITY FOR LOSS OR DAMAGE RESULTING FROM THE HANDLING OR USE OF ANY OF THE GOODS.

15. FORCE MAJEURE. Seller shall not be liable for failure to perform its obligations under the Sales Contract in whole or in part caused by the occurrence of any contingencies beyond the reasonable control either of Seller or of suppliers of Seller. If any such contingency occurs, Seller may allocate goods and deliveries among Seller's customers.

16. ASSIGNMENT AND DELEGATION. No right or interest in the Sales Contract shall be assigned by Buyer without Seller's prior written consent, and no delegation of any obligation owed, or to the performance of any obligation by Buyer shall be made without Seller's prior written consent. Any attempt at assignment or delegation shall be wholly void and totally ineffective for all purposes unless made in conformity with this paragraph.

17. PATTERNS AND TOOLING. Unless otherwise agreed to in writing with Buyer, Seller shall retain title to and possession of all special tooling, patterns and dies whether paid for by Buyer or not, but such special tooling, patterns and dies that are specifically paid for by Buyer will be held by Seller exclusively for the manufacture of Buyer's goods for not more than 2 years after the date of Buyer's last order requiring their use. Seller will exercise reasonable care in handling and storing any tooling, patterns or dies specifically paid for by Buyer, but Seller shall not be liable for damage or loss thereof.

18. PATENTS. SELLER MAKES NO REPRESENTATION OR WARRANTY WITH RESPECT TO THE PATENTABILITY OF THE GOODS OR THAT ANY OF THE GOODS WILL BE FREE FROM CLAIMS OF INFRINGEMENT. Buyer agrees to indemnify and defend Seller in any such suit, action or proceeding for any claim resulting from actual or alleged infringement of any domestic or foreign letters patent for (i) any feature, construction or design incorporated at Buyer's request in any goods or to adapt such goods to the particular use of Buyer or Buyer's customers or (ii) any additions, changes or adaptations made by Buyer or Buyer's customers after delivery of the goods.

19. CONFIDENTIAL INFORMATION. All drawings, diagrams, specifications, technical data and other materials furnished by Seller and identified by Seller as confidential are and shall remain the exclusive property of Seller and shall be returned to Seller upon request. Buyer agrees to treat such information and material as confidential and not to reproduce or disclose such information or materials without Seller's prior written consent. This paragraph does not apply to any information already known to and readily accessible in the trade or which may become so through no fault of Buyer.

20. CHANGES. Seller may, at any time, without notice, make changes (whether in design, material, improvements or otherwise) in any catalog goods, and may discontinue the manufacture of any catalog goods, all in its sole discretion, without incurring any obligations of any kind as a result thereof, whether for failure to fill an order of Buyer or otherwise.

21. INSTALLATION. Installation of the goods shall be by Buyer unless otherwise specifically stated in the Sales Contract.

22. SEVERABILITY. If any term or provision contained in the Sales Contract is declared or held invalid by a court of competent jurisdiction, such declaration or holding shall not affect the validity of any other term, clause or provision contained herein.

23. GOVERNING LAW AND LIMITATION. (a) The formation and performance of the Sales Contract shall be deemed to have been made and governed by the Uniform Commercial Code as adopted in the state of Seller's principal place of business;

(b) Buyer hereby agrees to the jurisdiction of any state or federal court located in the county of Seller's principal place of business. Buyer waives any objection based on forum non conveniens and any objection to venue of any action instituted hereunder, and consents to the granting of such legal or equitable relief as is deemed appropriate by a court of competent jurisdiction. The rights and obligations of Seller and Buyer shall not be governed by the provisions of the United Nations Convention on Contracts for the International Sale of Goods; and

(c) Seller represents that the goods will be produced in compliance with the Fair Labor Standards Act of 1938, as amended.

(d) BUYER AGREES TO PAY ALL OF SELLER'S COSTS AND EXPENSES OF COLLECTION AND LITIGATION, INCLUDING BUT NOT LIMITED TO ATTORNEYS' FEES AND COSTS.

Revised December 2008

Model Index

MODEL	RATINGS	DIMENSIONS	MODEL	RATINGS	DIMENSIONS	MODEL	RATINGS	DIMENSIONS
0331-xxxxx	SEE PAGE R20		FB260	M14	M25	PB251STW	O10	O3
0332-xxxxx	SEE PAGE R20		FB260CTW	O10-O11	O8	PB251UR	N3	N7
0334-xxxxx	SEE PAGE R20		FB260DRW	N3	N14	PB251W	M14	M19
0339-xxxxx	SEE PAGE R20		FB260HW	M14	M26	PB281WAH	M14	M8
1TWS200	NA	M34	FB260STW	O10	O4	PB350	M37	M38
3T200	NA	M33	FB260UR	N3	N13	PB350DRW	N3	N24
3TWS200	NA	M34	FB280HWAH	M14	M8	PB350H	M37	M39
6T200	NA	M33	FB290HWAH	M14	M9	PT21107	G12	G14
6T210	NA	M32	FB350	M37	M38	PT22115	G12	G14
6TWS200	NA	M34	FB350DRW	N3	N24	PT23203	G12	G14
9T200	NA	M33	FB350H	M37	M39	PT24207	G12	G14
9T210	NA	M32	FC250	M14	M27	PT25215	G12	G14
9TWS200	NA	M34	FC250URW	N3	N17	PT26307	G13	G14
12T200	NA	M33	FC350	M37	M40	PT27315	G13	G14
12T210	NA	M32	FC350URW	N3	N25	PT28407	G13	G14
12TWS200	NA	M34	FR250STW	O10	O5	PT29415	G13	G14
18T200	NA	M33	FR250URW	N3	N17	PT210507	G13	G14
18T210	NA	M32	FR250W	M14	M27	TPB220	M14	M21
18TWS200	NA	M34	HF10	SEE SECTION Q		TPB220UR	N3	N9
B220	M14	M35	HF20	SEE SECTION Q		TPB220URW	N3	N9
B220R	N3	N22	HF30	SEE SECTION Q		TPB220W	M14	M21
B220RW	N3	N23	HF40	SEE SECTION Q		TPB250	M14	M22
B250	M14	M35	HF50	SEE SECTION Q		TPB250CTW	O10-O11	O7
B250R	N3	N22	HF60	SEE SECTION Q		TPB250URW	N3	N10
B250RW	N3	N23	HF70	SEE SECTION Q		TPB250STW	O10	O3
B250TW	O10	O9	HF80	SEE SECTION Q		TPB250UR	N3	N10
B280WAH	M14	M9	KFB	P7	P12	TPB250W	M14	M22
B350	M37	M41	KFBE	P7	P15	TU220	M14	M28
B350RW	N3	N27	KPB	P7	P10	TU220UR	N3	N18
FB110	M14	M11	KPBE	P7	P13	TU220URW	N3	N19
FB110UR	N3	N11	PB120	M14	M10	TU220W	M14	M29
FB120	M14	M12	PB120UR	N3	N4	TU250	M14	M28
FB120UR	N3	N12	PB150	M14	M10	TU250STW	O10	O5
FB130	M14	M12	PB150UR	N3	N4	TU250UR	N3	N18
FB130UR	N3	N11	PB220	M14	M15	TU250URW	N3	N19
FB150	M14	M13	PB220DRW	N3	N6	TU250W	M14	M29
FB150UR	N3	N12	PB220HW	M14	M17	TU350	M37	M40
FB160	M14	M13	PB220UR	N3	N5	TU350URW	N3	N26
FB160UR	N3	N11	PB220W	M14	M16	WSTU220	M14	M30
FB220	M14	M23	PB221	M14	M15	WSTU220UR	N3	N20
FB220DRW	N3	N16	PB221DRW	N14	N6	WSTU220URW	N3	N21
FB220HW	M14	M24	PB221HW	M14	M17	WSTU220W	M14	M31
FB220UR	N3	N15	PB221UR	N3	N5	WSTU250	M14	M30
FB230	M14	M23	PB221W	M14	M16	WSTU250STW	O10	O6
FB230DRW	N3	N14	PB250	M14	M18	WSTU250UR	N3	N20
FB230UR	N3	N13	PB250DRW	N3	N8	WSTU250URW	N3	N21
FB230HW	M14	M24	PB250HW	M14	M20	WSTU250W	M14	M31
FB250	M14	M25	PB250UR	N3	N7	WSTU350	M37	M41
FB250CTW	O10-O11	O8	PB250W	M14	M19	WSTU350URW	N3	N26
FB250DRW	N3	N16	PB251	M14	M18	YW220	M14	M36
FB250HW	M14	M26	PB251CTW	O10-O11	O7	YW250	M14	M36
FB250STW	O10	O4	PB251DRW	N3	N8			
FB250UR	N3	N15	PB251HW	M14	M20			

Application Oriented

Your application may be entirely different than the ones pictured on this page, but our customers have come from a multitude of industries over the past century we've been in business. Our products are used in material handling, packaging, medical equipment, food processing, transportation, construction, aerospace and marine applications ...and it doesn't stop here. Over 50% of what we manufacture is either modified standard products or completely customized.

We know time is valuable, that's why you can count on HUB CITY for support, services and solutions to simplify your installation. Select from a complete line of standard or custom design products.



Standard, modified & custom units are built for countless applications.

Solutions Driven

Does your application require CAD drawings? How about a configurator to aid your gear drive selection? Log on to www.hubcityinc.com where you may access our catalog tool for configuring and selecting a gear drive or mounted bearing. Then download our 2D or 3D CAD drawings, browse through the standard and custom product overviews, read what's new at the "HUB," and order product literature. Download all of our product literature in an easy to use PDF format. If a custom gear drive is what your are looking for, there are several examples of HUB CITY's custom capabilities featured here.

Do you need to speak to a HUB CITY field salesperson? Contact information is located on the site, as well as a HUB CITY Authorized Distributor directory searchable by zip code.

www.hubcityinc.com

EMAIL: hubsales@regalbeloit.com • www.hubcityinc.com

MEDICAL

FOOD PROCESSING

CONSTRUCTION

PACKAGING

TRANSPORTATION

AEROSPACE

AGRICULTURE

MATERIAL HANDLING

RECREATION

AND MANY MORE...

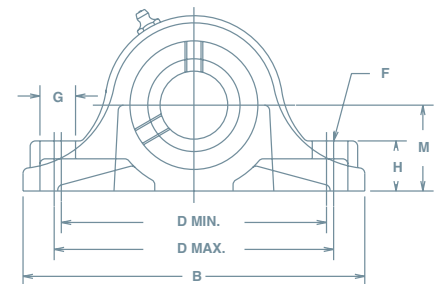

CUSTOMER SERVICE

CATALOG TOOLS

CONFIGURATOR

CAD DRAWINGS

CUSTOM PRODUCTS

STANDARD PRODUCTS

LOCATE DISTRIBUTORS

FIELD SALES OFFICES

Support • Service

And Solutions



Located to Serve You!

24-Hour assembly and shipment, and on-the-shelf availability of our most sought after products

Hub City Headquarters

2914 Industrial Avenue
Aberdeen, SD 57402
(605) 225-0360
(800) 482-2489

Hub City Florida

4725 Lakeland Commerce Pkwy., Suite 6
Lakeland, FL 33805
(863) 665-9374

Hub City West

11034 Forest Place
Santa Fe Springs, CA 90670
(714) 776-1992
(800) 551-6661

Hub City Southwest

3251 Royalty Row
Irving, TX 75062
(972) 721-0080
(800) 494-1918

Hub City Midwest

9899 E. Cty Rd 200 South
Avon, IN 46123
(317) 837-1150
(800) 253-4281

Hub City Northeast

6520 Stonegate Drive
Allentown, PA 18106
(610) 391-9298
(800) 452-1117

Hub City Southeast

135 Cecil Court
Fayetteville, GA 30214
(770) 461-8334
(800) 777-7159

Hub City East

1011 Van Buren Avenue
Indian Trail, NC 28079
(704) 847-9131

Hub City Canada

80 Hale Road Unit #1
Brampton, Ontario L6W 3N9
(905) 455-6969
(888) 661-1889



2914 Industrial Avenue
Aberdeen, SD 57402 USA
PH: 605-225-0360
FAX: 605-225-0567
Email: hubsales@regalbeloit.com

www.hubcityinc.com



Made in U.S.A.



A Regal Brand

REGAL

www.regalbeloit.com